

National Aeronautics and  
Space Administration



International VLBI Service for  
Geodesy and Astrometry

---

# Annual Report 2009

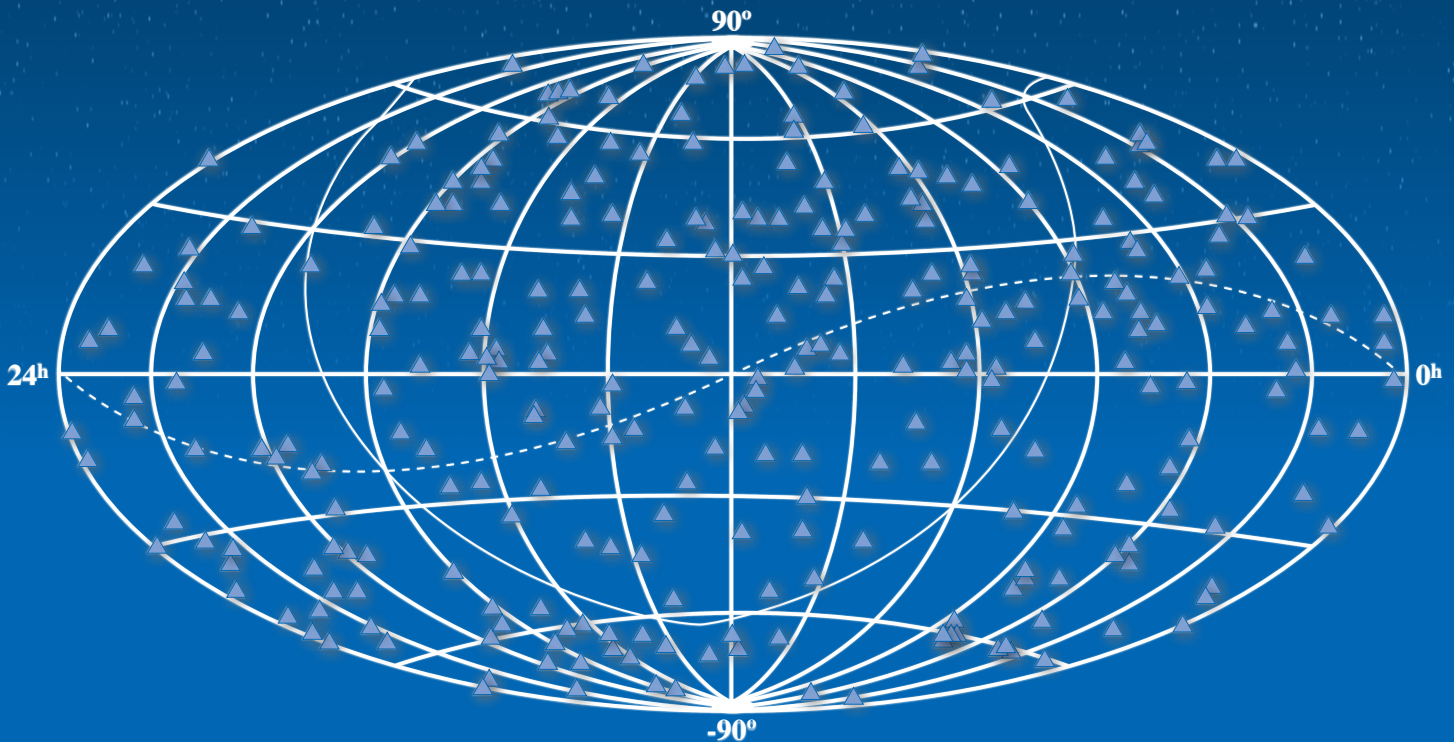

---

Edited by  
D. Behrend and K.D. Baver

NASA/TP-2010-215860

IVS Coordinating Center  
August 2010

[www.nasa.gov](http://www.nasa.gov)

## The NASA STI Program Office ... in Profile

Since its founding, NASA has been dedicated to the advancement of aeronautics and space science. The NASA Scientific and Technical Information (STI) Program Office plays a key part in helping NASA maintain this important role.

The NASA STI Program Office is operated by Langley Research Center, the lead center for NASA's scientific and technical information. The NASA STI Program Office provides access to the NASA STI Database, the largest collection of aeronautical and space science STI in the world. The Program Office is also NASA's institutional mechanism for disseminating the results of its research and development activities. These results are published by NASA in the NASA STI Report Series, which includes the following report types:

- **TECHNICAL PUBLICATION.** Reports of completed research or a major significant phase of research that present the results of NASA programs and include extensive data or theoretical analysis. Includes compilations of significant scientific and technical data and information deemed to be of continuing reference value. NASA's counterpart of peer-reviewed formal professional papers but has less stringent limitations on manuscript length and extent of graphic presentations.
- **TECHNICAL MEMORANDUM.** Scientific and technical findings that are preliminary or of specialized interest, e.g., quick release reports, working papers, and bibliographies that contain minimal annotation. Does not contain extensive analysis.
- **CONTRACTOR REPORT.** Scientific and technical findings by NASA-sponsored contractors and grantees.

- **CONFERENCE PUBLICATION.** Collected papers from scientific and technical conferences, symposia, seminars, or other meetings sponsored or cosponsored by NASA.
- **SPECIAL PUBLICATION.** Scientific, technical, or historical information from NASA programs, projects, and mission, often concerned with subjects having substantial public interest.
- **TECHNICAL TRANSLATION.** English-language translations of foreign scientific and technical material pertinent to NASA's mission.

Specialized services that complement the STI Program Office's diverse offerings include creating custom thesauri, building customized databases, organizing and publishing research results . . . even providing videos.

For more information about the NASA STI Program Office, see the following:

- Access the NASA STI Program Home Page at <http://www.sti.nasa.gov/STI-homepage.html>
- E-mail your question via the Internet to [help@sti.nasa.gov](mailto:help@sti.nasa.gov)
- Fax your question to the NASA Access Help Desk at (443) 757-5803
- Telephone the NASA Access Help Desk at (443) 757-5802
- Write to:  
NASA Access Help Desk  
NASA Center for AeroSpace Information  
7115 Standard Drive  
Hanover, MD 21076-1320

NASA/TP—20F€—21íîî€



# International VLBI Service for Geodesy and Astrometry 2009 Annual Report

*Dirk Behrend (ed.)*  
*NVI, Inc., Greenbelt, Maryland*

*Karen D. Baver (ed.)*  
*NVI, Inc., Greenbelt, Maryland*

National Aeronautics and  
Space Administration

*Goddard Space Flight Center*  
*Greenbelt, MD 20771-0001*

---

**August 2010**

---

Available from:

NASA Center for Aerospace Information  
7121 Standard Drive  
Hanover, MD 21076-1320  
Price Code: A17

National Technical Information Service  
5285 Port Royal Road  
Springfield, VA 22161  
Price Code: A10

## Preface

This volume of reports is the 2009 Annual Report of the International VLBI Service for Geodesy and Astrometry (IVS). The individual reports were contributed by VLBI groups in the international geodetic and astrometric community who constitute the permanent components of IVS.

The IVS 2009 Annual Report documents the work of the IVS components for the calendar year 2009, our eleventh year of existence. The reports describe changes, activities, and progress of the IVS. Many thanks to all IVS components who contributed to this Annual Report.

The contents of this Annual Report also appear on the IVS Web site at

<http://ivscc.gsfc.nasa.gov/publications/ar2009>

This book and the Web site are organized as follows:

- The first section contains general information about IVS, a map showing the location of the components, information about the Directing Board members, and the annual report of the IVS Chair.
- The second section contains three special reports. The first is a reprint of the resolution with which the International Astronomical Union (IAU) adopted the Second Realization of the International Celestial Reference Frame (ICRF2) as the new celestial reference frame. The following two reports describe the VLBI Data Interchange Format (VDIF): an overview of the next VDIF format is followed by the detailed specifications (Release 1.0) of the format.
- The next seven sections hold the reports from the Coordinators and the reports from the IVS Permanent Components: Network Stations, Operation Centers, Correlators, Data Centers, Analysis Centers, and Technology Development Centers.
- The next section contains a compilation of publications in the field of geodetic and astrometric VLBI during 2009.
- The last section includes reference information about IVS: the Terms of Reference, the lists of Member and Affiliated organizations, the IVS Associate Member list, a complete list of IVS components, the list of institutions that contributed to this report, and a list of acronyms.



# Table of Contents

Preface .....	iii
<b>About IVS .....</b>	<b>1</b>
IVS Organization .....	2
IVS Component Map .....	4
IVS Directing Board .....	6
IVS Chair's Report .....	8
<b>Special Reports .....</b>	<b>11</b>
IAU Adopts ICRF2 as New Celestial Reference Frame .....	13
VLBI Data Interchange Format - An Overview .....	15
VLBI Data Interchange Format (VDIF) Specification .....	21
<b>IVS Coordination .....</b>	<b>37</b>
Coordinating Center Report .....	39
Analysis Coordinator Report .....	45
Network Coordinator Report .....	48
IVS Technology Coordinator Report .....	55
<b>Network Stations .....</b>	<b>61</b>
Badary Radio Astronomical Observatory .....	63
Fortaleza Station Report for 2009 .....	66
Goddard Geophysical and Astronomical Observatory .....	70
Hartebeesthoek Radio Astronomy Observatory (HartRAO) .....	74
Hobart, Mt. Pleasant Station and AuScope VLBI Project Report .....	78
Kashima 34-m Radio Telescope .....	81
Kashima and Koganei 11-m VLBI Stations .....	85
Kokee Park Geophysical Observatory .....	89
Matera CGS VLBI Station .....	93
The Medicina Station Status Report .....	97
VERA Geodetic Activities .....	99
Noto Station Status Report .....	103
Ny-Ålesund 20-meter Antenna .....	106
German Antarctic Receiving Station (GARS) O'Higgins .....	109
Onsala Space Observatory – IVS Network Station .....	113
Sheshan VLBI Station Report for 2009 .....	117
15 Years of Geodetic Experiments at the Simeiz VLBI Station .....	119
Svetloe Radio Astronomical Observatory .....	123
JARE Syowa Station 11-m Antenna, Antarctica .....	126
Geodetic Observatory TIGO in Concepción .....	130
Tsukuba 32-m VLBI Station .....	134
New Zealand 12-m VLBI Station .....	138
Westford Antenna .....	142
Geodetic Observatory Wettzell - 20 m Radiotelescope .....	146
Instituto Geográfico Nacional of Spain .....	150
Zelenchukskaya Radio Astronomical Observatory .....	154

<b>Operation Centers</b> .....	<b>157</b>
The Bonn Geodetic VLBI Operation Center .....	159
CORE Operation Center Report .....	161
NEOS Operation Center .....	164
<b>Correlators</b> .....	<b>167</b>
The Bonn Astro/Geo Mark IV Correlator .....	169
Haystack Observatory VLBI Correlator .....	173
IAA Correlator Center .....	177
VLBI Correlators in Kashima .....	180
Tsukuba VLBI Correlator .....	184
Washington Correlator .....	188
<b>Data Centers</b> .....	<b>191</b>
BKG Data Center .....	193
CDDIS Data Center Summary for the IVS 2009 Annual Report .....	195
Italy INAF Data Center Report .....	198
Data Center at NICT .....	199
Paris Observatory (OPAR) Data Center .....	203
<b>Analysis Centers</b> .....	<b>207</b>
Analysis Center of Saint Petersburg University .....	209
Geoscience Australia Analysis Center .....	211
Report for 2009 from the Bordeaux IVS Analysis Center .....	213
BKG/DGFI Combination Center Annual Report 2009 .....	217
Matera CGS VLBI Analysis Center .....	220
DGFI Analysis Center Annual Report 2009 .....	222
FFI Analysis Center .....	226
The BKG/IGGB VLBI Analysis Center .....	227
GSFC VLBI Analysis Center .....	231
Haystack Observatory Analysis Center .....	235
IAA VLBI Analysis Center Report 2009 .....	239
Vienna IGG Special Analysis Center Annual Report 2009 .....	243
Italy INAF Analysis Center Report .....	247
JPL VLBI Analysis Center Report for 2009 .....	249
KASI Combination Center Report .....	253
KTU-GEOD IVS Analysis Center Annual Report 2009 .....	257
IVS Analysis Center at Main Astronomical Observatory of National Academy of Sciences of Ukraine	259
Analysis Center at National Institute of Information and Communications Technology .....	261
Paris Observatory Analysis Center OPAR: Report on Activities, January - December 2009 .....	265
Onsala Space Observatory – IVS Analysis Center .....	267
Pulkovo IVS Analysis Center (PUL) 2009 Annual Report .....	271
SAI VLBI Analysis Center Report 2009 .....	274
SHAO Analysis Center 2009 Annual Report .....	278
U.S. Naval Observatory VLBI Analysis Center .....	280
USNO Analysis Center for Source Structure Report .....	284



<b>Technology Development Centers</b> .....	<b>289</b>
Canadian VLBI Technology Development Center .....	291
FFI Technology Development Center - Software Development .....	292
GSFC Technology Development Center Report .....	293
Haystack Observatory Technology Development Center .....	296
Technology Development Center at NICT .....	300
Onsala Space Observatory – IVS Technology Development Center .....	304
 <b>Bibliography</b> .....	 <b>309</b>
Bibliography .....	311
 <b>IVS Information</b> .....	 <b>325</b>
IVS Terms of Reference .....	327
IVS Member Organizations .....	337
IVS Affiliated Organizations .....	339
IVS Associate Members .....	340
IVS Permanent Components .....	350
Addresses of Institutions of Authors Contributing to this Report .....	354
List of Acronyms .....	361





About IVS

About IVS

# IVS Organization

## Objectives

IVS is an international collaboration of organizations which operate or support Very Long Baseline Interferometry (VLBI) components. The goals are:

1. To provide a service to support geodetic, geophysical and astrometric research and operational activities.
2. To promote research and development activities in all aspects of the geodetic and astrometric VLBI technique.
3. To interact with the community of users of VLBI products and to integrate VLBI into a global Earth observing system.

## The IVS

- Interacts closely with the IERS, which is tasked by IAU and IUGG with maintaining the international celestial and terrestrial reference frames (ICRF and ITRF),
- coordinates VLBI observing programs,
- sets performance standards for the observing stations,
- establishes conventions for data formats and products,
- issues recommendations for analysis software,
- sets standards for analysis documentation,
- institutes appropriate product delivery methods in order to insure suitable product quality and timeliness.

## Realization And Status Of IVS

### IVS consists of

- 27 Network Stations, acquiring high performance VLBI data,
- 3 Operation Centers, coordinating the activities of a network of Network Stations,
- 6 Correlators, processing the acquired data, providing feedback to the stations and providing processed data to analysts,
- 6 Data Centers, distributing products to users, providing storage and archiving functions,
- 26 Analysis Centers, analyzing the data and producing the results and products,
- 7 Technology Development Centers, developing new VLBI technology,
- 1 Coordinating Center, coordinating daily and long term activities.

### Altogether

- 76 Permanent Components, representing 39 institutions in 19 countries,
- ~280 Associate Members.

### In addition the IVS has:

- Directing Board, determining policies, standards and goals; the board is composed of 15 members (elected and ex officio), including
- Coordinators for the network, analysis and technology.

## ORGANIZATION OF INTERNATIONAL VLBI SERVICE

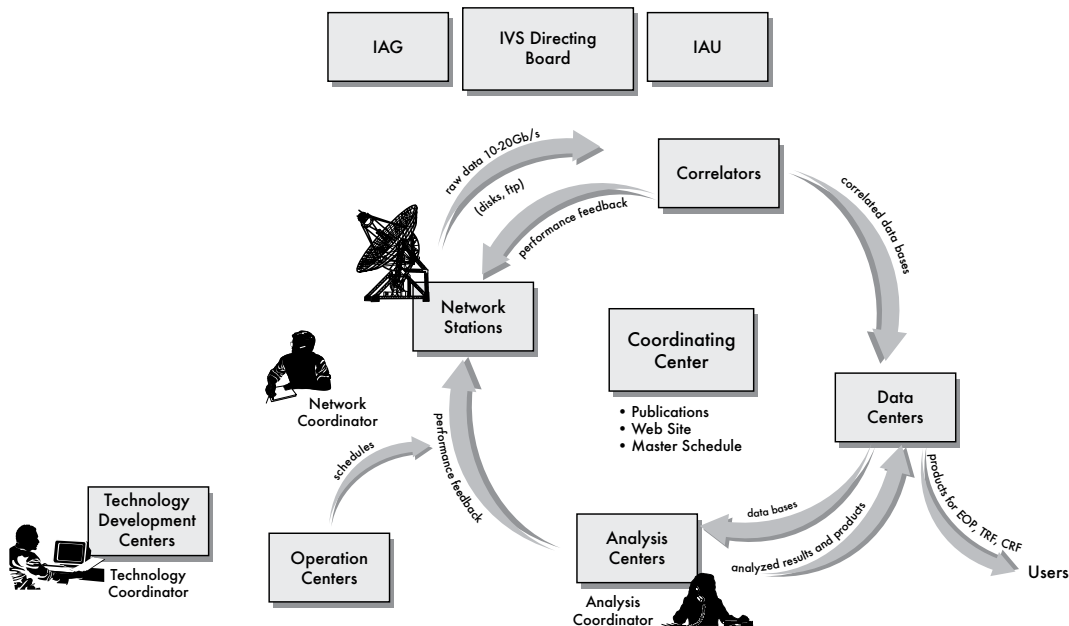

## IVS Member Organizations

The following organizations contribute to IVS by supporting one or more IVS components. They are considered IVS Members. Listed alphabetically by country.

Organization	Country
Geoscience Australia	Australia
University of Tasmania	Australia
Vienna University of Technology	Austria
Centro de Rádio Astronomia e Aplicações Espaciais	Brazil
Geodetic Survey Division, Natural Resources Canada	Canada
Dominion Radio Astrophysical Observatory	Canada
Universidad de Concepción	Chile
Instituto Geográfico Militar	Chile
Chinese Academy of Sciences	China
Observatoire de Paris	France
Observatoire de Bordeaux	France
Deutsches Geodätisches Forschungsinstitut	Germany
Bundesamt für Kartographie und Geodäsie	Germany
Institut für Geodäsie und Geoinformation der Universität Bonn	Germany
Forschungseinrichtung Satellitengeodäsie, TU-Munich	Germany
Max-Planck-Institut für Radioastronomie	Germany
Istituto di Radioastronomia INAF	Italy
Agenzia Spaziale Italiana	Italy
Geographical Survey Institute	Japan
National Institute of Information and Communications Technology	Japan
National Astronomical Observatory of Japan	Japan
National Institute of Polar Research	Japan
Auckland University of Technology	New Zealand
Norwegian Defence Research Establishment	Norway
Norwegian Mapping Authority	Norway
Astronomical Institute of St.-Petersburg University	Russia
Institute of Applied Astronomy	Russia
Pulkovo Observatory	Russia
Sternberg Astronomical Institute of Moscow State University	Russia
Hartebeesthoek Radio Astronomy Observatory	South Africa

Organization	Country
Korea Astronomy and Space Science Institute	South Korea
Instituto Geográfico Nacional	Spain
Chalmers University of Technology	Sweden
Karadeniz Technical University	Turkey
Main Astronomical Observatory, National Academy of Sciences, Kiev	Ukraine
Laboratory of Radioastronomy of Crimean Astrophysical Observatory	Ukraine
NASA Goddard Space Flight Center	USA
U. S. Naval Observatory	USA
Jet Propulsion Laboratory	USA

## IVS Affiliated Organizations

The following organizations cooperate with IVS on issues of common interest, but do not support an IVS component. Affiliated Organizations express an interest in establishing and maintaining a strong working association with IVS to mutual benefit. Listed alphabetically by country.

Organization	Country
Australian National University	Australia
University of New Brunswick	Canada
FÖMI Satellite Geodetic Observatory	Hungary
Joint Institute for VLBI in Europe (JIVE)	Netherlands
Westerbork Observatory	Netherlands
National Radio Astronomy Observatory	USA

## Products

### The VLBI technique contributes uniquely to

- Definition and realization of the International Celestial Reference Frame (ICRF)
- Monitoring of Universal Time (UT1) and length of day (LOD)
- Monitoring the coordinates of the celestial pole (nutation and precession)

### Further significant products are

- All components of Earth Orientation Parameters at regular intervals
- Station coordinates and velocity vectors for the realization and maintenance of the International Terrestrial Reference Frame (ITRF)

All VLBI data and results in appropriate formats are archived in data centers and publicly available for research in related areas of geodesy, geophysics and astrometry.

# IVS Component Map

## IVS Components by Country

Country	Qty.
Australia	2
Austria	1
Brazil	1
Canada	1
Chile	1
China	3
France	3
Germany	8
Italy	7
Japan	12
Norway	3
Russia	9
South Africa	1
South Korea	1
Spain	1
Sweden	3
Turkey	1
Ukraine	2
USA	16
<b>Total</b>	<b>76</b>

A complete list of IVS Permanent Components is in the IVS Information section of this volume.

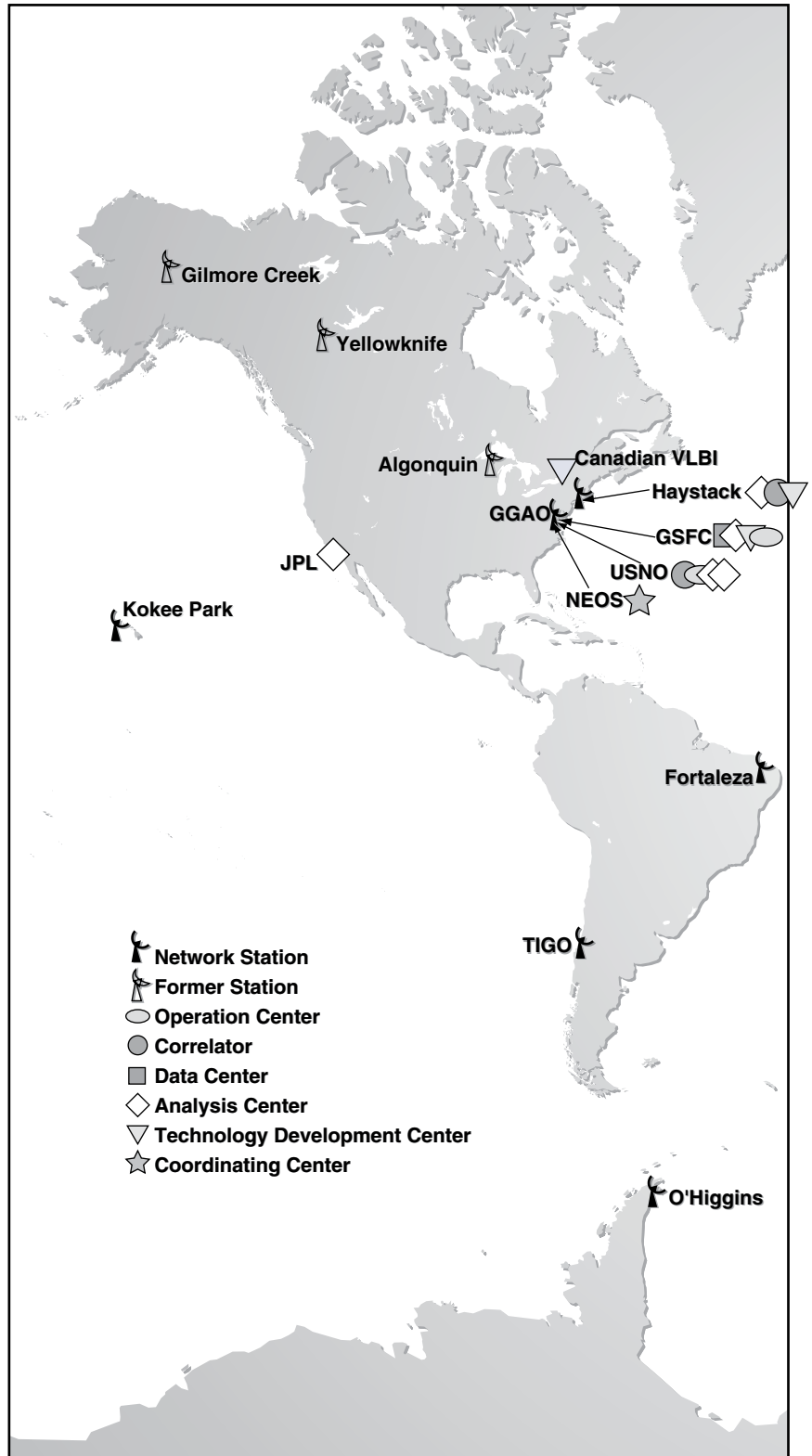



# IVS Directing Board



NAME: Harald Schuh  
AFFILIATION: Vienna University of Technology, Austria  
POSITION: Chair and IAG Representative  
TERM: ex officio



NAME: Dirk Behrend  
AFFILIATION: NVI, Inc./Goddard Space Flight Center, USA  
POSITION: Coordinating Center Director  
TERM: ex officio



NAME: Rüdiger Haas  
AFFILIATION: Chalmers University of Technology, Sweden  
POSITION: Technology Development Centers Representative  
TERM: Feb 2009 to Feb 2013



NAME: Patrick Charlot  
AFFILIATION: Bordeaux Observatory, France  
POSITION: IAU Representative  
TERM: ex officio



NAME: Hayo Hase  
AFFILIATION: Bundesamt für Kartographie und Geodäsie/TIGO, Germany/Chile  
POSITION: Networks Representative  
TERM: Feb 2007 to Feb 2011



NAME: Andrey Finkelstein  
AFFILIATION: Institute of Applied Astronomy, Russia  
POSITION: At Large Member  
TERM: Feb 2009 to Feb 2011



NAME: Ed Himwich  
AFFILIATION: NVI, Inc./Goddard Space Flight Center, USA  
POSITION: Network Coordinator  
TERM: permanent





NAME: Kerry Kingham  
 AFFILIATION: U.S. Naval Observatory, USA  
 POSITION: Correlators and Operation Centers Representative  
 TERM: Feb 2007 to Feb 2011



NAME: Oleg Titov  
 AFFILIATION: Geoscience Australia, Australia  
 POSITION: Analysis and Data Centers Representative  
 TERM: Feb 2009 to Feb 2013



NAME: Chopo Ma  
 AFFILIATION: NASA Goddard Space Flight Center, USA  
 POSITION: IERS Representative  
 TERM: ex officio



NAME: Gino Tuccari  
 AFFILIATION: Istituto di Radioastronomia, Italy  
 POSITION: Networks Representative  
 TERM: Feb 2009 to Feb 2013



NAME: Axel Nothnagel  
 AFFILIATION: University of Bonn, Germany  
 POSITION: Analysis Coordinator  
 TERM: permanent



NAME: Alan Whitney  
 AFFILIATION: Haystack Observatory, USA  
 POSITION: Technology Coordinator  
 TERM: permanent



NAME: Kazuhiro Takashima  
 AFFILIATION: Geographical Survey Institute, Japan  
 POSITION: At Large Member  
 TERM: Feb 2009 to Feb 2011



NAME: Xiuzhong Zhang  
 AFFILIATION: Shanghai Astronomical Observatory, China  
 POSITION: At Large Member  
 TERM: Feb 2009 to Feb 2011

Harald Schuh  
Institute of Geodesy and Geophysics, Vienna University  
of Technology

With the 2009 Annual Report, the IVS components report about their progress and activities which were conducted during the service's eleventh year of existence. I would like to thank all IVS Associate Members for their contributions over the course of the year, in particular for providing their reports on time. The timely appearance of the Annual Report is always an ambitious goal and is highly appreciated for maintaining this volume as a real information exchange tool for the community and related groups. I thank the editors for the timely release.

In 2009, IVS observing activities could be continued comparable to the previous years; a fact that, in view of the limited resources and failures of a few aging radio telescopes, can be attributed to optimized coordination by the Coordinating Center and strong support from all components. I would like to thank the staff of the Coordinating Center, who bear much responsibility and carry a heavy burden for the entire service activities. The day-to-day work done continuously at the Network Stations, the Correlators, the Data Centers, and the Analysis Centers is the basis for the regular provision of precise IVS products. From the many activities performed in 2009, I would like to emphasize a few that go beyond the normal work load.

## **IVS Contribution to the Global Geodetic Observing System (GGOS)**

Integration and combination in the framework of the Global Geodetic Observing System (GGOS) of the International Association of Geodesy (IAG) will be one of the major challenges for the international geodesy in the next decades. GGOS will go beyond the integration of the geodetic space techniques (VLBI, SLR, GNSS, and DORIS) as it includes also techniques measuring terrestrial gravity, the global Earth gravity field, sea level, and even the magnetic field. Thus, a consistent combination of all geometric and physical techniques will be required. GGOS plays an essential role in helping to solve environmental and societal problems. Many tasks such as establishing a global unified height system or open questions related to global change, sea level rise, or the prevention of natural hazards need precise reference frames and exact geodetic measurements. VLBI can give a critical contribution to GGOS by its relation to a quasi-inertial celestial reference frame and its unique ability to measure long-term UT1-UTC and precession/nutation. One of the IVS main tasks in 2009 was to continue its

contribution as an efficient and reliable partner within GGOS as well as to increase the awareness in the public and in the scientific community about the importance of VLBI. Several GGOS events were attended in 2009 with presentations about the IVS and the next generation VLBI system (VLBI2010). The IVS is well represented in the GGOS Steering Committee. At the IAG Scientific Assembly in Buenos Aires in September 2009, the IAG decided that GGOS should be the portal for all products provided by the individual IAG Services. Thus, all IVS products have become GGOS products as well.

## **VLBI2010 and the VLBI2010 Committee (V2C)**

The VLBI2010 Committee (V2C), chaired by Bill Petrachenko, was established by the IVS Directing Board in 2005. It is tasked with promoting the ambitious goals set by the VLBI2010 vision paper released by the IVS Working Group 3 "VLBI2010: Current and Future Requirements for Geodetic VLBI Systems". All results have been summarized in the excellent V2C Progress Report "Design Aspects of the VLBI2010 System" with recommendations that can be used as benchmark for new VLBI systems. The report was finalized in spring 2009 and published in printed and electronic form (e.g., <ftp://ivsc.gsfc.nasa.gov/pub/misc/V2C/TM-2009-214180.pdf>). I would like to thank all members of the V2C for taking on the responsible leading role in the realization of the VLBI2010 vision.

Meanwhile several countries have decided to invest into new VLBI systems. One has to highly appreciate that Geoscience Australia (GA), Australia; Auckland University of Technology (AUT), New Zealand; Korea Astronomy & Space Science Institute (KASI) and National Geographic Information Institute (NGII), Korea; NASA Goddard Space Flight Center (GSFC), USA; Bundesamt für Kartographie und Geodäsie (BKG), Germany; Instituto Geográfico Nacional (IGN), Spain together with the Regional Government of the Azores, Portugal; and the National Astronomy and Ionosphere Center (NAIC), operated by Cornell University at Arecibo, Puerto Rico, started or continued their activities to implement new telescopes of the VLBI2010 type. I would like to congratulate them on their ambitious projects and wish them success for the realization in the next few years. Thus, at this point twelve VLBI2010 antennas have been approved and several proposals are under consideration or have already been submitted in countries like Norway, Russia, Finland, France, and Saudi Arabia. With new antennas and the expected re-opening of the Fairbanks radio telescope, the global coverage of geodetic VLBI is getting better, but it is still far from being optimal.

Thus, ideas and proposals for new stations are still more than welcome.

After providing a detailed description of the VLBI2010 concept, the next task for the IVS will be the realization. To support the implementation of VLBI2010 and to actively contact governmental entities and funding organizations, the VLBI2010 Project Executive Group (V2PEG) under the leadership of Hayo Hase was established in March 2009.

### **IVS Working Group 4 on “VLBI Data Structures”**

The IVS Working Group on “VLBI Data Structures” was established in September 2007 as a response to a strong need of new, common VLBI data structures. This working group examines the data structure currently used in VLBI data processing and investigates what data structure is likely to be needed in the future. It designs a data structure that meets current and anticipated requirements for individual VLBI sessions including a cataloguing, archiving, and distribution system. Further, it prepares the transition capability through conversion of the current data structure as well as cataloguing and archiving softwares to the new VLBI2010 system. John Gipson, Chair of Working Group 4, gave several presentations about the new format that is based on the Network Common Data Form (NetCDF).

### **New IVS Working Groups in 2009**

Two new working groups were established at the 22nd Directing Board meeting in Buenos Aires in August 2009:

- Working Group 5 on Space Science Applications (chair: Leonid Gurvits) and
- Working Group 6 on VLBI Education and Training (chair: Rüdiger Haas).

So far, these new working groups have provided their charters and member lists and it can be expected that in 2010 they will actively tackle their particular tasks.

### **Events in 2009**

On March 18-20, 2009, the IVS VLBI2010 Workshop on Future Radio Frequencies and Feeds was held in Wetzell/Höllenstein, Germany. This workshop was another important milestone for the IVS on the way to realizing VLBI2010.

On March 22, 2009 the 21st Directing Board meeting was held at Bordeaux Observatory and in the following week (starting March 23, 2009) the 19th European VLBI for Geodesy and Astrometry (EVGA) Working Meeting and an IVS Analysis Workshop were held in Bordeaux.

In addition, the IVS/IERS Working Group on the Second Realization of the ICRF also met. The scientific organization of the meetings was performed in close collaboration with the IVS Analysis Coordinator and Chair of the EVGA, Axel Nothnagel; the local organizing committee was led by Patrick Charlot.

A special highlight was certainly the IVS 10th Anniversary Celebration on March 25, 2009—almost exactly 10 years after the IVS started to officially exist. During this event, which was attended by more than 100 people and streamed online by a science channel <http://canal2.u-strasbg.fr/evenements.asp?annee=2009&page=9&idEvenement=462>, several extremely interesting presentations were given covering not only the past 10 years, but also the full history of geodetic VLBI starting in the 1960ies in the USA, Canada, and Russia. Thanks a lot to the local organizer Patrick Charlot and his team for making the IVS 10th Anniversary Celebration a memorable event.

The 5th IVS Technical Operations Workshop (TOW2009) was held at the Haystack Observatory in the period April 27-30, 2009. TOW is an important meeting for exchanging experience in operation and for providing information about new developments. “Hands on” training and teaching in classes is the key for the success of TOW. It was another very useful meeting of this type and I would like to thank Ed Himwich and the local organizers at Haystack for their commitment to the TOW.

On August 29, 2009 the 22nd Directing Board Meeting was held in Buenos Aires, just before the Scientific Assembly of the IAG. I take this opportunity to thank Claudio Brunini, University of La Plata, Argentina for arranging the meeting facilities and making the stay a very pleasant one.

Finally, I would like to mention the “VLBI super session” which was run on November 18-19, 2009 with 33 radio telescopes observing more than 240 of the ICRF2 defining sources—the largest geodetic VLBI session that ever took place—as the IVS contribution to IAU’s International Year of Astronomy 2009. Several press releases and a number of outreach activities were issued regarding this session.

In 2009, two IVS Combination Centers were approved (BKG/DGFI, Germany and KASI, Korea), one new Operational Analysis Center (DGFI, Germany), and two new Associate Analysis Centers (Sternberg Astronomical Institute Moscow, Russia) and Karadeniz Technical University (KTU), Trabzon, Turkey were also accepted. Welcome to the club!

# IVS Chair's Report Continued

---

Summary information about all IVS events and activities is available on the IVS homepage <http://ivscc.gsfc.nasa.gov> and in the IVS Newsletter, issues 23 through 25. The Newsletter is an excellent means to transfer information to everybody. The editor team, Dirk Behrend, Hayo Hase, and Heidi Johnson, presented interesting and up-to-date information. They once again did an excellent job, which is highly appreciated.

## **The Directing Board in 2009**

The elections of new Directing Board members for the term 2009 to 2013 were held in December 2008. Gino Tuccari (IRA, Italy) was elected as Networks Representative, Oleg Titov (Geoscience Australia) as Analysis and Data Centers Representative, and Rüdiger Haas (OSO, Sweden) for the Technology Development Centers. For the at-large positions (term 2009 to 2011), Andrey Finkelstein (IAA, Russia), Xiuzhong Zhang (SHAO, China), and Kazuhiro Takashima (GSI, Japan) were re-appointed by the Directing Board in January 2009. I am very pleased that the IVS Directing Board is well balanced in its composition with respect to global coverage and with respect to component representation, and that the Directing Board contains a good mixture of experienced and young members.



Special Reports

Special Reports



## IAU Adopts ICRF2 as New Celestial Reference Frame

The Second Realization of the International Celestial Reference Frame (ICRF2) was adopted at the XXVII General Assembly of the International Astronomical Union (IAU) in Rio de Janeiro, Brazil as Resolution B3. The ICRF2 replaced the previously used first realization (ICRF) effective 1 January 2010. The International Earth Rotation and Reference Systems Service (IERS) published ([http://www.iers.org/nm\\_11216/IERS/EN/Publications/TechnicalNotes/tn35.html](http://www.iers.org/nm_11216/IERS/EN/Publications/TechnicalNotes/tn35.html)) Technical Note #35 about the computation of the ICRF2. The ICRF2 was an effort of a joint IERS/IVS working group and was overseen by an IAU working group. ICRF2 contains precise positions of 3,414 compact extragalactic radio sources, more than five times the number in the ICRF. Further, the ICRF2 is found to have a noise floor of  $\sim 40$  microarcseconds, some 5–6 times better than ICRF, and an axis stability of  $\sim 10$  microarcseconds, nearly twice as stable as ICRF. Alignment of ICRF2 with the International Celestial Reference System (ICRS) was made using 138 stable sources common to both ICRF2 and ICRF-Ext2. We reproduce here the full wording of the original resolution.

---

### IAU 2009 Resolution B3

on the

#### Second Realization of the International Celestial Reference Frame

The International Astronomical Union XXVII General Assembly,

**noting**

1. that Resolution B2 of the XXIII General Assembly (1997) resolved “That, as from 1 January 1998, the IAU celestial reference system shall be the International Celestial Reference System (ICRS)”,
2. that Resolution B2 of the XXIII General Assembly (1997) resolved that the “fundamental reference frame shall be the International Celestial Reference Frame (ICRF) constructed by the IAU Working Group on Reference Frames”,
3. that Resolution B2 of the XXIII General Assembly (1997) resolved “That IERS should take appropriate measures, in conjunction with the IAU Working Group on reference frames, to maintain the ICRF and its ties to the reference frames at other wavelengths”,
4. that Resolution B7 of the XXIII General Assembly (1997) recommended “that high-precision astronomical observing programs be organized in such a way that astronomical reference systems can be maintained at the highest possible accuracy for both northern and southern hemispheres”,
5. that Resolution B1.1 of the XXIV General Assembly (2000) recognized “the importance of continuing operational observations made with Very Long Baseline Interferometry (VLBI) to maintain the ICRF”,

**recognizing**

1. that since the establishment of the ICRF, continued VLBI observations of ICRF sources have more than tripled the number of source observations,
2. that since the establishment of the ICRF, continued VLBI observations of extragalactic sources have significantly increased the number of sources whose positions are known with a high degree of accuracy,
3. that since the establishment of the ICRF, improved instrumentation, observation strategies, and application of state-of-the-art astrophysical and geophysical models have significantly improved both the data quality and analysis of the entire relevant astrometric and geodetic VLBI data set,
4. that a working group on the ICRF formed by the International Earth Rotation and Reference Systems Service (IERS) and the International VLBI Service for Geodesy and Astrometry (IVS), in conjunction with the IAU Division I Working Group on the Second Realization of the International Celestial Reference Frame has finalized a prospective second realization of the ICRF in a coordinate frame aligned to that of the ICRF to within the tolerance of the errors in the latter (see note 1),
5. that the prospective second realization of the ICRF as presented by the IAU Working Group on the Second Realization of the International Celestial Reference Frame represents a significant improvement in terms of source selection, coordinate accuracy, and total number of sources, and thus represents a significant improvement in the fundamental reference frame realization of the ICRS beyond the ICRF adopted by the XXIII General Assembly (1997),

**resolves**

1. that from 01 January 2010 the fundamental astrometric realization of the International Celestial Reference System (ICRS) shall be the Second Realization of the International Celestial Reference Frame (ICRF2) as constructed by the IERS/IVS working group on the ICRF in conjunction with the IAU Division I Working Group on the Second Realization of the International Celestial Reference Frame (see note 1),
2. that the organizations responsible for astrometric and geodetic VLBI observing programs (e.g. IERS, IVS) take appropriate measures to continue existing and develop improved VLBI observing and analysis programs to both maintain and improve ICRF2,
3. that the IERS, together with other relevant organizations continue efforts to improve and densify high accuracy reference frames defined at other wavelengths and continue to improve ties between these reference frames and ICRF2.

*Note 1: The Second Realization of the International Celestial Reference Frame by Very Long Baseline Interferometry, Presented on behalf of the IERS / IVS Working Group, Alan Fey and David Gordon (eds.). (IERS Technical Note ; 35) Frankfurt am Main: Verlag des Bundesamts für Kartographie und Geodäsie, 2009. See <[www.iers.org/MainDisp.csl?pid=46-25772](http://www.iers.org/MainDisp.csl?pid=46-25772)> or <[hpiers.obspm.fr/icrs-pc/](http://hpiers.obspm.fr/icrs-pc/)>.*



# VLBI Data Interchange Format - An Overview

*Alan Whitney, Mark Kettenis, Chris Phillips, Mamoru Sekido*

## Abstract

One important outcome of the 7th International e-VLBI Workshop in Shanghai in June 2008 was the creation of a task force to study and recommend a universal VLBI data format that is suitable for both on-the-wire e-VLBI data transfer, as well as direct disk storage. This task force, called the VLBI Data Interchange Format (VDIF) Task Force, is the first part of a two-part effort, the second of which is addressing standardization of VLBI Transmission Protocols (VTP). The formation of the VDIF Task Force was prompted particularly by increased e-VLBI activity and the difficulties encountered when data arrive at a correlator in different formats from various instruments in various parts of the world. The Task Force proposed a streaming packetized data format that may be used for real-time and non-real-time e-VLBI, as well as direct disk storage. The data may contain multiple channels of time-sampled data with an arbitrary number of channels, arbitrary #bits/sample up to 32, ‘real’ or ‘complex’ data; data rates in excess of 100 Gbps are supported. Each data packet is completely self-identifying via a short header, and data may be decoded without reference to any external information. The VDIF Release 1.0 specification was ratified at the 8th International e-VLBI Workshop held in Madrid, Spain in June 2009, and is now being supported in several VLBI data systems currently under development. At the same meeting, a VTP Task Force, chaired by Chris Phillips of ATNF, was appointed to address the standardization of VLBI Transmission Protocols, which is an important follow-on to VDIF; the work of this group is now underway.

## 1. Introduction

The VLBI Standard Interface (VSI) specifications—developed in the early 2000s and designated VSI-H and VSI-S—are aimed primarily at recording and playback systems, and they specify standards for a hardware/electrical VLBI data interface and a software control interface, respectively. These VSI specifications intentionally *do not address the format of the transported data*.

In recent years, a number of new VLBI data acquisition and capture systems have appeared, along with the increasing need to interchange data on a global scale, including real-time and near real-time transfer via high-speed network, as well as by standard disk-file transfer. These types of data transfers have been increasingly plagued by the lack of an internationally agreed upon data format, often requiring *ad hoc* format conversions that require both programming effort and computing/storage resources. Recognizing this problem, a so-called VSI-E (‘E’ for ‘e-VLBI’) specification, based on standard RTP/RTCP network protocol, was first proposed and implemented in 2003-2004, which specified both data formats and data transport mechanisms for real-time e-VLBI data transfer. Although VSI-E was comprehensive, it was never formally ratified by the larger VLBI community. Its adoption was further hampered by its complexity, and it has been largely abandoned.

The VLBI Data Interface Specification (VDIF) has a somewhat different goal from VSI-E, specifying only a *standardized transport-independent VLBI data interchange format that is suitable for all types of VLBI data transfer, including real-time and near-real-time e-VLBI, as well as disk-file storage*. The VDIF specification, unlike VSI-E, explicitly makes no attempt to define an on-the-wire data transport protocol, which is expected to be the subject of a subsequent specification document. The combination of VDIF, along with this follow-on data transport protocol specification will, when completed, essentially constitute a replacement for VSI-E. And although the VDIF specification makes no mention of data transport protocol, it has been developed with

an awareness of expected methods of data transport, including network transport using various standard protocols, as well as physical or electronic transport of standard disk files.

## 2. VDIF Task Force

The 2008 International e-VLBI Workshop, held 14-17 June 2008 in Shanghai, China, included panel and group discussions specifically targeting the subject of creating an international data format standard. Those discussions led to the creation of a small, broadly-based international task force (subsequently known as the VDIF Task Force) to study the problem and make recommendations to the larger VLBI community. The proposed VDIF specification developed by the Task Force was ratified by the community at the 2009 International e-VLBI Workshop held in Madrid, Spain 22-26 June 2009.

## 3. Basic VDIF Structure

The discussions at the Shanghai meeting supported the concept of a ‘framed’ data stream format consisting of a stream of “Data Frames”, each containing a short self-identifying Data Frame Header, followed by a Data Array (containing the actual samples), as shown in Figure 1. A similar format is already used by several current and proposed disk-based recording systems.

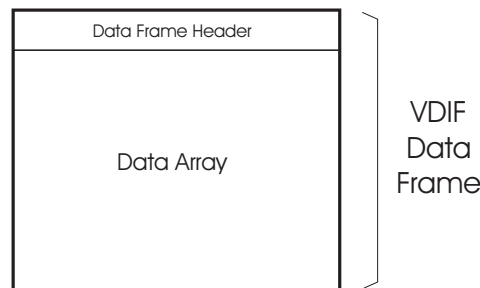

Figure 1. VDIF Data Frame structure showing Data Frame Header and Data Array

Accordingly, the VDIF specification is based upon a basic self-identifying Data Frame, which carries a time segment of time-sampled data from one or more frequency sub-bands. The length of a Data Frame may be chosen by the user to best match the chosen transport protocol; for example, in the case of real-time network transfer, a VDIF Data Frame length would normally be chosen so that exactly one Data Frame is carried by each on-the-wire packet. It is important to emphasize that the VDIF Data Frame is fundamentally transport-protocol independent, so that exactly the same set of Data Frames can represent VLBI data through a network transfer or be stored to a physical disk file.

In some cases, an entire set of sampled frequency sub-bands (or ‘channels’) may be carried in each Data Frame. In other cases, a single Data Frame may carry data from only a single data sub-band (channel) from among a set of many, in which case a logically parallel set of Data Frames is needed to represent the entire data set. In the VDIF concept, each time-series of Data Frames from the same set of sub-band(s) is known as a ‘Data Thread’, where each of the Data Frames within the Data Thread is identified by a ‘Thread ID’ embedded in the Data Frame Header. For actual transmission over a serial-data network, or for storage on a disk file, the set of Data Threads

that comprise the data set are merged into a single serial 'Data Stream'. Figure 2 shows schematic example of a Data Stream comprised of three Data Threads. The collection of Data Threads from the beginning to end of a particular observation, typically lasting seconds to minutes, is known as a Data Segment.

In normal usage, it is expected that two types of Data Streams will predominate: 1) a Data Stream consisting of a single Data Thread carrying multi-channel Data Frames or 2) a Data Stream consisting of multiple single-channel Data Threads, though mixing of single-channel and multi-channel Data Threads is not prohibited.

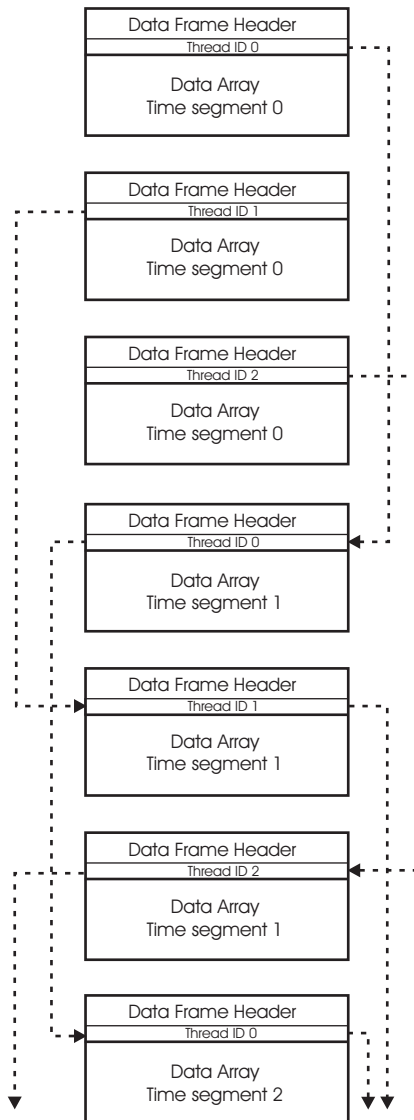

Figure 2. Illustration of Data Threads within a Data Stream

### 4. VDIF Attributes

The following considerations guided the creation of the VDIF specification:

1. The data in each Data Stream must be decodable using only information embedded within its constituent Data Frames.
2. A Data Thread may be discontinuous in time at the resolution of a Data Frame (e.g., transmitting and capturing Data Frames only during the active part of a pulsar period)
3. Each Data Frame may carry single-bit or multiple-bit samples up to 32 bits/sample.
4. Up to a maximum of 1024 Data Threads, each with a unique Thread ID, may be included in a single Data Stream.
5. A minimum of data manipulation should be necessary to move data between various data transmission techniques (e.g., disk file or real-time transfer).
6. Data rates of up to at least ~100 Gbps should be supported.
7. The data overhead (e.g., embedded auxiliary information required to meet the VDIF requirements) must be as low as practical.
8. Observations over leap seconds and year boundaries must be transparently supported.
9. The VDIF data format must be compatible, in as natural a way as possible, with all expected data transport methods (e.g., network transfer, file transfer, etc.).
10. Some limited amount of auxiliary user-defined data should be allowed in the Data Stream.
11. Within certain defined limits, out-of-time-order data within a Data Thread should be accommodated.

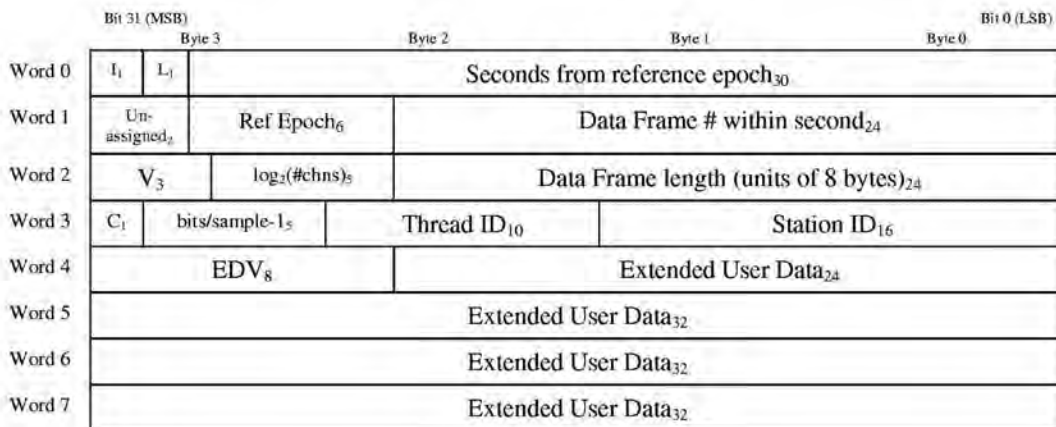

Figure 3. VDIF Data Frame Header format; subscripts are field lengths in bits; byte #s indicate relative byte addresses within a 32-bit word (little endian format)

## 5. Data Frame Rules

The following rules govern each VDIF Data Frame within a given Data Thread.

Each Data Frame contains a Data Frame Header followed by a Data Array.

1. All Data Frames must have the same Data Frame Header length, Data Array length, #channels, #bit/sample and Station ID.
2. If a Data Frame contains data from multiple channels, the same time-tag must apply across channels.
3. If a Data Frame contains multiple channels, all channels must be sampled with the same number of bits/sample.
4. Each Data Array contains sample data from one or more channels with the format (Section 9) and the encoding (Section 10) specified by VDIF.
5. The Data Frame length (including the Data Frame header) for each Data Thread must meet the following criteria:
  - (a) Must be a multiple of 8 bytes (for maximum compatibility with various computer-memory-address schemes and disk-addressing algorithms).
  - (b) Must be chosen so that an integer number of complete Data Frames are created in a continuous data flow of exactly one-second duration.
6. Data Frame #0 of each one-second period must contain, as its first sample, the data taken on a second tick of UTC; note that, in the case of time-discontinuous data, Data Frame #0 may not always be present.

These rules are intended to cover both ‘on-the-wire’ e-VLBI data formats as well as disk-file formats. For ‘on-the-wire’ real-time e-VLBI, it is expected that each transmitted non-fragmented packet will contain a single VDIF Data Frame as its data payload, in which case the Data Frame length is normally restricted to the range  $\sim 64/9000$  bytes. These restrictions do not apply to disk-file data format, for which the Data Frame length is limited (by the number of bits available to specify the Data Frame length) to  $2^{27}$  bytes ( $\sim 134$  MBytes).

## 6. Data Frame Header

Each VDIF Data Frame carries a header as shown in Figure 3, which may be either 16 or 32 bytes in length, depending on whether the Extended User Data words are included.

Details of the fields in the VDIF Data Frame Header are available in the VDIF specification.

## 7. Byte Ordering

Byte ordering of both the Data Frame Header and the Data Frame is little-endian (Intel x86 order) based on 32-bit words, which is consistent with most existing disk-based systems and software-based correlators.

## 8. Data Frame Ordering

Data coming from a single data source (e.g., a single dBBC or DBE) will normally be transmitted in strict time order. If directly connected to a local recording device, the recorded data will almost certainly be recorded in exactly the same order. However, Data Frames transmitted through a switch or over a network are not guaranteed to arrive in order.

The VDIF specification does not mandate strict Data Frame ordering within a Data Thread, but a best effort should be made to do so. Some correlation equipment, particularly older types, may be sensitive to Data Frame order, in which case the requirements of Data Frame ordering will be dictated by the correlation equipment. Modern software correlators are generally rather tolerant of minor Data Frame re-ordering of the type that might occur.

## 9. Data Array Formats

VDIF specifies the format of a Data Array based *solely* on the `#channels` and `#bits/sample` specified in the corresponding Data Frame Header. Since these two pieces of information are contained in each Data Frame Header, the samples in each Data Frame may be decoded with no external information.

The number of channels that can be accommodated in a multi-channel Data Array are limited to  $2^n$ , but it is expected that most users will prefer to use single-channel Data Array. The use of multiple single-channel Data Threads both allow the user to transmit an arbitrary number of channels, as well as being a more compatible format for the evolving generation of software correlators.

Any number of bits/sample from 1 to 32 are supported, though the Data Array may contain some pad bits for certain values of bits/sample.

Samples may either be ‘real’ or may occur in ‘complex pairs’, such as are sometimes used in standard digital signal processing algorithms.

## 10. Sample Representation

VDIF-encoded data samples are represented by the desired number of bits in a fixed-point ‘offset binary sequence’, beginning with all 0’s for the most-negative sampled value to all 1’s for the most-positive sampled value. For example, 2-bit/sample coding is (in order from most negative to most positive) 00, 01, 10, 11. This coding is compatible with existing Mark 5B, K5 and LBADR disk-based VLBI data systems, though bit-ordering may be different in some cases.

## 11. Summary

The VDIF specification is one more piece of the on-going effort to achieve Global standardization of VLBI. It will work, however, only if VLBI community members are convinced that VDIF is good both for them and the greater community. Indications to date are that the VDIF is being well-received. The authors, as members of the VDIF Task Force, are, of course, always open to constructive comments and suggestions that may strengthen VDIF further. The full VDIF specification is available at <http://www.vlbi.org>.

# VLBI Data Interchange Format (VDIF) Specification

Release 1.0  
Ratified 26 June 2009  
Madrid, Spain

## 1. Introduction

The VLBI Standard Interface (VSI) specifications, developed in the early 2000's and designated VSI-H and VSI-S<sup>1</sup> and aimed primarily at recording and playback systems, specify standards for a hardware/electrical VLBI data interface and a software control interface, respectively. These VSI specifications intentionally do not address the format of the transported data.

In recent years, a number of new VLBI data-acquisition and capture systems have appeared, along with increasing need to interchange data on a global scale, including real-time and near-real-time transfer via high-speed network, as well as by standard disk-file transfer. These types of data transfers have been increasingly plagued by the lack of an internationally agreed data format, often requiring *ad hoc* format conversions that require both programming effort and computing/storage resources. Recognizing this problem, a so-called VSI-E ('E' for 'e-VLBI') specification, based on standard RTP/RTCP network protocol, was first proposed and implemented in 2003-2004, which specified both data formats and data-transport mechanisms for real-time e-VLBI data transfer. Though VSI-E was comprehensive, it was never formally ratified by the larger VLBI community. Its adoption was further hampered by its complexity, and it has been largely abandoned.

The VLBI Data Interface Specification (VDIF) has a somewhat different goal from VSI-E, specifying only a standardized transport-independent VLBI data-interchange format that is suitable for all types of VLBI data transfer, including real-time and near-real-time e-VLBI, as well as disk-file storage. The VDIF specification, unlike VSI-E, explicitly makes no attempt to define an on-the-wire data-transport protocol, which is expected to be the subject of a subsequent specification document. The combination of VDIF, along with this follow-on data-transport-protocol specification will, when completed, essentially constitute a replacement for VSI-E. And though the VDIF specification makes no mention of data-transport protocol, it has been developed with an awareness of expected methods of data transport, including network transport using various standard protocols, as well as physical or electronic transport of standard disk files.

## 2. VDIF Task Force

The 2008 International e-VLBI Workshop, held 14-17 June 2008 in Shanghai, China, included panel and group discussions specifically targeting the subject of creation an international data-format standard. Those discussions led to the creation of a small, broadly-based international task force (subsequently known as the VDIF Task Force) to study the problem and make recommendations to the larger VLBI community. This document is the result of the extensive deliberations and discussions of the VDIF Task Force, mostly via e-mail, as well as solicitation of comments and suggestions from key members of the broader VLBI community, and represents our best effort to answer the challenge presented to us.

---

<sup>1</sup> VSI-H and VSI-S specifications are available at <http://www.haystack.mit.edu/tech/vlbi/vsi/index.html>

### 3. Basic VDIF structure

The discussions at the Shanghai meeting supported the concept of a ‘framed’ data-stream format consisting of stream of “Data Frames”, each containing a short self-identifying Data Frame Header, followed by a Data Array (containing the actual samples), as shown in Figure 1. A similar format is already used by several current and proposed disk-based recording systems.

Accordingly, the VDIF specification is based upon a basic self-identifying Data Frame, which carries a time segment of time-sampled data from one or more frequency sub-bands. The length of a Data Frame may be chosen by the user to best match the chosen transport protocol; for example, in the case of real-time network transfer, a VDIF Data Frame length would normally be chosen so that exactly one Data Frame is carried by each on-the-wire packet. It is important to emphasize that the VDIF Data Frame is fundamentally transport-protocol independent, so that exactly the same set of Data Frames can represent VLBI data through a network transfer or be stored to a physical disk file.<sup>2</sup>

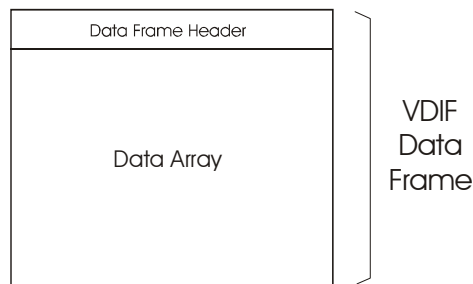

Figure 1: VDIF Data Frame structure showing Data Frame Header and Data Array

In some cases, an entire set of sampled frequency sub-bands (or ‘channels’) may be carried in each Data Frame. In other cases, a single Data Frame may carry data from only a single data sub-bands (channel) from among a set of many, in which case a logically parallel set of Data Frames is needed to represent the entire data set. In the VDIF concept, each time-series of Data Frames from the same set of sub-bands(s) is known as a ‘Data Thread’, where each of the Data Frames within the Data Thread is identified by a ‘Thread ID’ embedded in the Data Frame Header. For actual transmission over a serial-data network, or for storage on a disk file, the set of Data Threads that comprise the data set are merged into a single serial ‘Data Stream’. Figure 2 show a schematic example of a Data Stream comprised of three Data Threads. The collection of Data Threads from the beginning to end of a particular observation, typically lasting seconds to minutes, is known as a Data Segment.

In normal usage, it is expected that two types of Data Streams will predominate: 1) a Data Stream consisting of a single Data Thread carrying multi-channel Data Frames or 2) a Data Stream consisting of multiple single-channel Data Threads, though mixing of single-channel and multi-channel Data Threads is not prohibited.

---

<sup>2</sup> A VDIF-compliant disk file consists simply of a serial stream of VDIF Data Frames. A real-time VDIF data transfer, on the other hand, normally consists of a serial stream of network data packets, each containing a single VDIF Data Frame surrounded by various layers of transport protocol (TCP, UDP, IP, etc.) information. A stream of such network-transported VDIF Data Frames may be recorded directly to disk to create a valid VDIF-compliant data file. However, due to network packet-length restrictions, the reverse is not always true (i.e. a VDIF disk file could, for example, have valid Data Frame lengths much longer than can be supported in a single network packet), and the disk data would need to be “re-framed” to a different Data Frame length before network transmission using one packet per VDIF Data Frame. Normally, however, network transfer of a VDIF disk file would be done using ftp or similar file-transfer protocol that is independent of the VDIF specification.



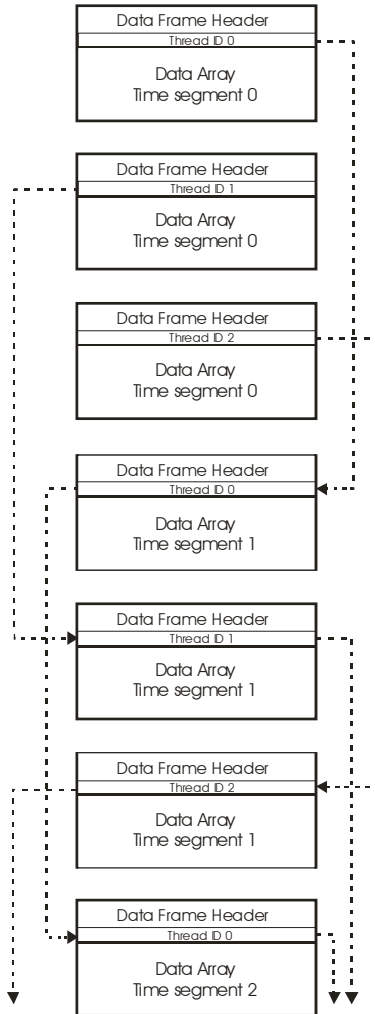

Figure 2: Illustration of Data Threads within a Data Stream

#### 4. VDIF attributes

The following considerations guided the creation of the VDIF specification:

1. The data in each Data Stream must be decodable using only information embedded within its constituent Data Frames, including a Stream ID, a time tag for the Data Array, the number of sampled channels, and the bits/sample. (This information should be sufficient to permit computation of spectra and state-statistics information without reference to any external information.)
2. A Data Thread may be discontinuous in time at the resolution of a Data Frame (e.g. transmit/capture Data Frames only during active part of a pulsar period)
3. Each Data Frame may carry single-bit or multiple-bit samples up to 32 bits/sample.
4. Up to maximum of 1024 Data Threads, each with a unique Thread ID, may be included in a single Data Stream.

5. A minimum of data manipulation should be necessary to move data between various data-transmission techniques (e.g. disk file or real-time transfer).
6. Data rates up to at least ~100 Gbps should be supported.
7. The data overhead (e.g. embedded auxiliary information required to meet the VDIF requirements) must be as low as practical.
8. Observations over leap seconds and year boundaries must be transparently supported.
9. The VDIF data format must be compatible, in as natural way as possible, with all expected data-transport methods (e.g. network transfer, file transfer, etc.).
10. Some limited amount of auxiliary user-defined data should be allowed in the Data Stream.
11. Within certain defined limits, out-of-time-order data within a Data Thread should be accommodated.

## 5. Data Frame Rules

The following rules govern each VDIF Data Frame within a given Data Thread:

1. Each Data Frame contains a Data Frame Header followed by a Data Array.
2. All Data Frames must have the same Data Frame Header length, Data Array length, #channels, #bit/sample and Station ID.
3. If a Data Frame contains data from multiple channels, the same time-tag must apply across channels.
4. If a Data Frame contains multiple channels, all channels must be sampled with the same number of bits/sample.
5. Each Data Array contains sample data from one or more channels with format (Section 9) and encoding (Section 10) specified by VDIF.
6. The Data Frame length (including Data Frame header) for each Data Thread must meet the following criteria:
  - a. Must be a multiple of 8 bytes (for maximum compatibility with various computer-memory-address schemes and disk-addressing algorithms).
  - b. Must be chosen so that an integer number of complete Data Frames are created in a continuous data flow of exactly one-second duration.
7. Data Frame #0 of each one-second period must contain, as its first sample, the data taken on a second tick of UTC; note that, in the case of time-discontinuous data, Data Frame #0 may not always be present.

### *Notes*

These rules are intended to cover both ‘on-the-wire’ e-VLBI data formats as well as disk-file formats. For ‘on-the-wire’ real-time e-VLBI, it is expected that each transmitted non-fragmented packet will contain a single VDIF Data Frame as its data payload, in which case the Data Frame length is normally restricted to the range ~64-9000 bytes<sup>3</sup>. These restrictions do not apply to disk-file data format, for which the Data Frame length is limited (by the number of bits available to specify the Data Frame length) to  $2^{27}$  bytes (~134 MBytes).

---

<sup>3</sup> In some cases, longer logical packets may be transmitted (UDP, for example, supports packet lengths up to 65527 bytes), but these packets are fragmented at the Ethernet layer and may not be suitable for some types of VLBI usage.

## 6. Data Frame Header

The standard 32-byte VDIF Data Frame Header is shown in Figure 3.

	Byte 3		Byte 2		Byte 1		Byte 0	
	Bit 31 (MSB)							Bit 0 (LSB)
Word 0	I <sub>1</sub>	L <sub>1</sub>	Seconds from reference epoch <sub>30</sub>					
Word 1	Un-assigned <sub>2</sub>		Ref Epoch <sub>6</sub>		Data Frame # within second <sub>24</sub>			
Word 2	V <sub>3</sub>		log <sub>2</sub> (#chans) <sub>5</sub>		Data Frame length (units of 8 bytes) <sub>24</sub>			
Word 3	C <sub>1</sub>	bits/sample-1 <sub>5</sub>		Thread ID <sub>10</sub>		Station ID <sub>16</sub>		
Word 4	EDV <sub>8</sub>			Extended User Data <sub>24</sub>				
Word 5	Extended User Data <sub>32</sub>							
Word 6	Extended User Data <sub>32</sub>							
Word 7	Extended User Data <sub>32</sub>							

Figure 3: VDIF Data Frame Header format; subscripts are field lengths in bits; byte #s indicate relative byte address within 32-bit word (little endian format)

The words within the Data Frame Header are assigned as follows:

### Word 0

Bit 31: Invalid data (i.e. data in this Data Frame has been tagged Invalid by the data source); valid=0, invalid=1

Bit 30: Legacy mode; see Note 1

‘0’ - standard 32-byte VDIF Data Frame header

‘1’ - legacy header-length mode; Words 4-7 omitted from header

Bits 29-0: Seconds from reference epoch; see Note 2

### Word 1

Bits 31-30: Unassigned (should be set to all ‘0’s)

Bits 29-24: Reference Epoch for second count; see Note 2

Bits 23-0: Data Frame # within second, starting at zero; must be integral number of Data Frames per second

### Word 2

Bits 31-29: VDIF version number; see Note 3

Bits 28-24: log<sub>2</sub>(#channels in Data Array); #chans must be power of 2; see Note 4

Bits 23-0: Data Frame length (including header) in units of 8 bytes; see Note 5

### Word 3

Bit 31: Data type; see Note 6

‘0’ - Real data

‘1’ - Complex data

Bits 30-26: #bits/sample-1 (32 bits/sample max); see Note 7

Bits 25-16: Thread ID (0 to 1023)

Bits 15-0: Station ID; see Note 8

### Words 4-7

Extended User Data: Format and interpretation of extended user data is indicated by the value of Extended Data Version (EDV) in Word 4 Bits 31-24; see Note 9

## Notes

1. For purposes of easing the transition from legacy VLBI disk-based data system to the VDIF standard, a ‘legacy header-length mode’ is supported, as specified in Word 3 bit 31. When this mode is active, Words 4-7 are omitted so that header length is reduced to 16 bytes, which is compatible with existing Mark 5B/K5/LBADR disk-based data systems. *Note: All Data Threads within a Data Stream must use the same frame-header length.*
2. The VDIF time code in Word 0 is divided into two fields:
  - a. Reference epoch: A 6-bit field in Word 1 that contains the 6-month period in which the VDIF clock was *set*, with an origin of at 00UTC 1 Jan 2000, such that ‘0’ corresponds to the first 6 months of 2000, ‘1’ corresponds to the 6 months starting 00H 1 July 2000, etc. After setting, this 6-bit field is static and is *not incremented*. This field rolls over to 0 again when the reference epoch corresponds to the 6-month period starting 00H 1 Jan 2032.
  - b. Seconds from reference epoch: A 30-bit field in Word 0 that is initially set to second count within 6-month period [i.e. (day number within a 6-month period, starting at zero)\*86400+(UTC second number within day)], and thereafter counts all seconds (including any leap seconds). This field counts seconds unambiguously for 34 years, then rolls-over back to 0 after reaching a count of  $2^{30}-1$ .

Note that the VDIF time-code format naturally supports observations through leap seconds and over year boundaries. However, the correlator must be aware of leap seconds which occur following the Reference Epoch. No knowledge of future leap seconds is required by the VDIF clock.

Some users may prefer to *always* fix the Reference Epoch to some particular value (such as 00UTC 1 Jan 2000). This is acceptable provided that all leap seconds are accounted for between the chosen Reference Epoch and the initial setting of the ‘seconds from reference epoch’ value.

3. The VDIF version number in Word 3 supports up to seven future VDIF frame-header formats to be defined, allowing decoding software to automatically determine and appropriately parse the corresponding Data Frame Header.
4. Theoretical maximum number of channels is  $2^{31} = 2,147,483,648$ , but in practice is probably much smaller (perhaps  $2^{16} = 65536$ ). For e-VLBI, where normally one full Data Frame is transmitted in each network data packet, the number of channels may be further limited by the maximum supported length of a network data packet.
5. The Data Frame length includes the Data Frame Header and must be a multiple of 8 bytes, with a maximum length of  $2^{27}$  bytes.
6. Each complex sample consists of two sample components, designated ‘I’ (In-phase) and ‘Q’ (Quadrature), each containing the same number of bits.
7. If the data type is ‘complex’, this parameter is set according to the #bits in each complex-sample component (i.e. half the total #bits per complex sample).
8. The 16-bit ‘Station ID’ field will accommodate the standard globally assigned 2-character ASCII ID. Or, if the number of stations is very large (SKA, for example), the Station ID may be numeric; in this case, the 16-bit field will be interpreted as an unsigned 16-bit integer. The two cases can be distinguished by the value of the first 8-bit character of the field; if this character has ASCII value  $<48_{10}$  (representing the zero character ‘0’), a numeric ID is assumed.
9. Extended Data Words 4-7 are available for user-generated data. Each different usage of the extended words should be assigned a different Extended Data Version (EDV) number in

Word 4 Bits 31-26 so that decoding software can automatically apply the proper decoding algorithm. EDV version numbers are listed and coordinated through the [www.vlbi.org/vsi](http://www.vlbi.org/vsi) website. Up to 255 different such versions can be accommodated; if Words 4-7 are unused, the value of EDV is set to '0' and the Extended User Data fields should be set to all '0's. Each VDIF version may have an independent set of EDV numbers.

It is worth noting that, within the first 16-bytes of the header (Word 0 through Word 3), only Words 0 and 1 contain data that change with time within a given Data Thread; data in Words 2 and 3 are static within the Data Thread.

### 7. Byte ordering

Byte ordering of both the Data Frame Header and Data Frame is little-endian (Intel x86 order) based on 32-bit words, which is consistent with most existing disk-based systems and software-based correlators.

### 8. Data Frame ordering

Data coming from a single data source (e.g. a single dBBC or DBE) will normally be transmitted in strict time order. If directly connected to a local recording device, the recorded data will almost certainly be recorded in exactly the same order. However, Data Frames transmitted through a switch or over a network are not guaranteed to arrive in order.

The VDIF specification does not mandate strict Data Frame ordering within a Data Thread, but a best effort should be made to so. Some correlation equipment, particularly older types, may be sensitive to Data Frame order, in which case the requirements of Data Frame ordering will be dictated by the correlation equipment. Modern software correlators are generally rather tolerant of minor Data Frame re-ordering of the type that might occur.

### 9. Data Array formats

VDIF specifies the format of a Data Array based solely on the #channels and #bits/sample specified in the corresponding Data Frame Header. Adherence to these specified formats is necessary to ensure that the data are properly interpreted.

#### 9.1 *Single-channel real-data Data Array Format*

The following rules apply to the composition of a Data Array carrying a single channel real data:

1. Each Data Array is composed of an even number of 32-bit words.
2. Each time sample is a single value of 1 to 32 bits.
3. The oldest data sample in each word occupies the field including Bit 0, with newer samples filling in adjacent higher-order bits until no more space is available for a full sample.
4. For multi-bit samples, the LSB of each sample occupies the most-LSB bit of the sample field.
5. A data sample may not cross a word boundary, but instead must be placed in next word; this may result in one or more unused high-order bits.
6. The first sample in a Data Array corresponds precisely to the time indicated in the Data Frame Header.

For Data Arrays carrying single-channel data, the Data Array formats for 1, 2, 3, 4, 20 and 32 bits/sample are shown in Figures 4 through 9; other values of bits/sample are formatted similarly, but are not illustrated here.



Figure 4: Real 1-bit/sample data-word format (numbers in boxes indicate relative sample #'s in time order); byte #s indicate relative byte address within 32-bit word (little endian format).

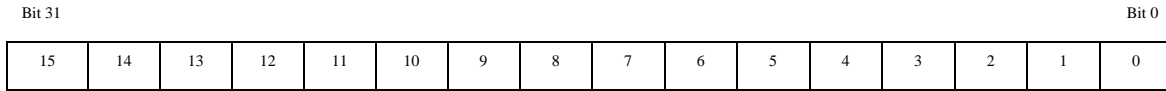

Figure 5: Real 2 bits/sample data-word format

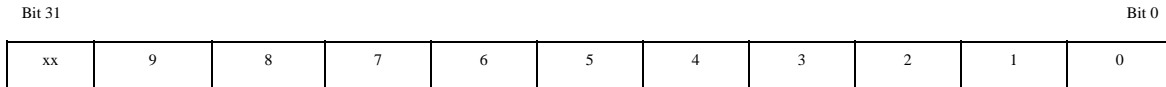

Figure 6: Real 3 bits/sample data-word format. 'xx' indicates unused bits (set to 0)

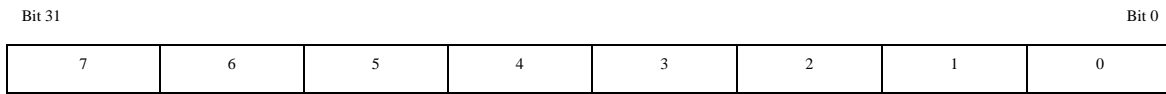

Figure 7: Real 4 bits/sample data-word format

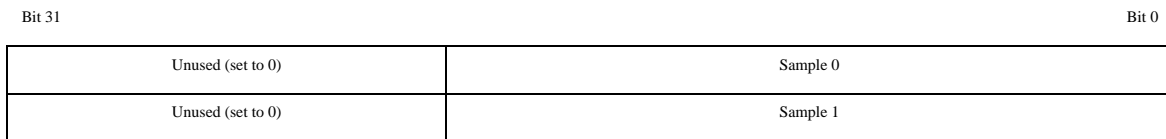

Figure 8: Real 20 bits/sample data-word format

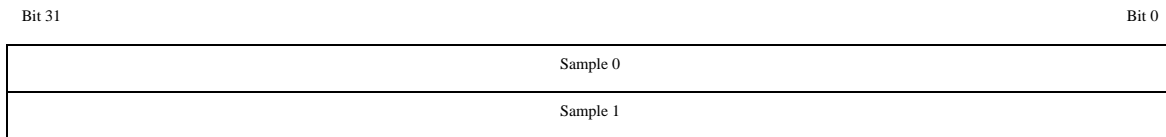

Figure 9: Real 32 bits/sample data-word format

This general scheme can be extended to an arbitrary number of bits/sample (up to 32), but a subtlety arises which must be recognized: For standard VLBI use, the number of samples/word must divide evenly into  $2^n \cdot 10^6$  samples/sec, which can never be satisfied for 5, 9 or 10 bits/sample. So the only legal bits/sample values in this regard are 1-4, 6-8 and 11-32 (the VDIF specification supports a maximum of 32 bits/sample). Interestingly, of all of these possibilities, only 3-bit and 6-bit samples have any storage-efficiency improvements over padding the bits/sample to the next power of 2.

### 9.2 Single-channel complex-data Data Array Format

The Data Array format for complex data is similar to real data, except that each complex sample consists of two scalar components, usually denoted as 'I' (for In-Phase) and 'Q' (for Quadrature), and each with the same number of bits. These two complex components are always treated as a pair and placed adjacent to each other as shown in Figure 10 through Figure 15, with the 'I' component always occupying the lower-order bits (or the first of two words when each sample component contains more than 16 bits). Note that the formatting is exactly the same as real data except that the two complex-component values occur in pairs.

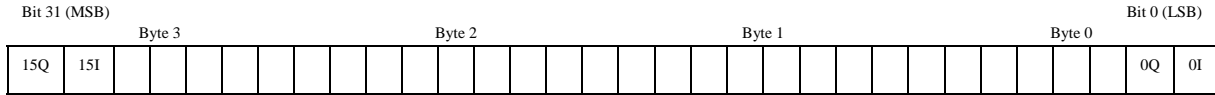

Figure 10: Complex 1-bit/sample-component data-word format; ‘I’ and ‘Q’ represent ‘In-phase’ and ‘Quadrature’ components; numbers in boxes indicate relative sample #'s in time order; byte #s indicate relative byte address within 32-bit word (little endian format)

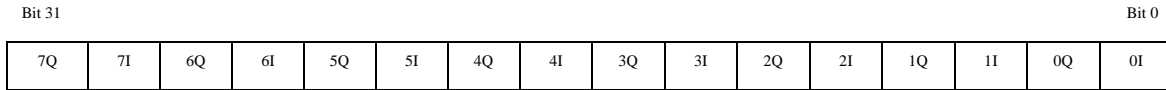

Figure 11: Complex 2 bits/sample-component data-word format

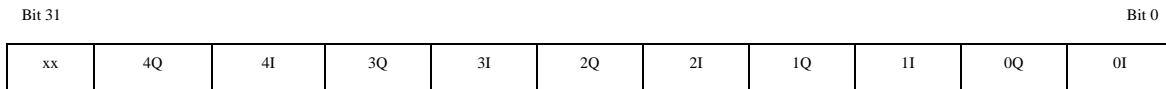

Figure 12: Complex 3 bits/sample-component data-word format. 'xx' indicates unused bits



Figure 13: Complex 4 bits/sample-component data-word format

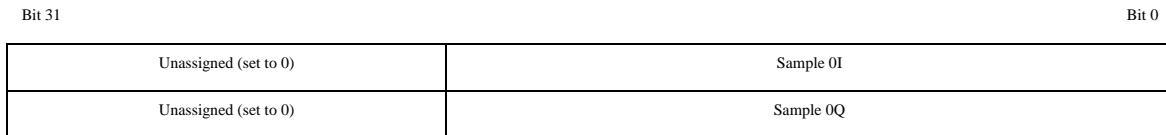

Figure 14: Complex 20 bits/sample-component data-word format

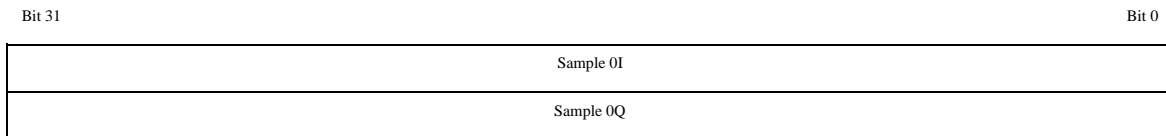

Figure 15: Complex 32 bits/sample-component data-word format

Note that, for complex data, the bits/sample parameter in the VDIF header refers to the number of bits in each complex *sample component*, not the total number of bits in the complex sample; this is required to support the case where each complex-sample component contains more than 16 bits since the Data Frame Header only supports a 5-bit binary field for specifying the sample length. Except for the case of >16 bits/sample-component, each 32-bit Data Array word always contains an integral number of complex samples regardless of the number of bits per sample. For the case of  $\geq 16$  bits/sample-component, each complex sample occupies two adjacent words (see Figure 14 and 15).

### 9.3 Multi-channel real-data Data Array format

For simplicity, and in accordance with historical VLBI practice, the VDIF specification for multi-channel Data Arrays supports only  $2^n$  channels with  $2^k$  bits/sample; maximum #channels is  $2^{31}=2,147,483,648$  and maximum bits/sample is  $2^5=32$ . Extension of these formats to include an arbitrary number of bits/sample is not contemplated. In such cases, users are strongly encouraged to use single-channel Data Threads, which do not impose this constraint.

For purposes of defining the multi-channel Data Array format, we define the term “complete sample”. A complete sample is the sample data from all channels for a single sample time, consisting of  $2^n * 2^k$  bits.

Three rules govern the filling of 32-bit data words into a multi-channel Data Array<sup>4</sup>:

1. Each individual-channel sample within a complete sample is represented by an adjacent set of  $2^k$  bits, with the  $2^0$  sample bit occupying the most LSB bit.
2. The resulting individual-channel samples within a single complete sample are packed into  $2^n$  adjacent clusters of  $2^k$  bits each, creating a formatted field of  $2^n * 2^k$  bits. Figure 16 through Figure 19 show 32-bit Data Array word usage for several example complete-sample lengths; other cases may be inferred.
3. Each Data Array must contain an integer number of complete samples (i.e. a complete sample may not span a Data Array boundary).

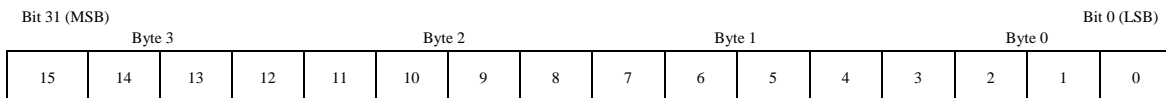

Figure 16: Data Array word for complete-sample length of 2 bits (i.e.  $2^n * 2^k = 2$ ); relative sample times are indicated in each 2-bit complete sample; byte #s indicate relative byte address within 32-bit word (little endian format)



Figure 17: Data Array word for complete-sample length of 8 bits (i.e.  $2^n * 2^k = 8$ ); relative sample times are indicated in each 8-bit complete sample

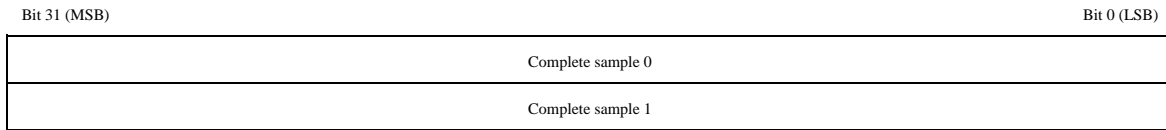

Figure 18: Data Array word for complete-sample length of 32 bits (i.e.  $2^n * 2^k = 32$ ); relative sample times are indicated in each 32-bit complete sample

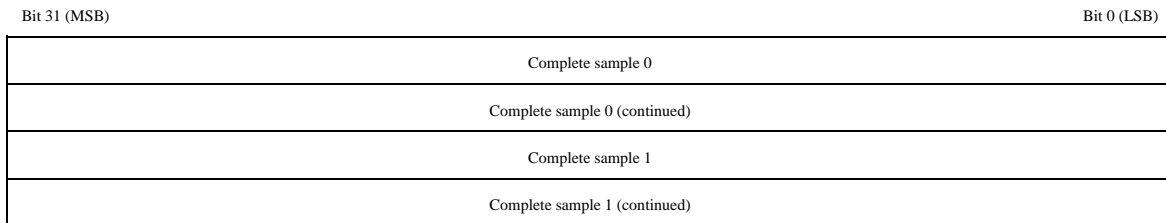

Figure 19: Data Array word for complete-sample length of 64 bits (i.e.  $2^n * 2^k = 64$ ); relative sample times are indicated in each 64-bit complete sample

<sup>4</sup> Legacy disk-based systems such as the Mark 5B, K5 and LBADR systems generally conform to rules 2 and 3, but are limited to cases where  $2^n \leq 32$  (i.e.  $\leq 32$  channels),  $2^k \leq 2$  (i.e. 1 or 2 bits/sample), and  $2^n * 2^k \leq 32$  (i.e. complete-sample length is limited to 32 bits). In some cases, bit-ordering of 2-bit samples in legacy systems does not conform to rule 1.



Caution: Note that the length of multi-channel Data Frames can be much more constrained than single-channel Data Frames due to the requirement that each Data Frame contains an integral number of complete samples. This is particularly problematic when the number of channels is large. Thus, multi-channel Data Frames may be significantly less suitable for e-VLBI transfer when it is desired to encapsulate one Data Frame per network packet. No such constraint normally exists for VDIF Data Frames stored in disk files or transferred via ftp.

#### 9.4 Multi-channel complex-data Data Array format

For multi-channel complex data, the number of channels is also limited to  $2^n$ , with each complex-sample component containing  $2^k$  bits, so that the length of a complete sample is  $2 \cdot 2^n \cdot 2^k$  bits. Within each complex sample, the 'I' and 'Q' (In-Phase and Quadrature, respectively) components are adjacent with the 'I' occupying the lesser-significant position; all samples with the same time tag are then packed adjacently into a complete sample of length  $2 \cdot 2^n \cdot 2^k$  bits. Samples cells are populated into the Data Array according to the three rules specified in Section 9.3.

#### 10. Sample representation

VDIF-encoded data samples are represented by the desired number of bits in a fixed-point 'offset binary sequence', beginning with all 0's for the most-negative sampled value to all 1's for the most-positive sampled value<sup>5</sup>. For example, 2-bit/sample coding is (in order from most negative to most positive) 00, 01, 10, 11.

#### 11. Non-continuous data

Note that the VDIF specification allows Data Frames that are discontinuous in time. For example, Data Frames may be generated or transmitted only over the active part of a pulsar pulse. This is a perfectly legitimate use of the VDIF. Each Data Frame stands on its own so that there is no ambiguity or confusion.

#### 12. Multiple Data Threads

Up to 1024 Data Threads may be mixed into a single Data Stream. Common usages would be 1) one Data Thread per channel in a multi-channel system, or 2) one or more multi-channel Data Threads, each with the same number of channels, sample rate and bits/sample. Arbitrary mixing of Data Threads is allowed within a single Data Stream, even with different sample rates, bits/sample, etc. In an effort to categorize types of multi-Thread Data Streams, we define below 'simple' and 'complex' Data Streams. Regardless of the type of Data Stream, the user is cautioned to verify that the intended receiving/processing target system can properly accept such a data flow. *Note: All Data Threads within a Data Stream must use the same frame-header length.*

##### 12.1 'Simple' VDIF Data Stream

Though the VDIF specification is quite flexible, even allowing a Data Stream to contain multiple Data Threads with different numbers of channels and even different sample rates and bits/sample, it is expected that most usage will be of two types: 1) one or more single-channel Data Threads, each with the same sample rate and bits/sample, and 2) one or more multi-channel Data Threads, each with the same number of channels, sample rate and bits/sample. We define both of these usage types as 'simple' Data Streams.

The rule for creation of a 'simple' Data Stream is as follows:

Each Data Thread within a 'simple' VDIF Data Stream must have the same #channels, #bits/sample, data type ('real' or 'complex'), #Data Frames/sec, Data Frame Header Length and Data Array length.

---

<sup>5</sup> This coding is compatible with existing Mark 5B, K5 and LBADR disk-based VLBI data systems, though bit-ordering may be different in some cases.

Note that Data Threads with different Station IDs are allowed within a ‘simple’ Data Stream.

It is useful to create a Format Designator to specify the characteristics of a ‘simple’ VDIF Data Stream to aid in logging and processing the data. The VDIF Format Designator is an ASCII character sequence defined as:

<total data rate<sup>6</sup> (Mbps)> - <total # chans> - <bits/sample> [- <#threads>]

where #threads is assumed to be “1” if the <#threads> parameter is not specified. For example, the Format Designator

1024-16-2-1

specifies a total data rate of 1024 Mbps divided into 16 channels of 2 bits/sample and formatted into a single (16-channel) Data Threads; since this is a single thread, the Format Designator ‘1024-16-2’ is equivalent (note this designator follows the widely used legacy VLBA recording mode designator). Another example – the Format Designator

1024-16-2-16

also specifies a total data rate of 1024 Mbps divided into 16 channels of 2 bits/sample, but formatted into 16 single-channel threads. One more example:

1024-16-2-4

again specifies a total data rate of 1024 Mbps divided into 16 channels of 2 bits/sample, but formatted into four 4-channel threads.

When using the VDIF Format Designator in any context where it might be confused with a mode or format designator of another type (for example, the legacy VLBA mode designator), it is suggested that the prefix ‘VDIF-’ be added – for example:

VDIF-1024-16-2-4

It is important to recognize that the VDIF Format Designator is a convenience only and is not required to decode the actual Data Stream. In fact, the VDIF Format Designator can always be re-constructed by reading a small section of the Data Stream.

## 12.2 ‘Compound’ VDIF Data Stream

A ‘compound’ Data Stream contains multiple intermixed ‘simple’ Data Streams, each of which independently adheres to the rule stated in Section 12.1.

The rules for creation of a ‘compound’ VDIF Data stream are as follows:

1. A ‘compound’ VDIF Data Stream is a merging of two or more ‘simple’ Data Streams.
2. The set of Thread ID numbers within each constituent ‘simple’ Data Stream must occupy an exclusive, non-overlapping numerical range.

The lowest numbered Thread ID in each such ‘simple’ Data Stream’ is defined as the Base Thread ID. Knowledge of the Base Thread ID for each constituent ‘simple’ Data Stream allows easy identification of all Data Threads within each constituent ‘simple’ Data Stream simply by examining the Thread ID in each Data Frame.

Usage of ‘compound’ Data Streams is discouraged unless the intended processing target is explicitly able to accept such a data format.

Within the context of a ‘compound’ Data Stream, each constituent ‘simple’ Data Stream is known as a Data Group, each of which has a corresponding ‘simple’ Data Thread Format Designator. The corresponding ‘compound’ Data Stream Format Designator is of the form

<DataGroup1 Designator> + <DataGroup2 Designator> + .....

---

<sup>6</sup> Actual total sample data rate, not including Frame Headers or pad bits in Data Arrays.

For example, '1024-16-2-16+256-8-2' specifies two 'simple' Data Streams within the 'compound' Data Stream, the first with a data rate of 1024 Mbps, 16 channels, 2 bits/channel in 16 threads, and the second with a data rate of 256 Mbps, 8 channels, 2 bits/sample in 1 thread.

### 13. Channel-numbering convention

Unique Channel identification with a Data Stream is often necessary for the proper specification of data handling or processing. For single-channel Data Threads, the most straightforward identifier is simply the numerical Thread ID. For channels within multi-channel Data Threads, a specification of the form '<ThreadID>-<chan# within thread>' (e.g. '5-2') seems most natural, where channel numbering begins at zero for the channel in the most LSB position of a sample cell and increments by one for each neighboring channel within the sample cell.

### 14. File-naming conventions

Disk files composed of Data Frames in VDIF format should be named with the suffix "vdif". Otherwise, file-naming should adhere to the internationally-agreed file-naming conventions specified at [www.vlbi.org/vsi](http://www.vlbi.org/vsi). In some cases it may be useful to include the VDIF Format Designator as part of the filename. For this purpose, it is suggested that the VDIF Format Designator be included in the file name as a VDIF-specific 'auxiliary info' field.

The filename format for a 'simple' VDIF-format data file is constructed as

<exp name>\_<station code>\_<scan name>[\_<auxinfo1>\_<auxinfo2>].vdif

where

<exp name> - experiment name; 16 chars max

<station code> - 2-character ASCII station code or decimal numeric value according to the rules specified in Note 8 of Section 6.

<scan name> - assigned scan name (derived from VEX file or other source); 16 chars max

<auxinfo> - (optional) auxiliary information field(s) in format 'ccppp' where 'cc' is a 'registered' 2-char identifier and 'ppp' is the information value in some specified format. For VDIF-format files, 'fd' is registered as the VDIF Format Designator. <auxinfo> identifiers are listed and coordinated through the [www.vlbi.org/vsi](http://www.vlbi.org/vsi) website.

An example filename for a VDIF-format file:

gre53\_ef\_scan035\_fd1024-16-2-16.vdif

which specifies data from experiment 'gre53', station 'ef', scan name 'scan035' containing data with VDIF Format Designator '1024-16-2-16'.

VDIF Task Force:

Mark Kettenis, JIVE  
Chris Phillips, CSIRO/ATNF  
Mamoru Sekido, NICT  
Alan Whitney, MIT (chair)

## Addendum 1: Glossary

Base Thread ID (see Data Stream)

Channel (Section 3): In the context of the VDIF specification, a “channel” is normally the time-sampled data from a single frequency sub-band.

Complete Sample (Section 9.3): Within a Data Array, a *complete sample* is the sample data from all data channels for a single sample time (relevant for multi-channel data only).

Data Array (Section 3): The part of a Data Frame that contains the sampled data corresponding to the time-tag in the Data Frame Header.

Data Frame (Section 3): The basic VDIF data structure, containing a Data Frame Header with time-tag and data-identification information, followed by a Data Array containing the actual corresponding time-sampled data from one or more data channels, as shown in Figure 1.

Data Group (see Data Stream)

Data Frame Header (Section 3): The part of a Data Frame with time-tag and data-identification information and, optionally, with Extended User Data.

Data Segment (Section 3): For purposes of VDIF, a “Data Segment” is defined as a Data Stream with a well-defined beginning and end. For real-time network data transfer, a Data Segment normally starts at the first received packet of a VDIF Data Stream and ends at the termination of that Data Stream. For data captured onto a VDIF-format disk file, a single disk file constitutes a Data Segment. A Data Segment may contain any number of physical observations (often called “scans”).

Data Stream (Section 3): An intermixed data flow of one or more Data Threads, where each Data Thread consists contains a unique Thread ID

- ‘Simple’ VDIF Data Stream (Section 12.1): A Data Stream limited to 1) one or more single-channel Data Threads, each with the same sample rate, #bits/sample, and data type (‘real’ or ‘complex’), or 2) one or more multi-channel Data Threads, each with the same number of channels, sample rate, #bits/sample, and data type (‘real’ or complex’).
- ‘Compound’ VDIF Data Stream (Section 12.2): A Data Stream containing two or more ‘simple’ VDIF Data Streams. Each constituent ‘simple’ Data Stream is identified by a Base Thread ID: the number corresponding to the lowest-numbered Thread ID of a constituent ‘simple’ Data Stream. Knowledge of the set of Base Thread IDs for a ‘compound’ Data Stream allows easy association of any particular Data Thread with its corresponding constituent ‘simple’ Data Stream (known as Data Group).

Data Thread (Section 3): A Data Thread consists of a time sequence of Data Frames with the same numerical Thread ID (embedded in the Data Frame Header).

Extended User Data (Section 6): Part of the Data Frame Header with unspecified format which may be optionally used for user-generated data.

Reference Epoch (Section 6): The epoch for which the second counter in the Data Frame Header is identically zero.

VDIF (Section 1): Acronym for VLBI Data Interchange Format

VDIF Format Designator (Sections 12.1 and 12.2): A short-hand ASCII descriptor for the characteristics of a particular VDIF Data Stream

## Addendum 2: VDIF Hardware/Firmware Design Considerations

Although not part of the formal VDIF specification, the following notes are offered as suggestions to be kept in mind when designing VDIF-compatible systems:

1. The VDIF second tick is normally set by a *one-time* synchronization with a high-quality station tick (typically from H-maser or GPS), and thereafter is independently generated by reference only to the station frequency standard (or a signal that is phase-locked to the station frequency standard, such as the sampler clock). It is suggested that synchronization of the VDIF second tick be done prior to, and independently of, the VDIF clock setting, so that the VDIF clock setting can be adjusted, if necessary, without a risk of changing the epoch of the VDIF second tick.
2. The VDIF clock setting is typically done by arming the VDIF clock to be set to a user-specified value (UTC at next second tick) at the occurrence of the 'next VDIF second tick'. Following its initial setting, the VDIF clock increments the VDIF second count (carried in Word 0 of each Data Frame Header) on every subsequent second tick. The VDIF second counter should rollover back to zero after reaching a value of  $2^{28}-1$ .
3. As a double-check on the correct setting of the VDIF clock, it is suggested that each station periodically record (in the experiment log file) the correspondence between station UTC time and the corresponding VDIF time code (read from the hardware/firmware VDIF clock). This will allow correlator personnel to double-check the VDIF clock setting if necessary. When performing this check, care must be taken to ensure that the both recorded times refer to the same second. One simple procedure is for the VDIF hardware/firmware to delay response to a VDIF clock-reading request until just after the next-occurring VDIF second tick (responding with the just-updated VDIF time code), after which the corresponding station time is immediately read.
4. The user must be able to infer the Data Array format from the specification of the #channels and #bits/sample in the Data Frame Header. This will work only if the Data Array is strictly formatted according to the Data Array format specifications in this document.
5. At a minimum, the user must be able to specify the Data Frame length and Station ID. Some systems may require additional flexibility in allowing the user to specify additional parameters.
6. Users are strongly encouraged to adopt an operating mode of one channel per Data Thread, which the hardware/firmware should support. This mode of operation is most compatible with the emerging generation of software-based correlators, and will result in the most efficient operation when used in association with such correlator systems.





**IVS Coordination**

**IVS Coordination**





# Coordinating Center Report

*Dirk Behrend*

## Abstract

This report summarizes the activities of the IVS Coordinating Center during the year 2009 and forecasts activities planned for the year 2010.

## 1. Coordinating Center Operation

The IVS Coordinating Center is based at the Goddard Space Flight Center and is operated by NEOS (National Earth Orientation Service), a joint effort for VLBI by the U.S. Naval Observatory and the NASA Goddard Space Flight Center.

The mission of the Coordinating Center is to provide communications and information for the IVS community and the greater scientific community and to coordinate the day-to-day and long-term activities of IVS.

The Web server for the Coordinating Center is provided by Goddard. The address is

<http://ivscc.gsfc.nasa.gov>

## 2. Activities during 2009

During the period from January through December 2009, the Coordinating Center supported the following IVS activities:

- Directing Board support: Coordinated, with local committees, two IVS Directing Board meetings, in Bordeaux, France (March 2009) and Buenos Aires, Argentina (August 2009). Notes from each meeting were published on the IVS Web site.
- Communications support: Maintained the Web pages, e-mail lists, and Web-based mail archive files. Generated analysis reports and included them into the 24-hour session Web pages. Maintained Intensive session Web pages.
- Publications: Published the 2008 Annual Report in spring/summer 2009. Published three editions of the IVS Newsletter in April, August, and December, 2009. All publications are available electronically as well as in print form.
- 2009 Master Schedule: Generated and maintained the master observing schedule for 2009. Coordinated VLBI resources for observing time, correlator usage, and disk modules. Coordinated the usage of Mark 5 systems at IVS stations and efficient deployment of disk modules. Coordinated the Very Large Astrometry Session in support of the International Year of Astronomy 2009 (IYA09).
- 2010 Master Schedule: Generated the proposed master schedule for 2010 and received approval from the Observing Program Committee.
- Meetings: Coordinated, with the Local Committee, the fifth IVS Technical Operations Workshop, held at Haystack Observatory in April 2009. Chaired the Program Committee for the meeting. Coordinated, with the Local Committee, the sixth IVS General Meeting, to be held

in Hobart, Tasmania, Australia in February 2010. Chaired the Program Committee for the meeting.

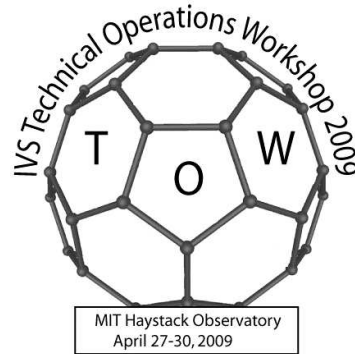

Figure 1. Logo of the fifth IVS Technical Operations Workshop held at Haystack Observatory in April 2009. More information about the workshop can be found at <http://ivscg.gsfc.nasa.gov/meetings/tow2009/>.

- Observing Program Committee (OPC): Coordinated meetings of the OPC to monitor the observing program, review problems and issues, and discuss changes.
- VLBI2010 Committee (V2C): Participated in the work of the V2C. Co-edited and published the Progress Report of the V2C as a NASA Technical Memorandum with the title “Design Aspects of the VLBI2010 System”.



Figure 2. The cover design of the Progress Report of the V2C, which was published as NASA Technical Memorandum TM-2009-214180 in June 2009. An online version of the report is available at <ftp://ivscg.gsfc.nasa.gov/pub/misc/V2C/TM-2009-214180.pdf>.

### 3. Tenth Anniversary Celebration

On March 1, 2009 the IVS completed its first decade of being a service for geodetic and astrometric VLBI. For that, a special event was held on March 25, 2009 in Bordeaux, France to celebrate the 10th Anniversary. The Coordinating Center was involved in organizing the program of a commemorative symposium and assisted the local organizers from Bordeaux Observatory, who did an excellent job of making the whole event a very memorable one, with the logistical arrangements. The symposium was held in the Salle Agora of Université Bordeaux 1. This chapel-converted-to-ballroom gave the event the proper ambience. The event was broadcast live over the Internet. A recording of the various presentations is available at <http://canalc2.u-strasbg.fr/video.asp?idvideo=8558>. Pictures are available at the URL <http://www.u-bordeaux1.fr/vlbi2009>.



Figure 3. Participants at the festivities for the IVS 10th Anniversary in Bordeaux, France.

### 4. IYA09 Astrometry Session

The Coordinating Center coordinated the Very Large Astrometry Session IYA09 as an activity for the International Year of Astronomy 2009. A call for participation was prepared and distributed, resulting in a positive response from 25 stations. Following feasibility discussions with the VLBA, the Coordinating Center submitted a “Target of Opportunity” proposal to the VLBA, and it was accepted. Hence, the total number of IYA09 stations rose to 35. The overall observational network is shown in Figure 4.

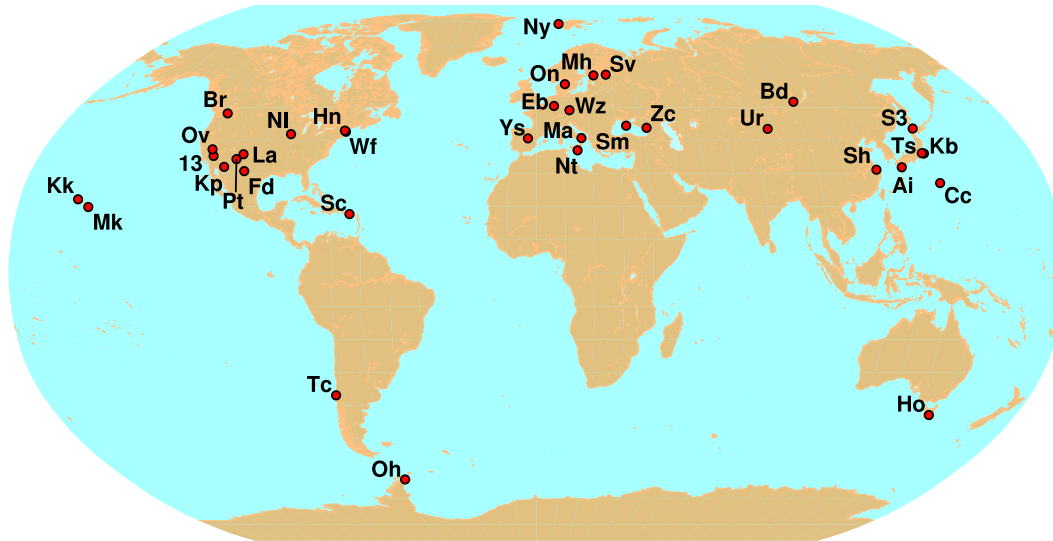

Figure 4. Observational network of the IYA09 Very Large Astrometry Session. From the original 35-station network, Svetloe had to drop out due to mechanical problems. DSS13 had a problem with one of the two X-band channels during the observations; it is likely that it will have to be dropped during the correlation.

The Coordinating Center supported the Task Force for the IYA09, which was established by the IVS Directing Board at its 20th meeting in Penticton, BC, Canada in September 2008. The task force consisted of Patrick Charlot (chair), Dirk Behrend (co-chair), Axel Nothnagel, Hayo Hase, and Oleg Titov. The scientific and outreach goals of the IYA09 session were determined to be the following:

- Scientific goals:
  - strengthen the ICRF2 by observing as many ICRF2 defining sources as possible in one single session (ultimately 243 out of 295);
  - provide the arc lengths between all sources without relying on source overlaps.
- Outreach activities:
  - press releases through the IYA2009 organization (AGU), IVS, and other organizations;
  - news coverage in regional and national media;
  - open doors at stations;
  - real time broadcast of the progress of the session via the Internet.

On the IVS Web site a dedicated Web page (<http://ivscc.gsfc.nasa.gov/program/iya09/>) serves as a repository of information for the IYA09 session. In addition, Bordeaux Observatory developed a dynamic Web page where the interested user could observe the progress of the IYA09 session in real time. Figure 5 shows a snapshot of the Web page taken during the observation of the session.

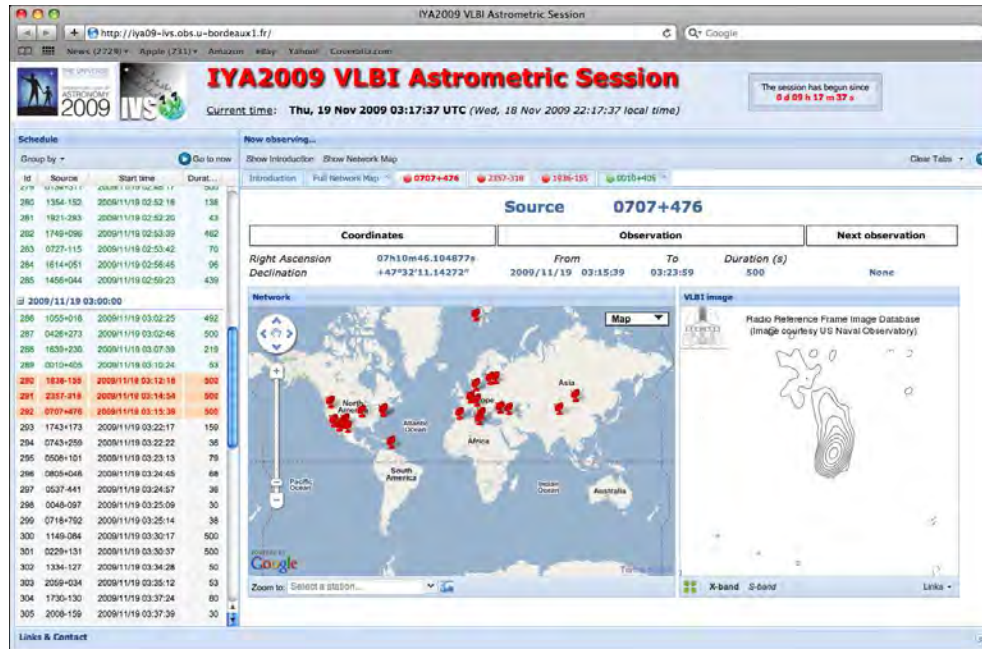

Figure 5. Snapshot of the dynamical Web page hosted at Bordeaux Observatory and taken during the observation of the IYA09 session. The Web page depicts the observational network of a particular scan and an image of the observed radio source. Further links led to information about the stations and station Webcams.

### 5. Staff

The staff of the Coordinating Center is drawn from individuals who work at Goddard. The staff and their responsibilities are listed in Table 1.

Table 1. IVS Coordinating Center staff.

Name	Title	Responsibilities
Dirk Behrend	Director	Web site and e-mail system maintenance, Directing Board support, meetings, publications, session Web page monitoring
Cynthia Thomas	Operation Manager	Master schedules (current year), resource management and monitoring, meeting and travel support, special sessions
Frank Gomez	Web Manager	Web server administration, mail system maintenance, data center support, session processing scripts, mirror site liaison
Karen Baver	General Programmer and Editor	Publication processing programs, LaTeX support and editing, session Web page support and scripts

## 6. Plans for 2010

The Coordinating Center plans for 2010 include the following:

- Maintain IVS Web site and e-mail system.
- Publish the 2009 Annual Report (this volume).
- Coordinate, with the local committee, the sixth IVS General Meeting to be held in Hobart, Tasmania, Australia in February 2010.
- Publish the 2010 General Meeting Proceedings.
- Support Directing Board meetings in 2010.
- Coordinate the 2010 master observing schedules and IVS resources.
- Publish Newsletter issues in April, August, and December.

# Analysis Coordinator Report

*A. Nothnagel, S. Böckmann, T. Artz*

## Abstract

IVS analysis coordination issues in 2009 are reported here. Routine EOP combinations on the basis of datum-free normal equations have been continued. The input of the IVS to ITRF2008 was generated at the IVS Analysis Coordinator's office carrying out the combination in a similar way as the routine EOP combinations. However, the number of input series has been increased to nine, permitting a rigorous quality assessment.

## 1. General Issues

The "Tenth IVS Analysis Workshop" was hosted by the Laboratoire d'Astrophysique de Bordeaux, France, in the building of the Cap Sciences, on March 26, 2009, in connection with the Nineteenth Meeting of the European VLBI Group for Geodesy and Astrometry. As in previous meetings, the coordination of IVS routine data analysis was discussed, as well as developments for improving geodetic and astrometric data analysis in general.

An important item for the years to come will certainly be how to maintain and improve the storage and handling of auxiliary data. Today, the only auxiliary data registered routinely is meteorological and cable calibration data. At most observatories, readings of these data types are triggered by the Field System and storing is done in session-wise log files. For past applications, this procedure has certainly been sufficient but the requirements are growing. A simple example is that ambient temperatures of about two hours before a VLBI session starts are needed for modeling of thermal expansion at the start of the session due to a time lag of about two hours for standard steel constructions. In addition to weather and cable cal data, further information can be used for a better modeling of environmental effects such as invar rod readings of the telescope tower height, ground water table heights and so on.

For this purpose, it is best to start setting up a seamless or continuous data storage scheme which is not limited by VLBI session boundaries and stores the data in separate files. A group of specialists has been gathered to develop a suitable scheme including the other space-geodetic techniques as well.

Concluding the workshop, Alessandra Bertarini and Brian Corey contributed a valuable tutorial on correlator operations. They presented a description of the data path from the correlation process to analysis including a description of Fourfit (fringe fitting) plots.

## 2. IVS Operational Data Analysis and Combination

The combination process for the two IVS EOP series (rapid and quarterly solutions) has been continued exclusively on the basis of datum-free normal equations in SINEX format. In 2009, six IVS Analysis Centers (BKG, DGFI, GSFC, IAA, OPA, and USNO) contributed to the IVS combined products by providing input in the correct format. The combination strategy is described in detail in [2].

The rapid solutions contain only R1 and R4 sessions, and new data points are added twice a week as soon as the SINEX files of at least five IVS Analysis Centers are available. The SINEX file submissions should not be later than 48 hours after the correlation is completed. A Web page

([http://vlbi.geod.uni-bonn.de/IVS-AC/data/timeliness\\_2.html](http://vlbi.geod.uni-bonn.de/IVS-AC/data/timeliness_2.html)) which states the timeliness of the latest submissions of the R1 and R4 sessions is automatically updated. As can be seen on this Web page, the timeliness requirement is still exceeded too often for various reasons in logistics and personnel.

For the quarterly solution, updated every three months, almost all available data of 24-hour sessions from 1984 onwards are used. Since this series is designed for EOP determinations, those sessions which are observed with networks of limited extension or which are scheduled for a different purpose such as radio source monitoring are excluded.

From October 1, 2009, the operational combination has been taken over by the IVS Combination Center at the German Bundesamt für Kartographie und Geodäsie (BKG) in Frankfurt a.M.. The transition has been smooth, and no further complications have been reported.

### 3. Generation of Input to ITRF2008

In late 2008, the IERS ITRF Product Center issued a call for contributions to the next realization of the ITRS, ITRF2008. The official contribution of the IVS to ITRF2008 was generated at the IVS Analysis Coordinator's office. It consists of session-wise datum-free normal equations which are the result of a combination of individual series of session-wise datum-free normal equations provided by seven IVS ACs (BKG, DGFI, GSFC, IGGB, OPA, SHA, and USNO). All these individual series are completely reprocessed following homogeneous analysis options according to the IERS Conventions 2003 [4] and IVS Analysis Conventions [5].

Altogether, nine IVS ACs analyzed the full history of VLBI observations with four different software packages. Unfortunately, the contributions of two ACs, IAA and GA, had to be excluded from the combination process. In the case of the IAA contribution, a scale offset of 1.5 ppb was detected. Most probably, this offset can be related to the relativistic model used in the QUASAR software which did not comply with the model recommended in the IERS Conventions 2003. The GA solution showed large inconsistencies with respect to all other contributions when looking at the station position time series, the TRF solution, and the long term EOP series. However, the direct results from the OCCAM(LSC) software are quite reasonable. Thus, most likely, errors in the analysis chain—i.e., in the generation of the normal equations written into SINEX—occurred.

Based on the experience gathered since the combination efforts for ITRF2005, the consistency of the individual VLBI solutions has improved considerably. The agreement in terms of the WRMS of the terrestrial reference frame (TRF) horizontal components is 1 mm and of the height component is 2 mm. Comparisons between ITRF2005 and the combined TRF solution for ITRF2008 yielded systematic height differences of up to 5 mm with a zonal signature. These differences can be related to a pole tide correction referenced to a zero mean pole used by four of five IVS ACs in the ITRF2005 contribution instead of a linear mean pole path as recommended in the IERS Conventions. Periodic annual variations in scale are reduced considerably from 2.7 mm to 1.7 mm due to the correction for thermal expansion of the radio telescopes. A detailed description of the IVS input to ITRF2005 can be found in [1] and [3].

### 4. Thermal Expansion of Radio Telescopes

Further details of radio telescopes have been collected in the antenna-info file under <http://vlbi.geod.uni-bonn.de/IVS-AC/Conventions>.



## 5. Personnel

Table 1. Personnel at the IVS Analysis Coordinator's office

Axel Nothnagel	+49-228-733574	nothnagel@uni-bonn.de
Sarah Böckmann	+49-228-733563	boeckmann@uni-bonn.de
Thomas Artz	+49-228-733563	thomas.artz@uni-bonn.de

## References

- [1] Böckmann S., Artz T., Nothnagel A. (2009) IVS' contribution to ITRF2008. In: Proceedings of the 19th European VLBI for Geodesy and Astrometry Working Meeting; G. Bourda, P. Charlot and A. Collioud (eds.); 102 - 106, Laboratoire d'Astrophysique de Bordeaux, Bordeaux
- [2] Böckmann S., Artz T., Nothnagel A., Tesmer V. (2010) International VLBI Service for Geodesy and Astrometry: EOP combination methodology and quality of the combined products, *J. of Geophysical Research*, doi:10.1029/2009JB006465, in press
- [3] Böckmann S., Artz T., Nothnagel A., (2010) VLBI terrestrial reference frame contributions to ITRF2008, *J. of Geodesy*, doi:10.1007/s00190-009-0357-7, in press
- [4] McCarthy D., Petit G. (2004) *IERS Conventions (2003)*. Verlag des Bundesamtes für Kartographie und Geodäsie, Frankfurt am Main, (available electronically at <http://www.iers.org/documents/publications/tn/tn32/tn32.pdf>)
- [5] Nothnagel A. (2009) Conventions on thermal expansion modelling of radio telescopes for geodetic and astrometric VLBI. *J. Geod* 83(8):787–792, doi:10.1007/s00190-008-0284-z

# Network Coordinator Report

*Ed Himwich*

## Abstract

This report includes an assessment of the network performance in terms of lost observing time for the 2009 calendar year. Overall, the observing time loss was about 21.5%, an increase of about 6.4% from what was reported for the previous year. It should be noted that most of this increase may be due to changes in the accounting methods. The number of experiments scheduled was about 15% fewer than the previous year. However the number of stations per session increased from about 7.2 to 7.9, resulting in only about a 6% reduction in the number of station observing days. A table of relative incidence of problems with various subsystems is presented. The most significant identified causes of loss were antenna reliability (accounting for about 29.4% of losses), receiver problems (18.6%), and miscellaneous problems (15.3%) including scheduling conflicts, power failures, and weather. Unidentified problems accounted for about 14.2% of the loss. There are prospects for Korea, India, and Saudi Arabia to start contributing to IVS. New antennas have been or are being built by Australia, New Zealand, and the USA.

## 1. Network Performance

This network performance report is based on correlator reports for experiments in calendar year 2009. This report includes results for the 135 24-hour experiments that had detailed correlator reports available as of April 1, 2010. Results for 22 experiments were omitted because either they were correlated at the VLBA, they have not been correlated yet, or correlation reports were not available on the IVS data centers. Experiments processed at the VLBA correlator were omitted because the information provided is not as detailed as from Mark IV correlators. The experiments that have not been correlated or do not have correlator reports available yet include all the OHIG experiments, astrometry experiments that will be correlated in Australia, two T2s, and IYA09. In summary, roughly 86% of the scheduled experiments for 2009 are included in this report. That is similar to the coverage of reports for previous years.

An important point to understand is that in this report the network performance is expressed in terms of lost observing time. This is straightforward in cases where the loss occurred because operations were interrupted or missed. However, in other cases, it is more complicated to calculate. To handle this, a non-observing time loss is typically converted into an equivalent lost observing time by expressing it as an approximate equivalent number of recorded bits lost. As an example, a warm receiver will greatly reduce the sensitivity of a telescope. The resulting performance will be in some sense equivalent to the station having a cold receiver but observing for (typically) only one-third of the nominal time and therefore recording the equivalent of only one-third of the expected bits. In a similar fashion, poor pointing can be converted into an equivalent lost sensitivity and then equivalent fraction of lost bits. Poor recordings are simply expressed as the fraction of total recorded bits lost.

Using correlator reports, an attempt was made to determine how much observing time was lost at each station and why. This was not always straightforward to do. Sometimes the correlator notes do not indicate that a station had a particular problem, while the quality code summary indicates a significant loss. Reconstructing which station or stations had problems—and why—in these circumstances does not always yield accurate results. Another problem was that it is hard to determine how much RFI affected the data unless one or more channels were removed and that

eliminated the problem. It can also be difficult to distinguish between BBC and RFI problems. For individual station days, the results should probably not be assumed to be accurate at better than the 5% level.

The results here should not be viewed as an absolute evaluation of the quality of each station's performance. As mentioned above, the results themselves are only approximate. In addition, some problems are beyond the control of the station, such as weather and power failures. Instead the results should be viewed in aggregate as an overall evaluation of what percentage of the observing time the network is collecting successfully. Development of the overall result is organized around individual station performance, but the results for individual stations do not necessarily reflect the quality of operations at that station.

Since stations typically observe with more than one other station at a time, the average lost observing time per station is not equal to the overall average loss of VLBI data. Under some simplifying assumptions, the average loss of VLBI data is roughly about twice the average loss of observing time. This approximation is described in the Network Coordinator's section of the IVS 2001 Annual Report.

For the 135 experiments from 2009 examined here, there were 1,051 station days or about 7.9 stations per experiment on average. This compares to 155 experiments considered in the previous year's report for 2008, which included 1,121 station days with 7.2 stations per experiment. Of the station days for 2009 about 21.5% (or about 226 days) of the observing time was lost. For comparison to reports from earlier years, please see Table 1.

Table 1. Lost observing time

<b>Year</b>	<b>Percentage</b>
1999-2000*	11.8
2001	11.6
2002	12.2
2003	14.4
2004	12.5
2005	14.4
2006	13.6
2007	11.4
2008	15.1
2009	21.5

\* The percentage applies to a subset of the 1999-2000 experiments.

The lost observing time for 2009 was significantly more than for all other previous years. This may be to some extent an artifact due to a change in the way the master files are handled starting in 2009 compared to previous years. Beginning in 2009, stations that were unable to observe due to a long term problem were removed from the master file for individual experiments only if a suitable replacement was found. If no replacement was available, they were included as "failed" stations in the master file. This change was made so that the loss statistics would more accurately reflect losses in allocated observing time. For 2009, this primarily affected Fortaleza, which had an antenna failure, and Westford, which had several scheduling conflicts. The station days lost

counted in this way nearly account for the increase in the percentage of station days lost. Looking at it in a different way, some of the apparent increase may be due to the fact that some losses in 2008 and previous years were not tracked in this more complete way. If the newer method had been used for 2008, it would have increased the percentage of data lost by a few percent, just for the effect of HartRAO (the most significant case that year). It is difficult to assess the overall effect of this change precisely because it would not be practical to reconstruct the changes that would have been made to the master files over a year ago. In the end, it seems safe to say that the data loss for stations without long term disabling problems is about the same for 2009 as it was for previous years. In addition, it appears that the more strictly accounted loss of observing time is somewhat higher than the 11-15% seen in previous years. The results for 2010 will provide additional information that may help to assess the variation in this statistic.

The loss of HartRAO, due to antenna problems, is not included in these results since it was never scheduled for 2009. The absence of HartRAO largely accounts for the reduction in the number of reported station days observed in 2009 (1,051) compared to 2008 (1,121). If HartRAO had been included in these results, the overall loss would have been about 25%.

An assessment of each station's performance is not provided in this report. While individual station information was presented in some of the previous years, this practice seemed to be counter-productive. Although many caveats were provided to discourage people from assigning too much significance to the results, there was feedback that suggested that the results were being over-interpreted. Additionally, some stations reported that their funding could be placed in jeopardy if their performance appeared bad even if it was for reasons beyond their control. Last and not least, there seemed to be some interest in attempting to "game" the analysis methods to improve the individual results. Consequently, only summary results are presented here. Detailed results are presented to the IVS Directing Board. Each station can receive the results for their station by contacting the Network Coordinator (Ed.Himwich@nasa.gov).

For the purposes of this report, the stations were divided into two categories: **large N**: those that were included in 20 or more network experiments among those analyzed here, and **small N**: those in 16 or fewer experiments. (No stations were in 17-19 experiments.) The distinction between these two groups was made on the assumption that the results would be more meaningful for the stations with more experiments. The average observing time loss from the large N group was much smaller than the average from the small N group, 20.5% versus 28.8%. The losses for both groups were larger than in previous years. There are many fewer station days in the small N group than the large N group—120 versus 931—so the large N group is dominant in determining the overall performance.

There are 15 stations in the large N group. Eight stations observed in 58 or more experiments. Of the 15, six stations successfully collected data for approximately 90% or more of their expected observing time. Five more stations collected 80% or more of the time. Four more stations collected data for more than 60% of their observing time. Fortaleza, due to its long term antenna problem, collected only about 40% of its scheduled data. Westford, due to its scheduling conflicts, collected only about 63% of its scheduled data. These statistics, with the exception of the losses for Fortaleza and Westford, are only slightly worse than last year's.

There are 20 stations in the small N group. The range of lost observing time for stations in this category was 1%-100%. The median loss rate was about 42%, much worse than last year. This was largely due to schedule conflicts at DSN stations and to weather and other problems at VLBA stations.

The losses were also analyzed by sub-system for each station. Individual stations can contact the Network Coordinator (Ed.Himwich@nasa.gov) for the sub-system breakdown (and overall loss) for their station. A summary of the losses by sub-system (category) for the entire network is presented in Table 2. This table includes results since 2003 sorted by decreasing loss in 2009.

Table 2. Percentage of observing time lost by sub-system

Sub-System	2009	2008	2007	2006	2005	2004	2003
Antenna	29.4	19.2	34.6	19.0	24.4	32.9	17.8
Receiver	18.6	13.8	14.9	20.8	24.2	18.0	25.2
Miscellaneous	15.3	12.8	7.6	18.0	8.0	8.0	6.0
Unknown	14.2	17.7	14.9	4.0	3.3	10.1	12.6
Rack	6.6	8.7	11.4	16.3	5.1	6.8	5.0
RFI	5.9	14.8	10.4	11.6	6.2	5.0	9.3
Shipping	4.0	5.4	1.0	0.0	0.2	1.4	6.1
Recorder	2.9	4.1	4.6	3.3	8.9	11.1	10.9
Clock	1.9	0.5	0.3	4.9	14.5	0.5	3.4
Operations	1.2	2.3	0.0	2.0	4.7	6.1	3.6
Software	0.1	0.1	0.4	0.1	0.5	0.1	0.1

The categories in Table 2 are rather broad and require some explanation, which is given below.

**Antenna** This category includes all antenna problems including mis-pointing, antenna control computer failures, non-operation due to wind, and mechanical breakdowns of the antenna.

**Clock** This category includes situations where correlation was impossible because the clock offset either was not provided or was wrong, leading to “no fringes”. Maser problems and coherence problems that could be attributed to the Maser were also included in this category. Phase instabilities reported for Kokee were included in this category.

**Miscellaneous** This category includes several small problems that do not fit into other categories, mostly problems beyond the control of the stations, such as power, (non-wind) weather, cables, scheduling conflicts at the stations, and errors in the observing schedule provided by the Operation Centers. For 2006 and 2007, this category also includes errors due to tape operations at the stations that were forced to use tape because either they didn’t have a disk recording system or they did not have enough media. All tape operations have since ceased. This category is dominated by power, weather, and scheduling conflict issues.

**Operations** This category includes all operational errors, such as DRUDG-ing the wrong schedule, starting late because of shift problems, operator (as opposed to equipment) problems changing recording media, and other problems.

**Rack** This category includes all failures that could be attributed to the rack (DAS) including the formatter and BBCs. There is some difficulty in distinguishing BBC and RFI problems in the correlator reports, so that some losses are probably mis-assigned between these categories.

**Receiver** This category includes all problems related to the receiver including outright failure, loss of sensitivity because the cryogenics failed, design problems that impact the sensitivity,

LO failure, and loss of coherence that was due to LO problems. In addition, for lack of a more clearly accurate choice, loss of sensitivity due to upper X band Tsys and roll-off problems were assigned to this category.

**Recorder** This category includes problems associated with data recording systems. Starting with 2006, no problems associated with tape operations are included in this category.

**RFI** This category includes all losses directly attributable to interference including all cases of amplitude variations in individual channels, particularly at S-band. There is some difficulty in distinguishing BBC and RFI problems in the correlator reports, so that some losses are probably mis-assigned between these categories.

**Shipping** This category includes all observing time lost because the media were lost in shipping or held up in customs or because problems with electronic transfer prevented the data from being correlated with the rest of the experiment's data.

**Software** This category includes all instances of software problems causing observing time to be lost. This includes crashes of the Field System, crashes of the local station software, and errors in files generated by DRUDG.

**Unknown** This category is a special category for cases where the correlator did not state the cause of the loss and it was not possible to determine the cause with a reasonable amount of effort.

Due to the significant losses due to antenna problems, the combined losses due to the "Antenna" (29.4%) and "Receiver" (18.6%) sub-systems was about 48%, up from last year's unusually low level (33%), but more like the typical value seen in prior years. This is primarily due to the significant losses due to Fortaleza's antenna problems. (Please note that the effect of HartRAO not being available for all of 2009 is not represented here. If it were included, it would increase the overall losses by about 4% and increase the antenna related losses to about 42%.) Stations that had significant antenna problems (excepting HartRAO) include Seshan, Fortaleza, and Svetloe. HartRAO is expected to return to limited operation by mid-2010. Fortaleza is not expected to return to operation until late 2010 at the earliest.

Stations with significant receiver problems include Ny-Ålesund, TIGO, and Matera. The most significant problems were LO and cryogenic failures. The harsh conditions at Ny-Ålesund can prevent timely receiver repair thus creating extensive losses for otherwise minor problems.

The "Unknown" category loss is somewhat smaller than last year's value and about the same as the year before that. In the years before those years, the level was lower. This may be a reporting problem due to the correlators being under increasing resource pressure and therefore not being free to chase down the cause of every particular problem. It is also extremely time consuming to do this when constructing this report. The impression created by the pattern of unknown losses does not suggest that it is due to any particular sub-system.

The "Miscellaneous" category loss is larger than last year and worse than the results in almost all other years. This year, in addition to weather and power related losses, some experiments were missed due to scheduling conflicts with other users of the stations. This was particularly true at Westford. The losses at Westford due to conflicts represents more than half of the loss in this category.

The "Rack" category loss was smaller this year and well below its peak levels a few years ago. In those years, losses were being suffered by Sheshan due to their rack not being fully populated

with modules. This situation was corrected by the loan of modules by NASA. There has been some improvement in the BBC situation at Zelenchukskaya and Badary as well. Some losses may be mis-assigned between this category and the RFI category due to the difficulty in distinguishing BBC and RFI problems in the correlator reports.

The “RFI” category loss level is significantly lower than in previous years. This appears to be due primarily to a decrease in the RFI losses attributed to the three Russian stations: Svetloe, Zelenchukskaya, and Badary. In the case of Svetloe it seems that the increase in observing time lost to antenna and Maser problems reduced the opportunity for the station to suffer RFI problems. There is no clear explanation for why the other two stations suffered fewer RFI losses. Although RFI and BBC problems are sometimes confused, there was not enough increase in BBC attributed problems to explain the reduction in RFI problems at these stations (and actually, there was a decrease). It may be that the stations made changes to improve their reduction of RFI and/or that the correlators have been more sophisticated in their treatment of RFI and do not delete entire channels as often. Another possible contributing factor is that these stations have made improvements to their systems that eliminated BBC related losses that were being incorrectly identified as RFI. WACO confirmed that they noticed general improvements in the data from these stations, particularly for Badary (K. Kingham, USNO, personal communication), that are consistent with this interpretation. If this is correct, then the level of RFI seen has not suffered the apparent increase over the last few years that had been reported. It does however continue to be a significant source of loss.

The “Clock” category increased somewhat from last year. This appeared to be primarily due to a Maser problem at Svetloe.

The “Recorder” category decreased from the previous year and may represent more successful disk operations and fewer disk failures.

The “Shipping” category continued at nearly the same high level as had been seen last year. Presumably this increase over previous lower levels is due to the notable customs problems with disks that have been occurring recently.

In summary, the biggest single increase in losses in 2009 was due to antenna problems. There was also a significant increase in losses due to receiver problems. Unfortunately due to aging hardware we can expect these losses to continue, although we can hope that they will not be at quite such a high level, until hardware upgrades such as VLBI2010 are implemented. A bright spot is that RFI losses appear to be down, and this appears to be due to the fact that in previous years, some problems thought to be RFI related were not, and those problems have been reduced. We can however expect that RFI problems will continue while we use S- and X-band primarily.

## 2. New Stations

There are prospects for new stations on several fronts. In New Zealand, the station Warkworth has its antenna in place. In Australia, the new 12-m antenna at Hobart has been completed. New antennas at Katherine and Yarragadee are under construction. It is expected that all four of these antennas will start observing for IVS in 2010.

At GSFC in the USA, a new 12-m antenna will be erected in 2010. While this antenna is primarily for use in development of the VLBI2010 systems, it is expected that it will eventually join the network for regular observing. At Arecibo in Puerto Rico a new 12-m antenna has been erected and may be used for geodetic observing.

At Wettzell in Germany, construction of the new Twin Telescope Wettzell (TTW) for VLBI2010 has commenced. In Spain/Portugal, the RAEGE (Atlantic Network of Geodynamical and Fundamental Stations) project aims to establish a network of four fundamental geodetic stations including radio telescopes that will fulfill the VLBI2010 specifications: Yebes (1), Canary Islands (1), and Azores (2). In Norway, the Norwegian Mapping Agency (NMA) has applied for a project to establish a fundamental station at Ny-Ålesund, which will include a twin telescope of the Wettzell type.

In Russia, an effort is underway to get 12-m VLBI2010 antennas at some of the QUASAR network sites.

Korea is planning to build one antenna primarily for geodesy (Korea VLBI for Geodesy, KVG) at Sejong with construction to be completed in 2011. There is also interest in using the Korean VLBI Network (KVN), which will consist of three stations intended primarily for astronomy, for geodesy. There is interest in India in building a network of four telescopes that would be useful for geodesy. Saudi Arabia is investigating having a combined geodetic observatory, which would presumably include a VLBI antenna.

Many of these antennas may become available for use in the next few years. Efforts are being made to ensure that these antennas will be compatible with VLBI2010.



# IVS Technology Coordinator Report

*Alan Whitney*

## Abstract

The efforts of the Technology Coordinator in 2009 include the following areas: 1) support of work to implement the new VLBI2010 system, 2) continued development and deployment of e-VLBI, 3) continuing development of global VLBI standards, and 4) digital-backend compatibility testing. We will briefly describe each of these activities.

## 1. VLBI2010 Progress

Progress continues towards the goal of a next-generation VLBI2010 system. Much more detailed information about VLBI2010 development is presented elsewhere in this report; here we briefly report some of the highlights.

### 1.1. Development of the VLBI2010 Broadband System

The VLBI2010 testbed using the 18-m antenna at Westford, MA and the 5-m MV3 antenna at NASA/GSFC continued to be developed. Among the highlights of 2009 are:

1. Development and checkout of a phase-calibration system for the VLBI2010 system.
2. Nearing the completion of RDBE, a next-generation digital-backend based on the ROACH FPGA-based board which accepts up to four 500 MHz-wide IFs and channelizes each into fifteen adjacent 32 MHz-wide channels using polyphase filter band (PFB) technology, although only every other channel is recorded. In the full-up demo system, four dual-polarization IFs of 500 MHz width each are processed through eight PFBs, each IF creating 1 Gbps of data for a total of 8 Gbps.
3. Nearing the completion of the 4 Gbps Mark 5C+ VLBI data system. The current Mark 5B+ systems being used for VLBI2010 experiments will be replaced with Mark 5C in 2010.
4. Development of the new 'eleven' broadband feed for VLBI2010 is currently underway at Chalmers University of Technology in Sweden.
5. 12-meter antennas from Patriot Antenna Systems have been installed in New Zealand and Australia, and one has been ordered for installation at NASA/GSFC in Greenbelt, MD in early 2010. Development of 13-m antenna systems continues under the leadership of Wettzell.
6. More than two dozen separate VLBI2010 data taking sessions were undertaken during 2009, a number of them 24-hour sessions. Typically, data were recorded onto four Mark 5B+ units at each station, for an aggregate data rate of 8 Gbps/station. Processing was done at reduced speed on the Mark IV correlator.

### 1.2. VLBI2010 Workshop

More than 50 people attended a highly successful VLBI2010 Workshop on Future Radio Frequencies and Feeds held 18-20 March 2009 near Wettzell, Germany. Presentations and discussions were included on the following topics:

- broadband observation strategy
- feed issues
- polarization
- broadband receiver design
- radio frequency interference (RFI)
- geodetic ties between VLBI and other techniques (GNSS, SLR, etc.)
- conclusions and recommendations to the IVS Directing Board

This VLBI2010 workshop was followed by a V2C meeting which focused on digital baseband converters and software correlators. As a result of these meetings, the following recommendations were made to the IVS Board and are now under consideration:

- The initial implementation of the VLBI2010 system needs to be capable of observing the broadband range of 2.2 to  $\sim 14$  GHz.
- The VLBI2010 system needs to be capable of S/X operation.
- The antenna should allow for a possible future inclusion of Ka-band (32 GHz) operation.
- The complete end-to-end operation of the VLBI2010 system should be demonstrated in a campaign in early 2012. As many antennas as possible should participate.
- A plan should be established for the transition from the legacy S/X system to the VLBI2010 broadband delay system. Such a transition plan can be beneficial for obtaining future funding and will support a timely changeover.



Figure 1. Attendees of the VLBI2010 Workshop on Future Radio Frequencies and Feeds held near Wettzell, Germany

## 2. e-VLBI Development

### 2.1. Continuing Expansion and Development of Routine e-VLBI Data Transfers

MPI continues regular e-VLBI transfers of data for which the Bonn correlator is the correlation target. This includes data from Japan, Onsala, Ny-Ålesund, and Wettzell. All data recorded on the K5 system at Tsukuba and Kashima are transferred either to MPI or Haystack depending on the target correlator. Syowa K5 data are physically shipped to Japan and electronically transferred to Haystack or MPI. UT1 Intensive data from Wettzell, Tsukuba and Ny-Ålesund are transferred to either MPI or the Washington correlator, which is now connected to the world at ~600 Mbps! Welcome news! After a long and tortured process, connection of the Kokee station in early 2010 now seems likely. This connection will help lower the processing latency for time-critical UT1 data from days to hours.

### 2.2. 8th International e-VLBI Workshop Held at Madrid, Spain

The 8th International e-VLBI Workshop was held 22-26 June 2009 in Madrid, Spain, hosted by the Centro Nacional de Información Geográfica—Instituto Geográfico Nacional (CNIG-IGN) of Spain in cooperation with the EXPReS project. The workshop was attended by more than 80 participants from 19 countries.

Presentations at the workshop showed continuing progress in e-VLBI on several fronts. In Europe, the JIVE EXPReS project continues to connect European astronomical VLBI telescopes in real-time and conducts regular scientific e-VLBI experiments with up to 5-8 stations at data rates up to 1 Gbps/station, with some data connection speeds being as high as 10 Gbps (but without being correlated in real-time). Australia and Japan continue to make rapid progress in connecting telescopes. Korea is pursuing an aggressive e-VLBI plan as telescope construction continues there.

All presentations from the Madrid workshop are available at the on-line Proceedings of Science at <http://pos.sissa.it/cgi-bin/reader/conf.cgi?confid=82>. The 9th International e-VLBI Workshop will be held in Perth, Australia in 2010. We all look forward to another valuable and stimulating meeting.

## 3. Global VLBI Standards

### 3.1. VLBI Data Interchange Format (VDIF) Task Force

One important outcome of the 7th International e-VLBI Workshop in Shanghai in 2008 was the creation of a task force to study and recommend a universal VLBI data format that is suitable for both on-the-wire e-VLBI data transfer, as well as direct disk storage. This task force, called the VLBI Data Interchange Format (VDIF) Task Force, was envisioned as the first part of a two part effort, the second of which will address standardization of e-VLBI data-transmission-protocols (so-called VTP). The VDIF Task Force, consisting of Mark Kettenis (JIVE), Chris Phillips (ATNF), Mamoru Sekido (NICT), and Alan Whitney (MIT Haystack, chair), presented a proposed VDIF specification at the June 2009 Madrid meeting. The Task Force was gratified that the proposed specification was well-received and, after some discussion, ratified by the attendees. The VDIF specification is discussed in detail in other papers in this report and is available on-line

at <http://vlbi.org>. A VTP Task Force, led by Chris Phillips of ATNF, was appointed to lead the development of the second half of this standardization effort, which is now an on-going effort.

### 3.2. VEX2 Task Force

The VEX file format was invented by Alan Whitney in 1995 as a standardized method to prescribe a complete description of a VLBI experiment, including setup, scheduling, data-taking and correlation, independent of any particular VLBI data-acquisition system or correlator. VEX has gained quite broad acceptance and is used to support a very large fraction of global VLBI observations. However, as VLBI technology and data-taking methods have marched on since 1995, VEX is now in need of a significant globally coordinated update. At a U.S. VLBI technology meeting in November 2009, and in collaboration with international colleagues, a VEX2 Task Force was created to undertake this job. The members of the VEX2 Task Force are Walter Brisken (NRAO, chair), Ed Himwich (NASA/GSFC), Mark Kettenis (JIVE), Cormac Reynolds (Curtin University), and Alan Whitney (MIT Haystack). This group will be working over the next 6-12 months to craft the needed standardized updates and to incorporate them into several VLBI-support software packages.

## 4. VLBI Digital-Backend Intercomparison Testing

On 4-5 May 2009, the first intercomparison zero-baseline correlation testing was done between digital backends (DBEs) that have been independently designed at different organizations. The results of this testing are the first step in a more thorough investigation that also includes actual VLBI observations.



Figure 2. DBE intercomparison test setup at Haystack Observatory

Three systems were brought together at Haystack for testing:

1. A European “dBBC” system configured with polyphase filter bank (PFB) firmware. The dBBC was accompanied by Gino Tuccari of INAF/IRA.
2. A Chinese “CDAS” (Chinese Digital Data Acquisition System), configured with eight tunable dual-sideband digital BBCs. The CDAS was accompanied by Drs. Wenren We, Li Bin, Wu Yajun, and Zhu Renjie of Shanghai Observatory.
3. A Haystack “DBE1” system based on the Berkeley-designed hardware and Haystack firmware, configured with PFB firmware. The DBE1 was accompanied by Haystack staff Arthur Niell, Chris Beaudoin, and Alan Whitney.

The testing was done by injecting correlated broadband noise into the digital backends, both with and without local-oscillator offsets, and then cross-correlating all three combinations of units on the Haystack Mark IV correlator.

#### 4.1. Testing Results

The testing of the units went well, with only the usual sort of small difficulties that occur when such tests are done with complicated equipment. It was fortunate that we had three DBE units to test, as it greatly eased diagnosing the effects of any particular DBE unit; without three units, testing would have been much more difficult.

The testing indicated full compatibility between the dBBC and DBE1 units, with minor problems discovered in the CDAS unit. These minor problems have subsequently been fixed. Further compatibility tests are planned using real VLBI observations. A full report on the DBE compatibility testing is available at [http://www.haystack.edu/geo/vlbi\\_td/BBDev/036.pdf](http://www.haystack.edu/geo/vlbi_td/BBDev/036.pdf).





Network Stations

Network Stations





# Badary Radio Astronomical Observatory

*Sergey Smolentsev, Roman Sergeev*

## Abstract

This report provides information about the Badary network station: general information, facilities, staff, present status, and outlook.

## 1. General Information

The Badary Radio Astronomical Observatory (BdRAO) was founded by the Institute of Applied Astronomy (IAA) as one of three stations of the Russian VLBI network QUASAR. The sponsoring organization of the project is the Russian Academy of Sciences (RAS). The Badary Radio Astronomical Observatory is situated in the Buryatia Republic (East Siberia) about 130 km east of Baikal Lake (see Table 1). The geographic location of the observatory is shown on the IAA RAS Web site (<http://www.ipa.nw.ru/PAGE/rusipa.htm>). The basic instruments of the observatory are a 32-m radio telescope (see Fig. 1) and technical systems for making VLBI observations.



Figure 1. Badary Observatory.

Table 1. Badary Observatory location and address.

Longitude	102°14'
Latitude	51°46'
Badary Observatory Republic Burytia 671021, Russia sergeev@ipa.nw.ru	

## 2. Technical and Scientific Information

The Badary station equipment includes the following main components: a 32-m radio telescope equipped with low noise receivers, a frequency and time keeping system with H-masers CH1-80 and CH1-80M, a local geodetic network, a GPS receiver Leiga SR 520 (geodetic) and a GPS/GLONASS K161 receiver (for synchronization of the time keeping system), a data acquisition system R1001, a Mark 5B recording terminal, and an automatic meteorological station WXT510 (Vaisala). Characteristics of the radio telescope are presented in Table 2.

The Badary Observatory was connected with main line optical fiber glass.

Table 2. Technical parameters of the radio telescope.

Year of construction	2005
Mount	AZEL
Azimuth range	$\pm 270$ (from south)
Elevation range	from $-5^\circ$ to $95^\circ$
Maximum azimuth	
- velocity	$1.5^\circ/\text{s}$
- tracking velocity	$1.5'/\text{s}$
- acceleration	$0.2^\circ/\text{s}^2$
Maximum elevation	
- velocity	$0.8^\circ/\text{s}$
- tracking velocity	$1.0'/\text{s}$
- acceleration	$0.2^\circ/\text{s}^2$
Pointing accuracy	better than $10''$
Configuration	Cassegrain (with asymmetrical sub-reflector)
Main reflector diameter	32 m
Sub-reflector diameter	4 m
Focal length	11.4 m
Main reflector shape	quasi-paraboloid
Sub-reflector shape	quasi-hyperboloid
Surface tolerance of main reflector	$\pm 0.5$ mm
Frequency capability	1.4–22 GHz
Axis offset	2.5 mm $\pm 0.5$ mm

## 3. Technical Staff

Roman Sergeev — Observatory chief,  
 Nicolay Mutovin — FS, pointing system controls,  
 Alexander Seryh — front end and receiver support.

#### 4. Current Status and Activities

Badary observatory participates in IVS and Russian Domestic VLBI observations.

During 2009 the Badary IVS station participated in 61 IVS sessions as shown in Table 3: 13 – IVS-R1, 40 – IVS-R4, 2 – IVS-T2, 4 – EURO, 1 – IVS-R&D, 1 – IYA09.

Table 3. List of IVS sessions observed at Bd RAO in 2009.

Month	IVS-R1	IVS-R4	IVS-T2	EURO	IVS-R&D	IYA09
January		4		1		
February	1	4			1	
March	1	4		1		
April	2	4	1			
May	1	4		1		
June	2	4				
July	2	5				
August		2	1			
September		3		1		
October	2	2				
November	2	1				1
December		3				
Total	13	40	2	4	1	1

During 2009 Badary participated in VLBI observations of the QUASAR network: in 20 Ru-E sessions (24-hour sessions for EOP monitoring) and 28 Ru-U sessions (4 1-hour sessions for UT1 measurement); 17 of these were provided in e-VLBI mode. In April 2009 the first e-VLBI session was successfully carried out. Since September 2009 Ru-U sessions for UT1 have been held in e-VLBI mode.

The Badary observatory has a permanent GPS receiver Leica SR520. The accuracy of the local geodetic network (LGN) is about 2 mm.

A DORIS antenna was installed at Badary in September 2009.

#### 5. Future Plans

Our plans for the coming year are the following:

- Participation in 42 IVS observing sessions: IVS-R1, IVS-R4, IVS-T2, and EURO.
- Participation in weekly domestic observational sessions for obtaining Earth orientation parameters and in weekly 1-hour e-VLBI sessions for UT1 determination.
- Surveying the local geodetic network.
- GPS Javad receiver installation.
- Preparation for laser ranging system installation.
- Participation in EVN observations.

## Fortaleza Station Report for 2009

*Pierre Kaufmann, A. Macílio Pereira de Lucena, Adeildo Sombra da Silva,  
C. Guillermo Gimenez de Castro*

### Abstract

This is a brief report about the activities carried out at the Fortaleza geodetic VLBI station (ROEN: Rádio Observatório Espacial do Nordeste), located in Eusébio, CE, Brazil, in 2009. The observing activities consisted of 52 VLBI sessions and continuous GPS monitoring recordings. The installation of optical fiber was completed, and the station switched to a 1 Gbit/s high speed network, to be used in e-VLBI operations. Regular GPS observations were carried out at the same site. A major mechanical failure of the antenna positioner has interrupted observations in November 2009.

### 1. General Information

The Rádio Observatório Espacial do Nordeste, ROEN, located at INPE facilities in Eusébio, nearly 30 km east of Fortaleza, Ceará State, Brazil, began operations in 1993. Geodetic VLBI and GPS observations are carried out regularly, as contributions to international programs and networks. ROEN is part of the Brazilian space geodesy program, which was initially conducted by CRAAE (a consortium of the Brazilian institutions Mackenzie, INPE, USP, and UNICAMP) in the early 1990s. The program began with antenna and instrumental facilities erected, with activities sponsored by the U.S. agency NOAA and the Brazilian Ministry of Science and Technology's FINEP agency. ROEN is currently coordinated by CRAAM, Center of Radio Astronomy and Astrophysics, Engineering School, Mackenzie Presbyterian University, São Paulo, in agreement with the Brazilian National Space Research Institute, INPE. The activities are currently carried out under an Agreement of Cooperation signed between NASA—representing research interests of NOAA and USNO—and the Brazilian Space Agency, AEB, lasting until 2011. Under the auspices of the NASA-AEB Agreement, a new contract was signed between NASA and CRAAM, Mackenzie Presbyterian Institute and University to extend partial support to the activities until 2014. The remainder of the operational costs, staff, and infrastructure support are provided by INPE and by Mackenzie.

### 2. Component Description

The largest instrument of ROEN is the 14.2 m radio telescope, an alt-azimuth positioner. It is operated at S- and X-bands, using cryogenic radiometers. The system is controlled by the Field System, Version 9.9.2. Observations are recorded with a Mark 5 system. One Sigma-Tau hydrogen maser clock standard is operated at ROEN. GPS monitoring is performed within a cooperative program with NOAA (USA). There is a Leica System 1200 installed at the station that operates continuously. The collected data are provided to the NOAA/IGS center and to the Brazilian IBGE center. ROEN has all basic infrastructures for mechanical, electrical, and electronic maintenance of the facilities.



## 4.2. Development and Maintenance Activities in 2009

Considerable attention was given to technical maintenance, especially to the following activities:

- 1) Maintenance of the cryogenic system,
- 2) Replacement of Mark IV video converters and rack power supplies,
- 3) Maintenance of the Mark 5 recorder and disc pack modules,
- 4) Update of Mark 5 operational system and software for testing the high speed network,
- 5) Repair of receiver temperature controller,
- 6) Tests of the high speed network for e-transfers and e-VLBI,
- 7) Maintenance of the Web site (<http://www.roen.inpe.br>) and the local server computer,
- 8) Repair and alignment of azimuth gear box,
- 9) Adjustment of elevation and azimuth motor electronics, and
- 10) Diagnostic activities performed trying to identify a problem on azimuth bearing.

## 4.3. GPS Operations

The IGS network GPS receiver operated regularly at all times during 2009. Data were collected and uploaded to an IGS/NOAA computer.



Figure 3. Detail of GPS antenna placed over the main building.

## 4.4. High Speed Network

During 2009, we kept testing the performance between Fortaleza/Eusébio (ROEN) station, which is connected to the RNP (Rede Nacional de Pesquisas—Brazil National Research Network) and Haystack Observatory. We also started performance tests with the VLBI Correlator at Bonn (UBonn/BKG) and with Australia (CSIRO/ATNF). The data rates we obtained were at 255 Mbps on average with Australia; problems related to the traffic of UDP packages did not permit us to get a measurement of the network performance between Fortaleza and the German correlator. Some interconnection problems were detected and are being solved to improve that performance.



Figure 4. Structure of the Brazilian National Research Network (RNP) ([http://www.rnp.br/\\_media/graficos/backbone-rnp-200911.jpg](http://www.rnp.br/_media/graficos/backbone-rnp-200911.jpg)).

#### 4.5. Meetings, Visits and Collaborations

In April 2009, a meeting between ROEN staff, the Director and staff members of the National Research Network (RNP), and researchers of the Presbyterian University Mackenzie was held in São Paulo to discuss strategies to diagnose and enhance the high speed connection.

ROEN was present at the 8th International e-VLBI Workshop, June 22-26, 2009, Madrid, Spain, organized by the Instituto Geográfico Nacional in cooperation with the EXPReS project, by one member of the office in São Paulo. A staff member of the RNP was also present. During the meeting, a collaboration with the ATNF was initiated to carry on observations.

Between August 25-28, IVS Chair Dr. Harald Schuh visited ROEN where he presented two talks related to VLBI. The opportunity was used to meet ROEN staff, solve some problems related to the high speed tests, and discuss new collaboration plans.

#### 5. Future Plans

The optimized high speed optical network connection will allow ROEN to participate in e-VLBI experiments. The tests for improvement of the network data rates are currently being carried out. One interesting possibility is the installation of a software correlator at Mackenzie University. At the moment the University does not have permanent access to the RNP backbone. Tests to qualify the present high speed connection Mackenzie/Fortaleza are under way.

#### 6. Acknowledgements

These activities have received partial support from NASA, within an agreement with the Brazilian Space Agency (AEB) and a contract with Mackenzie, as part of an agreement between Mackenzie and INPE.

# Goddard Geophysical and Astronomical Observatory

*Jay Redmond, Irv Diegel, Mark Evangelista*

## Abstract

This report summarizes the technical parameters and the technical staff of the VLBI system at the fundamental station GGAO. It also gives an overview about the VLBI activities during the report year. The outlook lists the outstanding tasks to improve the performance of GGAO.

## 1. GGAO at Goddard

The Goddard Geophysical and Astronomical Observatory (GGAO) consists of a radio telescope for VLBI, an SLR site to include MOBLAS-7, NGSRL (development system), a 48" telescope for developmental two color Satellite Ranging, a GPS timing and development lab, meteorological sensors, and an H-maser. In addition, we are a fiducial IGS site with several IGS/IGSX receivers.

GGAO is located on the east coast of the United States in Maryland. It is about 15 miles NNE of Washington, D.C. in Greenbelt, Maryland (Table 1).

Table 1. Location and addresses of GGAO at Goddard.

Longitude	76.4935° W
Latitude	39.0118° N
MV3 Code 299.0 Goddard Space Flight Center (GSFC) Greenbelt, Maryland 20771	
<a href="http://cddisa.gsfc.nasa.gov/ggao/vlbi.html">http://cddisa.gsfc.nasa.gov/ggao/vlbi.html</a>	

## 2. Technical Parameters of the VLBI Antenna at GGAO

The radio telescope for VLBI at GGAO (MV3) was originally built as a mobile or transportable station. It was previously known as Orion and was part of the original CDP. It is now being used as a fixed site, having been moved to Goddard and semi-permanently installed here since the spring of 1991. In the winter of 2002 the antenna was taken off its trailer and permanently installed at GGAO. The design criteria were:

- Transportability on two tractor trailers utilizing a 5 meter dish size to maximize reception and mobility considerations,
- Setup of the radio telescope within eight hours (although it has been used as a fixed site since the spring of 1991)

The technical parameters of the radio telescope are summarized in Table 2.



Table 2. Technical parameters of the radio telescope of GGAO for geodetic VLBI.

Parameter	GGAO-VLBI
Owner and operating agency	NASA
Year of construction	1982
Diameter of main reflector $d$	5m
Azimuth range	0...540°
Azimuth velocity	3°/s
Azimuth acceleration	1°/s <sup>2</sup>
Elevation range	0...90°
Elevation velocity	3°/s
Elevation acceleration	1°/s <sup>2</sup>
X-band	8.18 – 8.98 GHz
Receiving feed	Cassegrain focus
$T_{sys}$	24 K
Bandwidth	800 MHz, -2dB
$G/T$	32.1 dB/K
S-band	2.21 – 2.45 GHz
Receiving feed	Primary focus
$T_{sys}$	19 K
Bandwidth	240 MHz, -2dB
$G/T$	21.2 dB/K
VLBI terminal type	Mark IV
Recording media	Mark 5B
Field System version	9.10.2

### 3. Technical Staff of the VLBI Facility at GGAO

The GGAO VLBI facility gains from the experiences of the Research and Development VLBI support staff. GGAO is a NASA R&D and data collection facility, operated under contract by Honeywell Technology Solutions Incorporated (HTSI). Table 3 lists the GGAO station staff that are involved in VLBI operations.

Table 3. Staff working at the MV3 VLBI station at GGAO.

Name	Background	Dedication	Agency
Jay Redmond	Engineering technician	100%	HTSI
Skip Gordon	Engineering technician	20%	HTSI

#### 4. Status of MV3 at GGAO

Having ceased VLBI operations in May 2007, MV3 continues on a full time basis to be a major component in the program to demonstrate the feasibility of the VLBI2010 broadband delay concept. Working under the guidance of the Haystack Observatory, MV3 has played a critical role in the advancement of the VLBI2010 project.

The Haystack-constructed front end dewar, containing the broadband Lindgren feed, two low noise amplifiers, and a cryogenic refrigerator, has been upgraded to include directional couplers for phase cal injection and high-pass ( $> 3.1$  GHz) filters to reduce the effect of out-of-band RFI. The RF signal path from the antenna to the electronics van consists of two broadband fiber optic links that interface with an Optical Receiver/Splitter/Amplifier (ORCA) for distribution.

The MV3 electronics van is now equipped with a full complement of Haystack-developed VLBI2010 prototype backend equipment, including four Up/Down Converters (UDC), two Digital Back Ends (DBE), and four Mark 5B+ data recorders. This equipment can be controlled remotely via the internet. Additional MV3 modifications include expanded 5 MHz, 1 pulse per second, and Ethernet distribution. The Mark IV recorder was removed in order to accommodate the VLBI2010 equipment.

As a result of both single station tests at MV3 and dual station tests with an identical system at Westford, significant progress has been made in understanding the advantages and limitations of the broadband concept. Several notable results during 2009 include:

- Detection of first fringes from 3.4 to 7 GHz.
- Subsequent detection of fringes from 3.4 to 11.5 GHz, thereby demonstrating the wideband capability of the system.
- Demonstration of the usefulness of satellite signals for focus and pointing settings.
- Implementation of software control of UDCs for easy frequency selection.
- Arrival of the new 12-meter antenna at GGAO (currently in shipping containers at the site).
- Installation of a 1-meter reference antenna and LNAs for use in holography.
- Discovery of excessive RF leakage from the phase cal unit, prompting the development of a new enclosure by Honeywell-TSI.

#### 5. Outlook

GGAO will continue to support VLBI2010, e-VLBI, and other developmental activities during the upcoming year. Tentative plans for 2010 include:

- Characterization of the Eleven feed in conjunction with Haystack Observatory.
- Installation and testing of the new phase calibrator for the VLBI2010 system.
- Installation of the new rDBE and Mark 5C, enabling data recording at 4 Gbps.
- Performance of holography on the 5-meter antenna using a 1-meter reference antenna and geosynchronous satellites.
- Continued investigation and characterization of the performance of the 5-meter MV3 antenna.

- Installation of the new 12-meter VLBI2010 antenna.
- Installation of a second VLBI2010 rack and field system for the new 12-meter antenna.
- Continued broadband observations and testing of the VLBI2010 system.



Figure 1. Close up view of the VLBI2010 wideband prototype dewar at GGAO.

# Hartebeesthoek Radio Astronomy Observatory (HartRAO)

*Ludwig Combrinck, Michael Gaylard, Jonathan Quick, Marisa Nickola*

## Abstract

HartRAO is the only fiducial geodetic site in Africa, and it participates in VLBI, GNSS, SLR, and DORIS global networks, among others. This report provides an overview of steps taken during 2009 towards the repair of the 26-m radio telescope and the conversion of the 15-m Karoo Array Telescope (KAT) prototype to a radio telescope capable of performing geodetic VLBI tasks.

## 1. Geodetic VLBI at HartRAO

Hartebeesthoek is located 65 kilometers northwest of Johannesburg, just inside the provincial boundary of Gauteng, South Africa. The nearest town, Krugersdorp, is 32 km distant. The telescope is situated in an isolated valley which affords protection from terrestrial radio frequency interference. HartRAO uses a 26-meter equatorially mounted Cassegrain radio telescope built by Blaw Knox in 1961. The telescope was part of the NASA deep space tracking network until 1974 when the facility was converted to an astronomical observatory. The telescope is co-located with an ILRS SLR station (MOBLAS-6), an IGS GNSS station (HRAO), and an IDS DORIS station (HBMB) at the adjoining Satellite Application Centre (SAC) site.



Figure 1. HartRAO fiducial site: space geodetic techniques of VLBI, GNSS, and SLR. (Credit: M. Gaylard)

## 2. Technical Parameters of the 26-m Telescope of HartRAO

Table 1 contains the technical parameters of the HartRAO radio telescope and the Karoo Array Telescope (KAT) prototype, XDM (eXperimental Development Model), while Table 2 contains technical parameters of the HartRAO 26-m radio telescope's receivers. The data acquisition system consists of a Mark IV terminal and a Mark 5A recorder.

Table 1. Antenna parameters.

Parameter	HartRAO-26 m	KAT 15-m XDM
Owner and operating agency	HartRAO	HartRAO
Year of construction	1961	2007
Radio telescope mount	Offset equatorial	Az-El
Receiving feed	Cassegrain	Prime focus
Diameter of main reflector $d$	25.914 m	15 m
Focal length $f$	10.886 m	7.5 m
Focal ratio $f/d$	0.424	0.5
Surface error of reflector	0.5 mm	$\sim 2.5$ mm
Short wavelength limit	1.3 cm	2 cm
Pointing resolution	0.001°	0.001°
Pointing repeatability	0.004°	not tested
Slew rate on each axis	HA: $0.5^\circ s^{-1}$ Dec: $0.5^\circ s^{-1}$	Az: $2^\circ s^{-1}$ El: $1^\circ s^{-1}$

Table 2. 26-m receiver parameters with dichroic reflector (DR), used for simultaneous S-X VLBI, off or on.

Parameter	X-band	S-band
Feeds	dual CP conical	dual CP conical
Amplifier type	cryo HEMT	cryo HEMT
$T_{sys}$ (DR off) ( $K$ )	60	44
$T_{sys}$ (DR on) ( $K$ )	70	50
$S_{SEFD}$ (DR off) ( $Jy$ )	684	422
$S_{SEFD}$ (DR on) ( $Jy$ )	1330	1350
Point source sensitivity (DR off) ( $Jy/K$ )	11.4	9.6
Point source sensitivity (DR on) ( $Jy/K$ )	19	27
3 dB beamwidth (°)	0.092	0.332

## 3. Current Status and Future Plans

Due to the failure of the 26-m radio telescope's south polar bearing on the 3rd of October 2008, shortly after the CONT08 campaign, HartRAO has not been able to participate in any geodetic VLBI experiments during 2009. With its limited drivability, the 26-m could only be operated as a transit instrument. All systems have been kept alive. The breakdown has afforded the opportunity

to embark upon thorough and long overdue maintenance tasks. The 26-m's 3.5- and 13-cm HEMT LNAs have been replaced and the old ones passed on to the 15-m XDM.

Midway through 2009 it was decided that the 26-m telescope's failed bearing would be replaced and that it would be returned to service. In October 2009 the NRF obtained the required funds for the international engineering firm, General Dynamics, to repair the 26-m telescope. The first phase consists of the construction of supports to allow the telescope structure above the main polar drive shaft to be lifted so that the south polar bearing may be replaced. The groundbreaking for the erection of the support structure was on March 23, 2010. The 26-m's return to service is currently expected in August 2010.

In order to reduce the number of frequent slews on the 26-m, the 15-m XDM (KAT prototype) will be converted for use in geodetic VLBI experiments. During 2009 and early 2010, a prototype S-X feed/receiver was designed for the XDM and underwent extensive testing. Production of a cryogenic system has begun. The XDM's time to enter geodetic VLBI service is currently not known.

We hope to acquire additional VLBI terminal components (e.g., sampler) so that the 26-m and the 15-m will be able to participate in VLBI simultaneously, with the regular geodetic VLBI sessions being off-loaded to the 15-m. Jonathan Quick has made good progress in adapting the 26-m's NCCS (New Control Computer System) so that it can be used to control the 15-m XDM. Ludwig Combrinck is supposed to survey in the 15-m XDM with the other co-located geodetic instruments. The continued use of the 26-m radio telescope with the addition of the 15-m XDM for geodetic VLBI sessions, should allow sufficient time for the envisaged new fundamental geodetic station with its VLBI2010 radio telescope to establish itself as a fiducial site.

Planning for the construction of a GGOS antenna at the Matjiesfontein outstation site continued at both Space Geodesy Observatory workshops held in Matjiesfontein during 2009. The workshop in March was attended by interested parties from the German Space Operations Center (DLR/GSOC), Hermanus Magnetic Observatory (HMO) as well as the Council for Geosciences (CGS). Plans are also under discussion for the construction of a GGOS antenna in Mozambique in collaboration with South Africa's Department of Science and Technology (DST).

The Space Geodesy Programme is an integrated program, combining VLBI, SLR, and GNSS, and it is active in several collaborative projects with GSFC, JPL, and GFZ (Potsdam) as well as numerous local institutes. Collaboration also includes CNES/GRGS/OCA and the ILRS community in a Lunar Laser Ranger (LLR) project with local support from the University of Pretoria and the National Laser Centre (CSIR), among others. General information as well as news and progress on Geodesy and related activities can be found at <http://geodesy.hartrao.ac.za/>.



Figure 2. 15-m XDM: the KAT prototype is to be converted to a radio telescope capable of performing geodetic VLBI experiments. (Credit: M. Gaylard)



Figure 3. XDM feeds and receiver: prototype S-X feeds and components for the receiver. (Credit: R. Myataza)



Figure 4. Groundbreaking: cutting the slab for the construction of the 26-m's A-frame support; in the background, the XDM is being put through its paces using the adapted 26-m observing scheduler. (Credit: M. Gaylard)

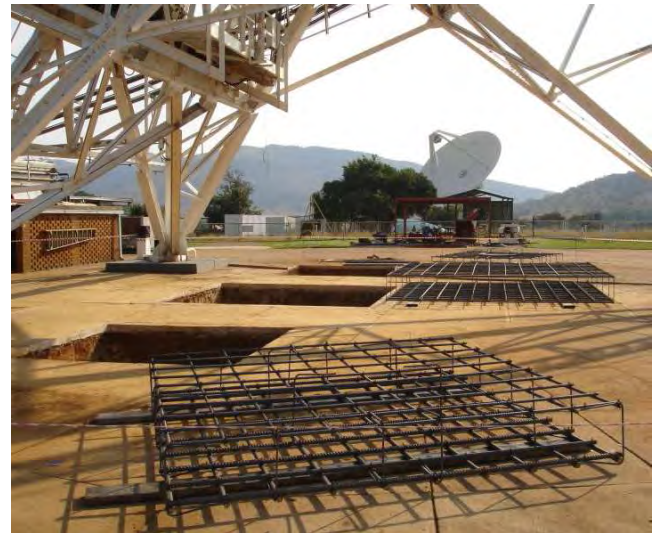

Figure 5. Rebars ready: steel reinforcing bars for the A-frame support's three concrete foundation slabs are ready to go into the ground. (Credit: M. Gaylard)

# Hobart, Mt. Pleasant Station and AuScope VLBI Project Report

*Jim Lovell, John M. Dickey, Brett Reid, Simon Ellingsen*

## Abstract

This is a brief report on the activities carried out at the Mt. Pleasant Radio Astronomy Observatory at Hobart, Tasmania. During 2009, the Observatory participated in 58 IVS VLBI observing sessions of 24 hours each. Construction of the Hobart 12 m antenna for the AuScope VLBI array was completed, and the year ended with a successful fringe-check between it and the 26 m antenna. Construction of the Katherine antenna was also completed, and work began on the third antenna at Yarragadee.

## 1. Introduction

The Mt. Pleasant Observatory is located about 15 km north east of Hobart at longitude 147.5 degrees East and latitude 43 degrees South. Hobart is the capital city of Tasmania, the island state of Australia located to the south of the mainland. The station is operated by the School of Mathematics and Physics at the University of Tasmania. The station has a co-located GPS receiver and a site which is used for absolute gravity measurements.

## 2. Brief Description of Hobart 26 m VLBI Facilities

The antenna is a 26 m prime focus instrument with an X-Y mount. The focus cabin has a feed translator with provision for four different receiver packages, which enables rapid changeover between geodetic and astronomical requirements. Standard receiver packages provide for operation at L band, S, C, X and K bands. There is also a dual frequency cryogenic S/X geodetic receiver. All of these receivers are cryogenically cooled. The antenna has a maximum slew rate of 40 degrees per minute about each axis. The station is equipped with a Mark IV electronics rack and a Mark 5 VLBI recording system. There is another disk based recording system used by other Australian VLBI antennas.

## 3. Staff

Staff at the observatory consist of academics, Prof. John Dickey (director), Dr. Simon Ellingsen and Prof. Peter McCulloch, who has a large input into the receiver design and implementation. Dr. Jim Lovell is Project Manager for the AuScope VLBI project. Dr. Jamie McCallum is a post-doctoral fellow and has had input into the development and implementation of AuScope-related hardware at the observatory. Mr. Tim Hoban is employed as a computer programmer for the AuScope project. Mr. Brett Reid is the Observatory Manager whose position is funded by the university. In addition we have two electronics technical officers, Mr. Eric Baynes and Mr. Brenton Jones. For operation of the observatory during geodetic observations we rely heavily on support from astronomy PhD. and post-graduate students.



#### 4. Geodetic VLBI Observations

The Hobart 26 m antenna participated in 58 geodetic VLBI experiments during 2009. These were divided between the APSG (2), CRF (4), IYA09 (1), OHIG (5), R1 (32), R4 (11), R&D-2 (1), RDV (1) and T2 (1) programs. The 26 m also participated in five astrometry/geodesy-related observations with other IVS stations and the Australian Long Baseline Array: TANAMILBA (4) and LBA-V271CR (1). All experiments were recorded using Mark 5A.

#### 5. The AuScope VLBI Project

AuScope is part of the Australian Government's National Collaborative Research Infrastructure Strategy (NCRIS). It encompasses NCRIS Capability 5.13: "Structure and Evolution of the Australian Continent". An important part of this is the acquisition of three new radio telescopes and a data processing facility for geodesy. AuScope aims to provide a fundamental reference frame in Australia to 1 mm accuracy based on the locations of three radio telescopes as established by VLBI observations. Each site will also host a permanent GPS receiver to tie the telescope reference frame to a denser GPS frame of  $\sim 100$  antennas across the continent. The construction and operation of the array is being managed by the University of Tasmania with data correlation supported by Curtin University of Technology.

Three 12 m diameter antennas are being supplied by Patriot Products division of Cobham Satcom. The antennas have surface accuracies of 0.3 mm RMS and slew rates of 5 deg/s in azimuth and 1.25 deg/s in elevation. During 2009, the first antenna was built and commissioned at Mt. Pleasant, the second was built at Katherine (Northern Territory), and work on the third at Yarragadee (Western Australia) commenced. Once commissioned, the AuScope VLBI array will replace the Hobart 26 m antenna as the University of Tasmania's contribution to IVS. The AuScope VLBI array will eventually participate in geodetic observations for 180 days per year. Each site will be equipped with room temperature S/X receiver systems, Vremya-ch Hydrogen maser standards, HAT-Lab DBBC samplers and Conduant Mark 5B+ recorders. 2009 ended with the first successful fringe detection between the Hobart 12 m and 26 m antennas on December 23.

This five year project, for which funding started in 2007, will vastly improve the capabilities of the IVS in the southern hemisphere. The construction and operation of the array is being managed for AuScope by the University of Tasmania.



Figure 1. The three AuScope VLBI sites as of 24 December 2009 (photos by Jim Lovell, Brett Reid and Vince Noyes).

# Kashima 34-m Radio Telescope

*Eiji Kawai, Mamoru Sekido, Ryuichi Ichikawa*

## Abstract

The Kashima 34-m radio telescope is continuously operated and maintained by the National Institute of Information and Communications Technology (NICT) as a facility of the Kashima Space Research Center (KSRC) in Japan. This brief report summarizes the status of this telescope, the staff and activities during 2009.

## 1. General Information

The Kashima 34-m radio telescope (Figure 1, left) was constructed as a main station of the “Western Pacific VLBI Network Project” in 1988. After that project’s termination, the telescope has been used not only for geodetic purposes but also for astronomy and other purposes [1]. The station is located about 100 km east of Tokyo, Japan and co-located with the 11-m radio telescope and the International GNSS Service station (KSMV) (Figure 1, right). This station is maintained by the Space-Time Measurement Project of the Space-Time Standards Group of KSRC, NICT.

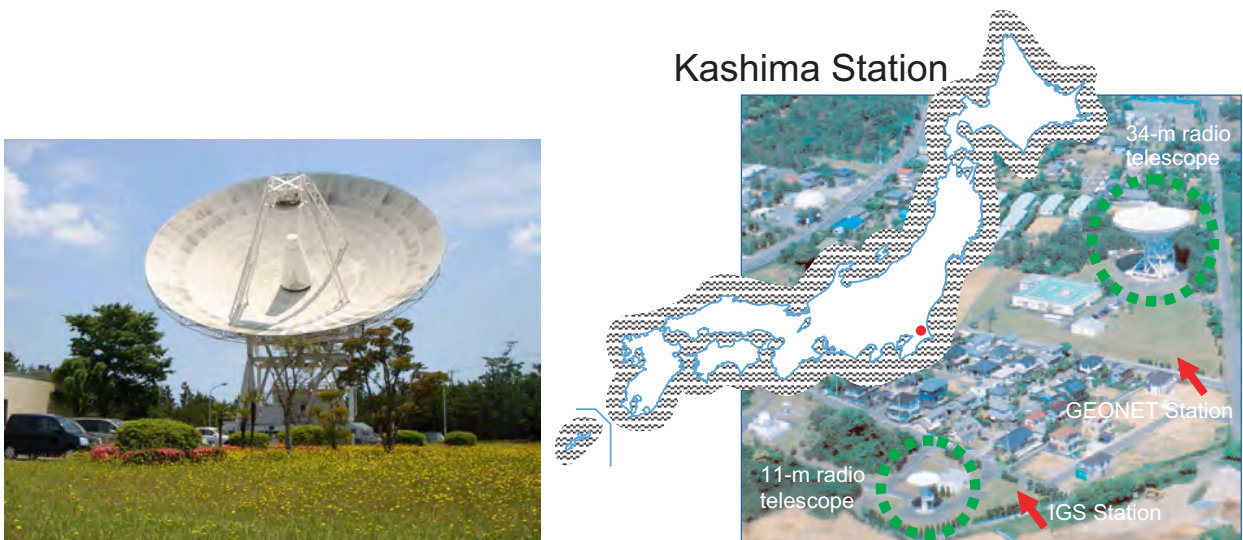

The Kashima 34-m radio telescope.

The layout map of Kashima station.

Figure 1. The Kashima Station.

## 2. Component Description

The Kashima 34-m radio telescope can observe L, C, K, Ka, Q, S, and X bands. The main specifications of the telescope and receivers are summarized in Table 1 and Table 2.

The original frequency coverage of the X-band was from 7860 MHz to 8600 MHz. In order to support IVS observing, we expanded the frequency range of the X-band receiver up to 9080 MHz [2]. For S-band, we have been using the high-temperature superconductor (HTS) band-pass filter

to mitigate the radio frequency interference (RFI) signal due to a third-generation mobile phone system (IMT-2000) [3]. For L-band, we also installed a band-pass filter to mitigate RFI on July 15, 2008. The band-pass frequency is from 1405 to 1435 MHz.

Table 1. Main specifications of the 34-m radio telescope.

Main reflector aperture	34.073 m
Latitude	N 35° 57' 21.78"
Longitude	E 140° 39' 36.32"
Height of AZ/EL intersection above sea level	43.4 m
Height of azimuth rail above sea level	26.6 m
Antenna design	Modified Cassegrain
Mount type	AZ-EL mount
Drive range azimuth	North $\pm 270^\circ$
Drive range elevation	7°-90°
Maximum speed azimuth	0.8°/sec
Maximum speed elevation	0.64°/sec
Maximum operation wind speed	13 m/s
Panel surface accuracy r.m.s.	0.17 mm

Table 2. The receiver specification of the 34-m radio telescope.

Band	frequency (MHz)	Trx (K)	Tsys (K)	Efficiency	SEFD (Jy)	Polarization
L	1350-1750*	18	45	0.68	200	L/R
S	2193-2350	19	72	0.65	340	L/R
C	4600-5100	100	127	0.70	550	L(R)
X-n	8180-9080*	41	48	0.68	210	L/R
X-wL	8180-9080#	41	67	0.68	300	L/R
X-wH	7860-8360#	-	67	0.68	300	L/R
K	22000-24000	105	141	0.5	850	L(R)
Ka	31700-33700	85	150	0.4	1100	R(L)
Q	42300-44900	180	350	0.3	3500	L(R)

\* : 8GHz LNA narrow band use. # : 8GHz LNA wide band use.

\* : Narrow bandwidth filter, 1405 - 1435 MHz, is used generally to mitigate RFI.

### 3. Staff

The engineering and technical staff of the Kashima 34-m radio telescope are listed in Table 3. Shingo Hasegawa joined K5 operation and data transfer. Tetsuro Kondo has been working in Korea since April 2008, but he continues to support the software correlator of NICT. Yasuhiro Koyama moved to NICT HQ in July 2008, but he also continues to support the 34-m antenna. Ryuichi Ichikawa is responsible for the project at Kashima.

Table 3. The engineering and technical staff of the Kashima 34-m radio telescope.

Name	Main Responsibilities
Eiji Kawai	responsible for operations and maintenance
Mamoru Sekido	software and reference signals
Kazuhiro Takefuji	mechanical and RF related parts
Shingo Hasegawa	K5 operation and data transfer
Ryuichi Ichikawa	responsible for the project
Yasuhiro Koyama	international e-VLBI
Tetsuro Kondo	software correlator development and e-VLBI

#### 4. Current Status and Activities

The 34-m radio telescope contributed to various experiments (such as geodesy, radioastronomy, space navigation, and time transfer). Statistical charts of the telescope operation time according to purpose, including maintenance, is shown in Figure 2. The total operation time during 2009 was 1246.5 hours, which decreased compared to the previous year's total of 2047 hours. The main reason for this is that there was repainting of the backup structure and quadripod.

The repainting of the backup structure was carried out from February until March, and from September until October. The repainting period was about three months.

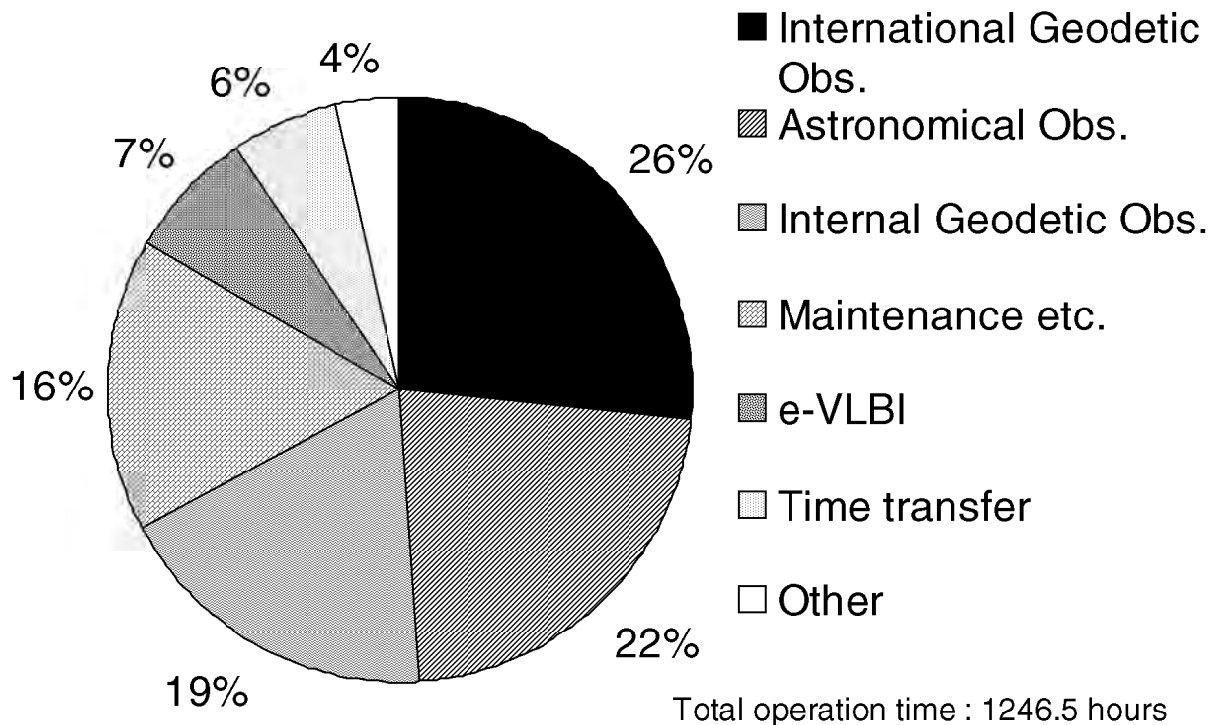

Figure 2. Statistical charts of the telescope operation time according to purpose.

## 5. Future Plans

The Kashima 34-m radio telescope is a main telescope of our project, and already a lot of sessions such as “Experiment for the development of a 1.6 m antenna system”, “Ultra-rapid UT1 experiment with e-VLBI”, and “VLBI experiment for Time Transfer” have been scheduled. We are planning annual maintenance in February and March. Also we are planning repainting in June and July to keep up the telescope’s good condition.

## References

- [1] Kawai, E., M. Sekido, R. Ichikawa, Kashima 34-m Radio Telescope, International VLBI Service for Geodesy and Astrometry 2008 Annual Report, NASA/TP-2009-214183, D. Behrend and K. D. Baver (eds.), pp. 114–117, 2008.
- [2] Kawai, E., H. Kuboki, Y. Koyama, T. Kondo, On the expansion of the frequency coverage of an X-band of Kashima 34-m antenna, IVS NICT TDC News, 26, pp. 23–25, 2005.
- [3] Kawai, E., J. Nakajima, H. Takeuchi, H. Kuboki, T. Kondo, M. Suzuki, K. Saito, RFI mitigation at a 2 GHz band by using a wide-band high-temperature superconductor filter, J. Geod. Soc. Jpn., Vol. 54, No. 1, pp. 31–37, 2008.

# Kashima and Koganei 11-m VLBI Stations

*Hiroshi Takiguchi, Mamoru Sekido, Eiji Kawai, Yasuhiro Koyama*

## Abstract

Two 11-m VLBI antennas at Kashima and Koganei are continuously operated and maintained by the National Institute of Information and Communications Technology (NICT). This brief report summarizes the status of these antennas, the staff, and the activities during 2009.

## 1. Introduction



Figure 1. 11-m VLBI antennas at Kashima (left) and Koganei (right).

Two 11-m VLBI antennas at Kashima and Koganei (Figure 1) used to be stations of the Key Stone Project (KSP) VLBI Network. The network consisted of four VLBI stations at Kashima, Koganei, Miura, and Tateyama (Figure 2). These 11-m antennas and other VLBI facilities at the Miura and Tateyama stations have been transported to the Tomakomai Experimental Forest of the Hokkaido University and to the campus of Gifu University, respectively. As a consequence, two 11-m stations at Kashima and Koganei remain as IVS Network Stations. The KSP was a research and development project of the National Institute of Information and Communications Technology (NICT, formerly Communications Research Laboratory) [1]. After the regular VLBI sessions with the KSP VLBI Network terminated in 2001, the 11-m VLBI stations at Kashima and Koganei have mainly been used for the purposes of technical developments and miscellaneous observations.

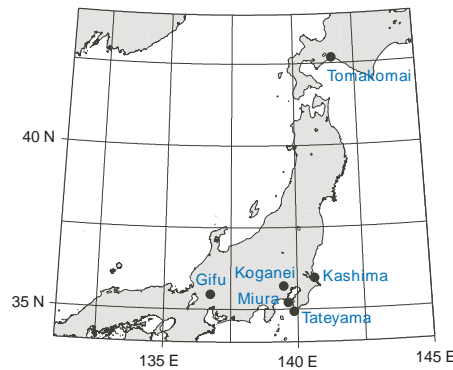

Figure 2. Geographic locations of four KSP VLBI stations and two stations at Tomakomai and Gifu.

## 2. Current Status

The main specifications of these antennas are summarized in Table 1. These antennas can observe S and X-band. Originally, the specifications of these antennas were the same. However, the specifications were changed due to the improvement and the breakdown of the equipment. Also, we changed the phase calibration (P-cal) unit from a 5 MHz to a 1 MHz signal.

Table 1. The specifications of the KSP 11-m antenna

		Kashima	Koganei
Antenna Type		Cassegrain type	
Diameter of the Main Reflector		11-m	
Mount Style		Az El mount	
Latitude		N 35° 57' 20.13"	N 35° 42' 38.01"
Longitude		E 140° 39' 26.90"	E 139° 29' 17.10"
Height of Az/El intersection above sea level		62.4 m	125.4 m
Input Frequency (MHz)	S band	2220 ~ 2370	2100 ~ 2500
	X Low-band	7700 ~ 8200	7700 ~ 8200
	X High band	8180 ~ 8680	8100 ~ 8600
Local Frequency (MHz)	S band	3000	3000
	X Low band	7200	7200
	X High band	7680	7600

In November 2009, we observed the Tsys of the Kashima and Koganei antennas over the entire sky to research the influence of the radio frequency interference (RFI) signals. In X-band, we did not see an RFI signal. However, in S-band, we detected interference from the RFI signal at each station. According to the Japanese radio frequency allocation table, the source of the RFI signal in S-band is thought to be the wireless LAN in Japan. At Kashima, we introduced a narrower band-pass filter (2210 ~ 2380 MHz) to reject the RFI signal. Figure 3 shows the intermediate frequency (IF) spectrum of S-band (left: before replacement of BPF, right: after replacement). It



clearly shows the replacement of the BPF was effective. We are planning to replace the S-band BPF also in Koganei in the near future.

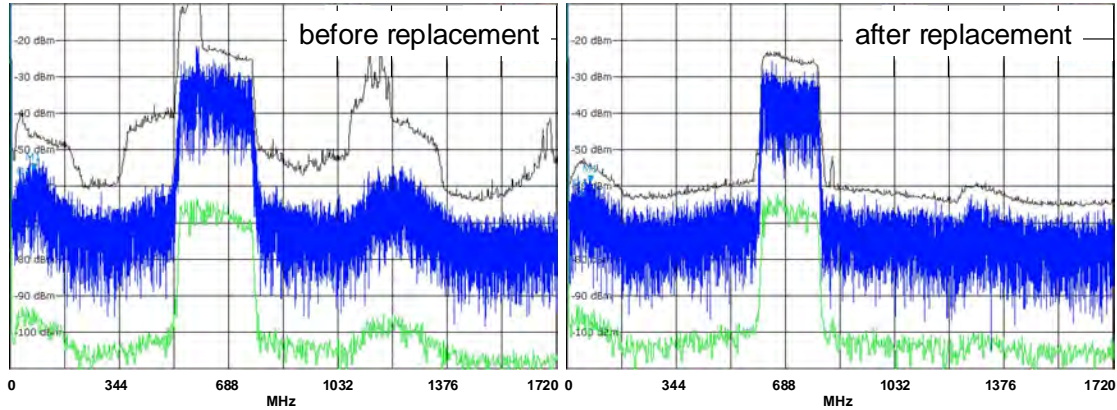

Figure 3. The spectrum of the IF in S-band (left: before replacement of BPF, right: after replacement).

### 3. Activities in 2009

Since 2007, we have been performing special purpose geodetic VLBI experiments between the Kashima (11-m or 34-m) and Koganei (11-m) stations to evaluate the capability of geodetic VLBI for precise time and frequency transfer and comparison. In 2009, the experiments for this purpose were performed in June, August, October, and December. Each time, S/X-band geodetic VLBI observations were performed continuously from 1 to 3 days [2].

For technical developments, the baselines between the Kashima and Koganei stations have also been used in experiments for many purposes—for example, e-VLBI observations, geodetic observations using the MARBLE (Multiple Antenna Radio-interferometry of Baseline Length Evaluation) system, etc. For the results of these experiments, please see the reports from NICT in the “Analysis Centers” and “Technology Development Centers” sections in this volume.

Apart from the VLBI sessions, the Space Environment Group of NICT started to use the 11-m antenna at Koganei to download data from the STEREO spacecraft. Two STEREO spacecraft were launched by NASA in October 2006 to investigate the solar terrestrial environment and to provide 3D images of the Sun and solar storms. The Koganei 11-m antenna is therefore operated every day even if there are no VLBI sessions to perform.

### 4. Staff Members

The 11-m antenna stations at Kashima and Koganei are operated and maintained by the Space-Time Standards Group at Kashima Space Research Center, NICT. The staff members of the group are listed in Table 2. The operation and maintenance of the 11-m VLBI station at Koganei is also greatly supported by the Space-Time Standards Group, the Space Environment Group, and the Space Communications Group at the Koganei Headquarters of NICT. We are especially thankful to Jun Amagai and Tadahiro Gotoh for their support.

Table 2. Staff members of Space-Time Standards Group, KSRC, NICT

Name	Main Responsibilities
KOYAMA Yasuhiro	Administration
KAWAI Eiji	Antenna Systems
ICHIKAWA Ryuichi	Meteorological Sensors, IGS Receivers
AMAGAI Jun	Antenna System and Timing Systems at Koganei 11-m station
SEKIDO Mamoru	Field System, Calibration and Frequency Standard Systems
HASEGAWA Shingo	System Engineer

## 5. Future Plans

In 2010, we plan to continue precise time transfer VLBI experiments and e-VLBI developments. In addition to the VLBI observations and developments, the data downlink from two STEREO spacecraft will be continued. Additionally, we especially are planning to set up the following things to improve the antenna's condition for the precise time and frequency transfer VLBI experiments:

- at the Koganei 11-m station
  - link to the Hydrogen maser coherent with UTC (NICT) by optical fiber
  - repair the temperature control room of KSP Hydrogen maser
  - change the band-pass filter of S-band
- at the Kashima 11-m station
  - set up the precise temperature control room at observation room
  - set up the transportable two-way satellite time and frequency transfer (TWSTFT) system

## References

- [1] Special issue for the Key Stone Project, J. Commun. Res. Lab., Vol. 46, No. 1, March 1999
- [2] Takiguchi, H., Y. Koyama, R. Ichikawa, T. Gotoh, A. Ishii, and T. Hobiger, Comparison Study of VLBI and GPS Carrier Phase Frequency Transfer -Part II-, IVS NICT-TDC News, No. 30, 26-29, 2009.

# Kokee Park Geophysical Observatory

*Ron Curtis*

## Abstract

This report summarizes the technical parameters and the staff of the VLBI system at Kokee Park on the island of Kauai.

## 1. KPGO

Kokee Park Geophysical Observatory (KPGO) is located in the Kokee State Park on the island of Kauai in Hawaii at an elevation of 1,100 meters near the Waimea Canyon, often referred to as the Grand Canyon of the Pacific.



Figure 1. KPGO 20 m and operations building.

Table 1. Location and addresses of Kokee Park Geophysical Observatory.

Longitude	159.665° W
Latitude	22.126° N
Kokee Park Geophysical Observatory P.O. Box 538 Waimea, Hawaii 96796 USA	

## 2. Technical Parameters of the VLBI System at KPGO

The receiver is of NRAO (Green Bank) design (dual polarization feed using cooled 15 K HEMT amplifiers). The DAR rack and tape drive were supplied through Green Bank. The antenna is of the same design and manufacture as those used at Green Bank and Ny-Ålesund. We presently employ a Mark 5A recorder for all of our data recording.

The technical parameters of the radio telescope are summarized in Table 2.

Timing and frequency is provided by a Sigma Tau Maser with a NASA NR Maser providing backup. Monitoring of the station frequency standard performance is provided by a CNS (GPS) Receiver/Computer system. The Sigma Tau performance is also monitored via the IGS Network.

Table 2. Technical parameters of the radio telescope at KPGO.

Parameter	Kokee Park
owner and operating agency	USNO-NASA
year of construction	1993
radio telescope system	Az-El
receiving feed	primary focus
diameter of main reflector $d$	20m
focal length $f$	8.58m
$f/d$	0.43
surface contour of reflector	0.020inchesrms
azimuth range	0...540°
azimuth velocity	2°/s
azimuth acceleration	1°/s <sup>2</sup>
elevation range	0...90°
elevation velocity	2°/s
elevation acceleration	1°/s <sup>2</sup>
X-band (reference $\nu = 8.4GHz, \lambda = 0.0357m$ )	8.1 – 8.9GHz
$T_{sys}$	40 K
$S_{SEFD}(CASA)$	900 Jy
$G/T$	45.05 dB/K
$\eta$	0.406
S-band (reference $\nu = 2.3GHz, \lambda = 0.1304m$ )	2.2 – 2.4GHz
$T_{sys}$	40 K
$S_{SEFD}(CASA)$	665 Jy
$G/T$	35.15 dB/K
$\eta$	0.539
VLBI terminal type	VLBA/VLBA4-Mark 5
Field System version	9.7.6

### 3. Staff of the VLBI System at KPGO

The staff at Kokee Park during calendar year 2009 consisted of five people who are employed by Honeywell Technology Solutions, Inc. under contract to NASA for the operation and maintenance of the observatory. Matt Harms, Chris Coughlin, and Ron Curtis conducted VLBI operations and maintenance. Ben Domingo is responsible for antenna maintenance, with Amorita Apilado providing administrative, logistical, and numerous other support functions. Kelly Kim of Caelum Research Corporation also supports VLBI operations and maintenance during 24-hour experiments and as backup support.



Figure 2. KPGO Maintenance Day.

### 4. Status of KPGO

Kokee Park has participated in many VLBI experiments since 1984. We started observing with GAPE, continued with NEOS and CORE, and are now in IVS R4 and R1. We also participate in the RDV experiments. We averaged 1.5 experiments per week during calendar year 2000 and increased to an average of 2 experiments of 24 hours each week, with daily Intensive experiments, starting in year 2002 and continuing into 2009.

Kokee Park also hosts other systems, including a 7-m PEACESAT command and receive antenna, a DORIS beacon, and a Turbo-Rogue GPS receiver. Kokee Park is an IGS station.

In October of 2007, Japanese interests, along with representatives from NASA, USNO, and the State Department, held a meeting at KPGO to explore the possible installation of a project called Quasi-Zenith Satellite System (QZSS). In 2008, further investigation continued towards making the QZSS project a part of KPGO. NASA sent an engineering team to investigate the support

requirements that would be needed to implement the QZSS project here, and an engineering team from Japan surveyed the site for the hardware that would be installed in 2009. Our aging infrastructure will be upgraded in stages as the project moves along. In September and October of 2009, the power at KPGO was upgraded to support the QZSS and TWSTFT requirements. The installation of these systems is scheduled for March 2010.

Also, in 2008, advances were made for making real-time VLBI data from KPGO a reality. The agencies that will be responsible for the wideband pipes leading from the site entered into a service agreement late in 2008. The coordination with the parties involved in the communication infrastructure upgrades continued through 2009. Initially, the daily Intensive experiments will be targeted so correlation back at the Washington Correlator can happen days earlier than it presently does. 24-hour experiment data flow will hopefully follow. The testing of the new communication infrastructure is expected to begin in early 2010.

## 5. Outlook

Once we start flowing real-time data for the daily USNO Intensive experiments in 2010, we hope to build on that start and support 24-hour experiments in (almost) real time as well. If the sustained data rate requirements cannot be met, we will need to set up a buffering system of some sort with the Mark 5 recorder.

A bit farther down the line are plans to run a fiber cable up the mountainside so the data rate needs can be fully met. The local Navy plans to provide a cable as their budget allows.

Construction plans for the antenna base for the QZSS project are in place and should be started shortly. QZSS plans to have their system up and running in 2010.



Figure 3. PEACESAT 7-m antenna.

## Matera CGS VLBI Station

*Giuseppe Bianco, Giuseppe Colucci, Francesco Schiavone*

### Abstract

This report describes the status of the Matera VLBI station. Also an overview of the station, some technical characteristics of the system, and staff addresses are given.

### 1. General



Figure 1. The Matera “Centro di Geodesia Spaziale” (CGS).

The Matera VLBI station is located at the Italian Space Agency’s ‘Centro di Geodesia Spaziale G. Colombo’ (CGS) near Matera, a small town in the south of Italy. The CGS came into operation in 1983 when the Satellite Laser Ranging SAO-1 System was installed at CGS. Fully integrated into the worldwide network, SAO-1 was in continuous operation from 1983 up to 2000, providing high precision ranging observations of several satellites. The new Matera Laser Ranging Observatory (MLRO), one of the most advanced Satellite and Lunar Laser Ranging facilities in the world, was

installed in 2002 and replaced the old SLR system. CGS also hosted mobile SLR systems MTLRS (Holland/Germany) and TLRs-1 (NASA).

In May 1990 the CGS extended its capabilities to Very Long Baseline Interferometry (VLBI), installing a 20-m radiotelescope. Since then, Matera has performed in 813 sessions up through December 2009.

In 1991 we started GPS activities, participating in the GIG 91 experiment and installing at Matera a permanent GPS Rogue receiver. In 1994 six TurboRogue SNR 8100 receivers were purchased in order to create the Italian Space Agency GPS fiducial network (IGFN). At the moment 12 stations are part of the IGFN, and all data from these stations, together with 24 other stations in Italy, are archived and made available by the CGS WWW server GeoDAF (<http://geodaf.mt.asi.it>).

In 2000 we started activities with an Absolute Gravimeter (FG5-Micro-G Solutions). The gravimeter operates routinely at CGS, and it is available for external campaigns on request.

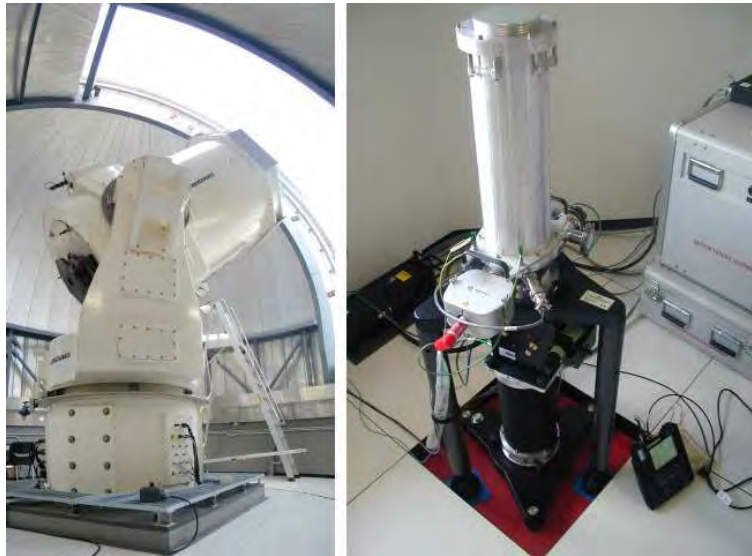

Figure 2. MLRO Telescope and Absolute Gravimeter.

Thanks to the co-location of all precise positioning space based techniques (VLBI, SLR, LLR and GPS) and the Absolute Gravimeter, CGS is one of the few “fundamental” stations in the world. With the objective of exploiting the maximum integration in the field of Earth observations, in the late 1980s ASI extended CGS’ involvement also to remote sensing activities for present and future missions (ERS-1, ERS-2, X-SAR/SIR-C, SRTM, ENVISAT, and COSMO-SkyMed).

## 2. Technical/Scientific Overview

The Matera VLBI antenna is a 20-meter dish with a Cassegrain configuration and an AZ-EL mount. The AZ axis has  $\pm 270$  degrees of available motion. The slewing velocity is 2 deg/sec for both the AZ and the EL axes.

The technical parameters of the Matera VLBI antenna are summarized in Table 1.

The Matera time and frequency system consists of three frequency sources (two Cesium beam



and one H-maser standard) and three independent clock chains. The EFOS-8 H-maser from Oscilloquartz is used as a frequency source for VLBI.

In October 2009, the Mark 5A was updated to run O.S Debian 4.0r3 and Firmware 12.05, as suggested by MIT Haystack.

Table 1. Matera VLBI Antenna Technical Specifications.

Input frequencies	S/X	2210–2450 MHz / 8180–8980 MHz
Noise temperature at dewar flange	S/X	<20 K
IF output frequencies	S/X	190–430 MHz / 100–900 MHz
IF Output Power (300 K at inp. flange)	S/X	0.0 dBm to +8.0 dBm
Gain compression	S/X	<1 dB at +8 dBm output level
Image rejection	S/X	>45 dB within the IF passband
Inter modulation products	S/X	At least 30 dB below each of 2 carriers at an IF output level of 0 dBm per carrier
$T_{sys}$	S/X	55/65 K
SEFD	S/X	800/900 Jy

### 3. Staff

The list of the VLBI staff members of the Matera VLBI station is provided in Table 2.

Table 2. Matera VLBI staff members.

Name	Agency	Activity	E-Mail
Dr. Giuseppe Bianco	ASI	VLBI Manager	giuseppe.bianco@asi.it
Francesco Schiavone	Telespazio	Operations Manager	francesco.schiavone@e-geos.it
Giuseppe Colucci	Telespazio	VLBI contact	giuseppe.colucci@e-geos.it

### 4. Status

In 2009, 53 sessions were acquired. Figure 3 shows the total Acquisitions Summary per year, starting in 1990.

In 2004, in order to fix all the rail problems, a complete rail replacement was planned. In 2005, due to financial difficulties, it was instead decided that only the concrete pedestal under the existing rail would be repaired. From then on, no rail movements have been noted [1]-[3].

In April 2008, due to cracks on the surface, the AZI-1 wheel was replaced by a newly built one. In April 2009, a second wheel was replaced due to the same kind of problem.

In 2008 the process of buying a Mark 5B+ recorder was started, but it hung up because of a lack of CE Marking necessary to import this equipment in Europe.

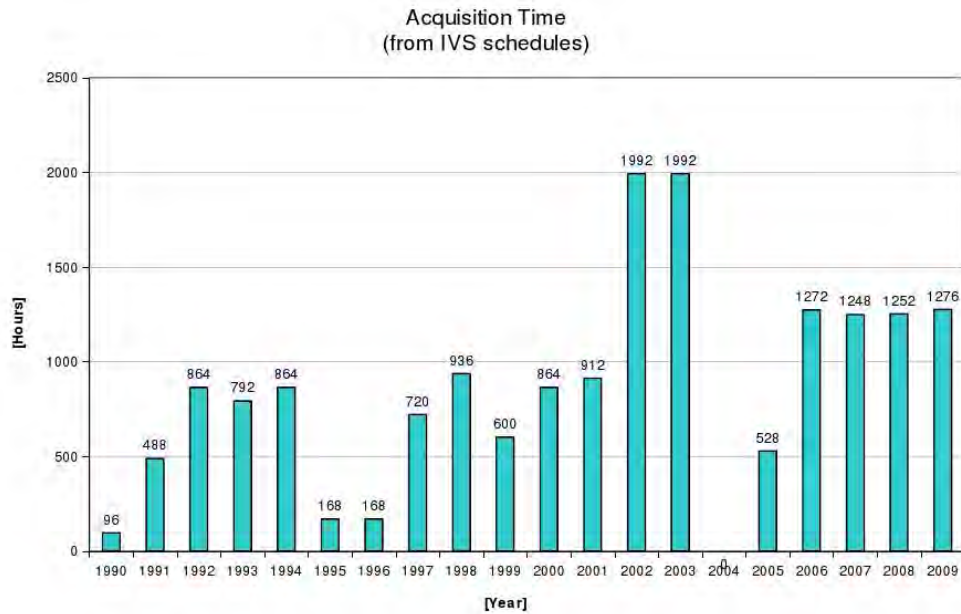

Figure 3. Acquisitions per year.

## 5. Outlook

Negotiation with the builder is in progress in order to get CE Marking on Mark 5B+ and to complete the equipment purchase.

Another goal is to replace the Antenna Control Unit and both Azimuth and Elevation encoders, because it is not possible to find spare parts for these components anymore.

## References

- [1] M. Mannarella “Relazione sulle misure effettuate sulla rotaia dell’antenna VLBI”, Telespazio doc. OT-SPA-SM\_REL\_180010\_1140\_0222, 21/01/2004.
- [2] M. Mannarella “Misure sugli spostamenti indotti sulle piastre e sulla rotaia dell’antenna VLBI”, Telespazio doc. OT-SPA-SM\_REL\_180010\_1320\_0661, 06/04/2005.
- [3] M. Mannarella “Relazione sull’esito dei lavori di ripristino delle parti ammalorate della fondazione dell’antenna VLBI”, Telespazio Doc. OT-SPA-SM\_REL\_180010\_1320\_0732, 27/06/2005.

# The Medicina Station Status Report

*Alessandro Orfei, Andrea Orlati, Giuseppe Maccaferri, Franco Mantovani*

## Abstract

General information about the Medicina Radio Astronomy Station, the 32 m antenna status, and the staff in charge of VLBI observations are provided. In 2009 the data from geodetic VLBI observations were acquired using the Mark 5A recording system with good results. Updates of the hardware have been performed and are briefly described.

## 1. The Medicina 32 m Antenna: General Information

The Medicina 32 m antenna is located at the Medicina Radio Astronomy Station. The station is run by the Istituto di Radioastronomia and is located about 33 km east of Bologna. The Consiglio Nazionale delle Ricerche was the funding agency of the Istituto di Radioastronomia until the end of 2004. Since January 1, 2005 the funding agency has been the Istituto Nazionale di Astrofisica (INAF).

The antenna, inaugurated in 1983, has regularly taken part in IVS observations since 1985 and is an element of the European VLBI network. A permanent GPS station, which is part of the IGS network, is installed in the vicinity. Another GPS system is installed near the VLBI telescope (MSEL) and is part of the EUREF network.

## 2. Antenna Description

The Medicina antenna has Cassegrain optics, consisting of a primary mirror that is 32 m in diameter, and a secondary mirror, called the subreflector, which is of convex shape and about 3 m in diameter. The subreflector, mounted on a quadrupode, is placed opposite the primary mirror and focuses the radio waves at its center, where the receiver system is located. For some observing frequencies, a simplified optical system is enough. The subreflector is therefore shifted from its normal position, and the receiving system is placed at the primary focus. This is the case for the S-X observations. The antenna can operate in the range between 327 MHz and 22 GHz.

The receivers are cooled with cryogenic techniques to improve the system sensitivity. The antenna's operative receiver is easily changed; only a few minutes are needed to change the observing frequency. A recent picture of the antenna is shown in Figure 1.

## 3. The Staff

Many scientists and technicians take care of the observations. However, a limited number are dedicated to maintaining and improving the reliability of the antenna during the observations: Alessandro Orfei is the Chief Engineer, expert in microwave receivers. Giuseppe Maccaferri is the Technician in charge of the telescope's backend, and, in collaboration with Andrea Orlati, Software Engineer, he takes care of the observing schedules and regularly implements SKED, DRUDG, and the Field System.



Figure 1. View of the Medicina 32 m dish taken during geodetic VLBI observations. Note that the subreflector is shifted to allow the use of the S/X receiver located in the primary focus of the radio telescope.

#### 4. Current Status and Activities

A new FS computer was installed in 2009, and the latest Debian release (FS8-Lenny) and the 9.10.4 version of the Field System are running on it.

At present, 33 TB of disk space is available for geodetic observations.

As for receivers, a multifeed system was mounted on the 32 m in 2008. Since then optics alignment has been done, and a pointing model is available. This receiver is intended for SRT, but it will be used on the Medicina antenna until the new telescope will be ready. The feed system was designed to have the best performance in terms of cross-polarization in the VLBI band. VLBI observations were made, and fringes were detected. The multifeed, 14 outputs each 2 GHz wide, is now equipped with a total power back-end able to detect 28 GHz bandwidth with the sampling rate down to 1 msec.

Medicina routinely performs e-VLBI observations at about 1 Gbps.

#### 5. Geodetic VLBI Observations

In 2009 Medicina took part in 24 (24 hour) routine geodetic sessions (namely 2 IVS-T2, 13 IVS-R4, 4 IVS-R1, 3 EUROPE, and 2 R&D experiments).

# VERA Geodetic Activities

*Seiji Manabe, Takaaki Jike, Yoshiaki Tamura, Makoto Shizugami, VERA group*

## Abstract

Geodetic activities of VERA in the year 2009 are briefly described. The regular geodetic observations are carried out both in K- and S/X-bands. The frequency of regular observations is three times a month—that is, twice for the VERA internal observations in K-band and once in S/X-band. The S/X sessions are GSI's JADE sessions until August and IVS-T2 sessions starting in September, whenever the IVS-T2 sessions are scheduled. The raw data of the T2 sessions are electronically transferred to the Bonn and Haystack correlators via the Internet using the Tsunami protocol.

Delays, delay rates, and other relevant data of the S/X sessions through the end of 2009 were disclosed and submitted to IVS.

Gravimetric observations are carried out at the VERA stations. The super conducting gravimeter previously installed at Esashi Earth Tides Station was moved to Mizusawa and placed in the vicinity of the VERA antenna in order to monitor vertical displacement at the end of 2008, and observations continued throughout 2009.

## 1. General Description

VERA is a Japanese domestic VLBI network consisting of the Mizusawa, Iriki, Ogasawara, and Ishigakijima stations. Each station is equipped with a 20-m radio telescope and a VLBI back-end. The Ishigakijima antenna is shown in figure 1. The VERA array is controlled from the Array Operation Center at Mizusawa via the Internet.

The primary scientific goal of VERA is to reveal the structure and the dynamics of our galaxy by determining its three-dimensional force field and its distribution of mass. Galactic maser sources are used as dynamical probes, whose positions and velocities can be precisely determined by phase referenced VLBI relative to extragalactic radio sources. The distance is measured as a classical annual trigonometric parallax. The observing frequency bands of VERA are S and X, K (22 GHz) and Q (43 GHz). Geodetic observations are made in S/X- and K-bands. Q-band is currently not used for geodesy. Only a single beam is used even in K-band in geodetic observations, although VERA can simultaneously observe two closely separated radio sources ( $0.2^\circ < \text{separation angle} < 2.2^\circ$ ) by using the dual beam platforms.

General information about the VERA stations is summarized in Table 1, and their geographic locations are shown in Figure 2. The lengths of their baselines range from 1000 km to 2272 km. The horizon west of at the Ogasawara station ranges from  $7^\circ$  to  $18^\circ$  because it is located at the bottom of an old volcanic crater. The northeast sky at the Ishigakijima station is blocked by a nearby high mountain. However, most of the sky is visible to below  $9^\circ$ . The horizon at Mizusawa and Iriki are low enough to observe sources with low elevation. Since Ogasawara and Ishigakijima are small islands in the open sea and their climate is subtropical, the humidity in the summer is very high. This causes a high system temperature in the summer, in particular in the K and Q bands. The Iriki station, as well as the other stations, is frequently hit by strong typhoons. The wind speed sometimes reaches 60–70m/s.



Figure 1. VERA Ishigakijima antenna

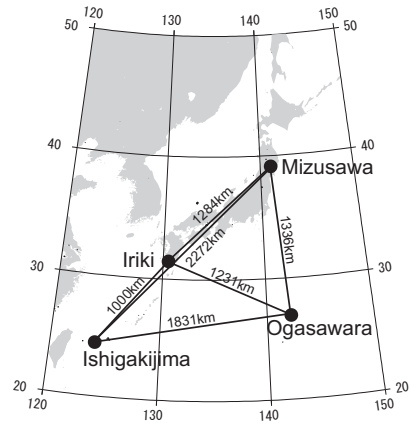

Figure 2. Location of the VERA stations

Table 1. General information

Sponsoring agency	Mizusawa VLBI Observatory, National Astronomical Observatory of Japan		
Contributing type	Network observing station		
Location	Mizusawa	141° 07' 57".199E, 39° 08' 00".726N, 75.7m (sea level)	
	Iriki	130° 26' 23".593E, 31° 44' 52".437N, 541.6m (sea level)	
	Ogasawara	142° 12' 59".809E, 27° 05' 30".487N, 223.0m (sea level)	
	Ishigakijima	124° 10' 15".578E, 24° 24' 43".834N, 38.5m (sea level)	

## 2. Technical Parameters

Parameters of the antennas and their front- and back-ends are summarized in Tables 2 and 3, respectively. Two observing modes are used in geodetic observing. One is the VERA internal K-band observing mode with a recording rate of 1 Gbps. The other is the conventional S/X-band observing mode with K5-VSSP. JADE, which is GSI's domestic observation project, and IVS-T2 sessions belong to this class. Only Mizusawa and Ishigakijima participated in these sessions.

Table 2. Antenna parameters

Diameter	20m	Slew	Azimuth	Elevation
Mount	Az-El	range	-90° – 450°	5° – 85°
Surface accuracy	0.2mm (rms)	speed	2°/sec	2°/sec
Pointing accuracy	<12" (rms)	acceleration	2°/sec <sup>2</sup>	2°/sec <sup>2</sup>
	S	X	K	
HPBW	1550"	400"	150"	
Aperture efficiency	0.25	0.4	0.47	

Table 3. Front-end and back-end parameters

Front-end					
Frequency band	Frequency range (GHz)	Receiver temperature	Polarization	Receiver type	Feed
S	2.18–2.36	100°K	RHC	HEMT	Helical array
X	8.18–8.60	100°K	RHC	HEMT	Helical array
K	21.5–24.5	39±8°K	LHC	HEMT(cooled)	Horn
Back-end					
Type	channels	BW/channel	Filter	Recorder	Deployed station
VERA	16	16 MHz	Digital	DIR2000	4 VERA
K5-VSSP	16	4 MHz	VC	HDD	Mizusawa Ishigakijima

### 3. Organizational Change and Staff Members

The Mizusawa VERA Observatory of NAOJ was reorganized as the Mizusawa VLBI Observatory in April, 2009. VERA and VSOP-2 were integrated into a unified project. The director is Hideyuki Kobayashi. The geodesy group consists of S. Manabe (chief, scientist), Y. Tamura (scientist), T. Jike (scientist), and M. Shizugami (software technician).

### 4. Current Status and Activities

#### 4.1. VLBI

VERA observes six days a week, except for a maintenance period in the summer. The nominal frequency of geodetic observations is three days a month. Among these three days, VERA internal geodetic observations in K-band are performed twice a month, and Mizusawa and Ishigakijima participate in GSI's JADE sessions or in the IVS-T2 sessions in S/X-band once a month. The main purpose of the VERA internal geodetic observations is to determine the relative positions of the VERA antennas accurately enough for astrometric requirements. The purpose of the S/X sessions is to integrate VERA's coordinates into the global reference frame. The reason for shifting the observing frequency band from S/X-band to K-band is to avoid strong radio interference created in S-band by cellular phones, particularly at Mizusawa. Interfering signals, which have line spectra, are filtered out. However, this filtering considerably degrades the system noise temperature. It is likely that S-band observations will become impossible in the near future. On the other hand, VERA has the highest sensitivity in K-band as shown in Table 3. Thanks to the high sensitivity in this band the maximum number of scans in K-band is 750 per station every 24 hours, while that in S/X-band is at most 500. It has been confirmed that the K-band observations are far more precise, although no correction is made for the ionospheric delay. In fact, standard deviations of the individual determinations of the antenna positions in K-band are less than half of those in S/X-band.

The error ellipsoid is fairly elongated in the vertical direction due to the insufficient network

size for separating the vertical displacement from the zenith atmospheric delay variation. No significant systematic differences between the estimated coordinates in S/X-band and the estimated coordinates in K-band seem to exist. This means that most of the ionospheric effect can be eliminated in the course of estimating the tropospheric delay, at least for the VERA network, whose typical size is around 2300 km. However, the number of observations are not enough to derive a definite conclusion.

In order to link the VERA network to the international reference frame VERA started participation in the IVS-T2 sessions by using the Mizusawa and the Ishigakijima stations. The observations at Ishigakijima were conducted by GSI. In September, 2009, we successfully made a test of observing and transferring the data electronically to the Haystack correlator via the Tsunami protocol. Since October, we participated in the T2 sessions twice. The T2 sessions replace the JADE sessions whenever the T2 sessions take place.

The final estimation of the geodetic parameters is performed by using software developed by the VERA team.

From December 2004 to July 2008, 54 S/X-band data sets were submitted to IVS in the form of PIVEX.

## 4.2. Other Activities

Continuous GPS observations were carried out at each VERA station throughout the year. The observation of gravity tides with a LaCoste-Romberg gravimeter at Ogasawara has been completed, and that at Ishigakijima is underway. The provisional result shows that there is no large discrepancy between the observed tidal amplitude and phase and the tidal amplitude and phase predicted by ocean models.

The superconducting gravimeter was moved from the Esashi Earth Tides Station to Mizusawa in order to accurately monitor gravity change for the purpose of monitoring height change at VERA Mizusawa station. Four water table gauges surrounding the SCG were used for monitoring the water table height. The preliminary results show that gravity variation due to the variation of the water table can be corrected to  $1\mu\text{gal}$  level accuracy.

## 5. Future Plans

The internal K-band VLBI and the participation in the IVS-T2 sessions will be continued. Continuous GPS and gravimetric observations will also be carried out. Reconfirmation of local ties between GPS and VLBI has become an urgent task.

The possibility of optical fiber links between Mitaka and the VERA stations is being pursued. Widening of the receiving and recording bandwidth is planned.



# Noto Station Status Report

*G. Tuccari*

## Abstract

This brief report summarizes the main activities of the Observatory of Noto in 2009.

## 1. Antenna, Receivers and Microwave Technology

In the second half of the year, the antenna driving system was damaged, and the operations were stopped for about three months. The motor drivers and encoders were replaced, and normal observing resumed. This problem had appeared at other times, and the cause could possibly be related to the ground potential level between the antenna area and the drive cabinet. Further analysis is necessary, and a specialized electrical company will be contacted as soon as dedicated funds become available.

The 86 GHz receiver was repaired at MPI in Bonn, and now some modifications to the mechanical structure are going ahead. The receiver will be tested in the antenna during the first months of 2010.

## 2. Acquisition Terminal

A complete DBBC system that will be used with an additional Mark 5C/B+ in both modes is available. Regular observations will be performed in 2010 in parallel with the analog terminal in order to have a soft migration between the two systems. As soon as the digital terminal becomes fully operational, the Mark 5A will be converted to a Mark 5B, and a second DBBC will be installed at the station.

The Mark 5C is supported in the DBBC by the Fila10G interface and the Glapper board that converts the stream coming in optical fiber from the Fila10G in the copper CX4. Figure 1 shows an image of the Fila10G; Figure 2 shows the Glapper board; and Figure 3 shows the new Mark 5C at Noto.

## 3. DBBC Status Report

The DBBC hardware stack can handle the Tunable and Multi-Equi-Spaced Channel configurations because of its programmability and its flexibility in the number of elements it can adopt. Two types of sampler boards are available with a total bandwidth of 512 or 1024 MHz, and they can be selected in a maximum number of four aggregate IFs for a group of processing boards. A single Core2 processing board is able to produce either four tunable BBCs or fifteen equi-spaced 16 MHz channels.

Two operation modes are possible at present:

The Digital-Down-Converter configuration generates 16 x 1-16 MHz wide tunable bands. The implementation emulates an analog VLBI down-converter system, with independent channels in bandwidth and tuning base. Each Core2 board is able to produce four BBCs.

The Multichannel Equi-spaced configuration generates 16 x 32 MHz wide bands. The implementation is realized by adopting the intrinsic capability of a highly efficient DFT processor to

down-convert in base band contiguous slices of band. The single DFT operation presents poor frequency rejection between adjacent channels, so a preliminary filter is adopted to greatly improve the separation performance.

A continuous program is underway to develop possible upgrades. This mainly involves:

- 10G connections with the FILA10G and Glapper boards;
- A 2 GHz bandwidth sampler with the ADB3 aggregate module;
- Digital pre-processing and very high performance capabilities with the Core3 board;
- Development of the DBBC2010, a DBBC version designed to fulfill the VLBI2010 demand for a backend in terms of number of IFs and observational capability.

The spin-off company HAT-Lab has been fully operational since September 2009, and several systems are under construction. The time frame for the delivery of the first batch of seven units is February/March 2010. A second batch will be started in April. The collaboration between HAT-Lab, IRA and MPI for realizing the DBBC is ongoing.

#### 4. Geodetic Observations in 2009

During 2009, the Noto station participated in six geodetic experiments: EURO97, T2060, EURO98, T2062, IYA09, and EURO102.

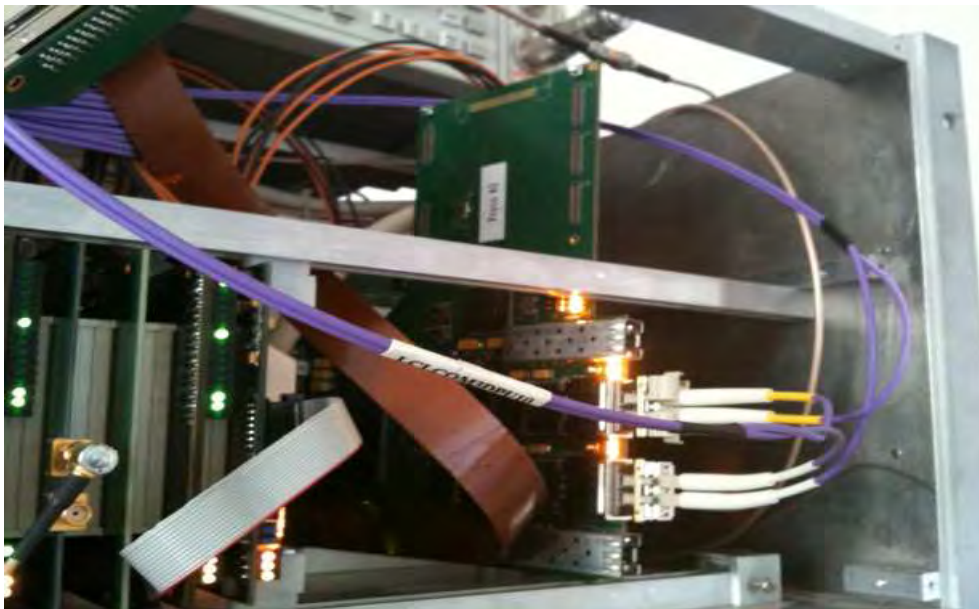

Figure 1. Fila10G interface



Figure 2. Glapper board



Figure 3. Mark 5C

# Ny-Ålesund 20-meter Antenna

*Carl Petter Nielsen*

## Abstract

For the year 2009, the 20-meter VLBI antenna at the Geodetic Observatory, Ny-Ålesund, has participated in VLBI experiments, observing 78 of 80 scheduled 24-hour experiments and 42 of 44 scheduled Intensives. Reasons for the lost experiments were encoder problems and loss of Internet connection. Several experiments during February had to be run with a warm receiver due to a combination of bad weather and compressor problems. In 2009, Ny-Ålesund was a three-person station with Ole Bjørn Årdal as station commander working full time, and Carl Petter Nielsen and Geir Mathiassen working 75% as engineers. In August Moritz Sieber became the third engineer also working 75%. Ole Bjørn Årdal decided to end his employment with the NMA just before Christmas. The new base commander will be Carl Petter Nielsen, and a new engineer will hopefully start early in 2010. Ny-Ålesund is a Mark 5A station.

## 1. General Information

The Geodetic Observatory of the Norwegian Mapping Authority (NMA) is situated at 78.94 N and 11.87 W in Ny-Ålesund, in Kings Bay, at the west side of the island of Spitsbergen. This is the biggest island in the Svalbard archipelago. In 2009, Ny-Ålesund was scheduled for 80 24-hour VLBI experiments, including R1, R4, EURO, RD, T2, and RDV sessions, and 44 Intensives within the INT3 program. Four experiments had to be cancelled because of station problems. Original problems were encoder and loss of network. Then bad weather conditions before, during, or after repair, making it impossible to work outdoors, often prolonged the downtime period.

In addition to the 20-meter VLBI antenna, the Geodetic Observatory has two GPS antennas in the IGS system and a Superconducting Gravimeter in the Global Geodynamics Project (GGP) installed at the site. There is also a CHAMP GPS and a SATREF (dGPS) installation at the station. At the French-German research station in Ny-Ålesund, there is a DORIS station. In October 2004, a GISTM (GPS Ionospheric Scintillation and TEC Monitor) receiver was installed at the Statens Kartverk structure in the frame of ISACCO, an Italian research project on ionospheric scintillation observations, led by Giorgiana De Franceschi of the Italian Institute of Volcanology and Geophysics (INGV).

## 2. Component Description

The antenna is intended for geodetic use and is designed for receiving in S-band and X-band. Ny-Ålesund is a Mark 5A-only station. The station configuration file can be found on the IVS Web site: <ftp://ivsc.gsfc.nasa.gov/pub/config/ns/nyales.config>. Ny-Ålesund's close proximity to the North Pole means that the sun is below the horizon from the 23rd of October until the 22nd of February and is above the horizon from 20th April to 27th August. It also means that the station has a large number of circumpolar sources and is situated underneath the auroral oval between 06:00 and 13:00.

### 3. Staff

Ole Bjørn Årdal was the station commander during 2009 and ended his employment at the end of the year. Carl Petter Nielsen and Geir Mathiassen both have a 3-year part-time contract as engineers. They will work three months followed by one month of leave. In August Moritz Sieber was employed as a part time engineer.

Table 1. Staff related to VLBI operations at Ny-Ålesund. All e-mail addresses are @statkart.no; phone numbers are prefixed in Hønefoss with +47-321- and in Ny-Ålesund with +47-7902-.

Location	Function	Name	e-mail	phone
Hønefoss	Section manager	Line Langkaas	line.langkaas	18434
Ny-Ålesund	Station commander	Ole Bjørn Årdal	ole-bjorn.ardal	
	Engineers	Geir Mathiassen	geir.mathiassen	7010
		Carl Petter Nielsen	carl-petter.nielsen	
		Moritz Sieber (2009.08-)	moritz.sieber	



Figure 1. Ny-Ålesund geodetic observatory, staff (Moritz Sieber, Carl Petter Nielsen, and Geir Mathiassen) and antenna, seen from the west.

### 4. Current Status and Activities

Ny-Ålesund participated in the scheduled VLBI experiments. During 2009 e-VLBI was used for transferring R1 and INT3 measurements from Ny-Ålesund to the Bonn correlator.

The Superconducting Gravimeter (SCG) placed on the same foundation as IGS-GPS NYA1 has been running without problems. The annual service on the system was performed by Ove

Omang and Carl Petter Nielsen at the end of September. National Astronomical Observatory of Japan, Mizusawa VERA Observatory, which owns the SCG, lent this equipment to NMA starting 2007.04.01, to continue the scientific measurement series.

A consultant checked the indoor climate and found it satisfactory after the repair in 2008. Some adjustments were done to the roof to stop a minor leakage.

Ed Himwich, Brian Corey, and Rich Strand visited the station in July to educate the new staff and monitor the development of the station. The new Field System computers were installed.

Rüdiger Haas and Sten Bergstrand visited the station in late June and set up a system for monitoring the local movements in the ground.

In connection with an application for the financing of two new antennas, a radar profile of ground conditions near by has been made with a ground radar borrowed from The University Centre in Svalbard (UNIS). Based on this background, a decision to drill a number of holes at some locations was made. The purpose of this is to establish the ground condition for possible antenna sites. As soon as the ground freezes and is covered with snow, Kings Bay will start the drilling.

## 5. Future Plans

Ny-Ålesund will continue to participate in 83 regular and 45 Intensive experiments for which the antenna is scheduled. Carl Petter Nielsen will be the station commander from the 1st of February, and Lars Karvonen will start as a new engineer on the same date. Our hope is that the application for two new antennas will come through, in which case some work with planning and road construction will start. If not, a new and improved application will be made, with some involvement of the station staff.

To reduce loss of energy, the insulation in the roof of the observatory has to be improved. This will hopefully happen during the summer of 2010. Painting of the observatory and some other buildings is planned as well.

# German Antarctic Receiving Station (GARS) O'Higgins

*Christian Plötz, Reiner Wojdziak, Richard Kilger, Alexander Neidhardt*

## Abstract

In 2009 the German Antarctic Receiving Station (GARS) in O'Higgins contributed to the IVS observing program with 10 observation sessions. General maintenance of the dewar was done. A newly installed Leica GPS receiver is now ready for Galileo. The remote control tests with the software specially developed at Wettzell were continued for VLBI sessions.

## 1. General Information

The German Antarctic Receiving Station (GARS) is jointly operated by the Federal Office of Cartography and Geodesy (BKG, where it is part of the duties of the Geodetic Observatory Wettzell (GOW)) and the German Aerospace Center (DLR). The Institute for Antarctic Research Chile (INACH) coordinates the activities and logistics. The 9-m radio telescope at O'Higgins is used for geodetic VLBI and for downloading of remote sensing images from satellites like ERS-2 and TerraSAR-X as well as commanding and monitoring spacecraft telemetry. The access to the station is still organized campaign-wise during the Antarctic spring and summer. In 2009 the station was occupied from January to March and from October to December. DLR and BKG jointly sent engineers and operators for the campaigns, together with a team for the infrastructure (e.g., the power generator).

Over recent years, special flights with "Hercules C-130" and small "Twin Otter DHC-6" aircraft were organized by INACH in close collaboration with the Chilean Army, Navy, and Airforce and with the Brazilian and Uruguayan Airforce in order to transport the staff, the technical material, and also the food for the entire campaign from Punta Arenas via Base Frei at King George Island to O'Higgins on the Antarctic Peninsula. Another route uses transportation by ship to and from O'Higgins. Due to the fact that the conditions for landing on the glacier have become unpredictable and require a lot of security precautions, the usage of a ship for transportation to O'Higgins has become more and more important. As a consequence of global warming, the glacier melts. During the summer period, transport of personnel and cargo becomes more and more difficult. Arrival and departure times are strongly dependent on the weather conditions and on the general logistics.

After the long Antarctic winter, usually the equipment at the station has to be initialized. Damages, which result from the strong winter period or strong storms, have to be identified and repaired. Shipment of spare parts or material for upgrades from Germany have to be carefully prepared in advance.

The 9-m radio telescope for VLBI is co-located with:

- two GPS receivers operated in the frame of IGS all year. The receivers worked without failure in 2009.
- plans for a new radar tide gauge went ahead. The installation was shifted to 2010. The radar sensor itself will be position-calibrated by a GPS antenna mounted on the top of the radar sensor unit.
- a meteorological station providing pressure, temperature, and humidity and wind information, as long as the extreme conditions outside did not disturb the sensors. High wind speeds

and ice uploads caused damage in 2009 so that parts of the meteorological site had to be replaced.

- a H-Maser, an atomic Cs-clock, a GPS time receiver, and a Total Accurate Clock (TAC) offer time and frequency.
- a defective underwater sea level gauge will be replaced for permanent monitoring of temperature, tide pressure, and salinity of the sea water.

The 9-m radio telescope is designed for dual purpose:

- performing geodetic VLBI and
- receiving the remote sensing data from LEO-satellites, mainly from ERS-2, TerraSAR-X.



Figure 1. GARS O'Higgins taken by a Web cam which is mounted on top of the containers



Figure 2. The penguin colony directly behind the station



## 2. Technical Staff

The staff members for operation, maintenance, and upgrade of the GARS VLBI components and the geodetic devices are summarized in Table 1.

Table 1. Staff – members

Name	Affiliation	Function	Working for
Christian Plötz	BKG	electronic engineer	O'Higgins (responsible), RTW
Reiner Wojdziak	BKG	software engineer	O'Higgins, IVS Data Center Leipzig
Richard Kilger	FESG	mechanical engineer	O'Higgins (for campaign operations)
Alexander Neidhardt	FESG	head of the RTW group and VLBI station chief	RTW, SOSW (partly O'Higgins)
Gerhard Kronschnabl	BKG	electronic engineer	RTW (maintenance in Wettzell)
Johannes Ihde	BKG	interim head of the GOW (until June 2009)	GOW
Ullrich Schreiber	BKG	head of the GOW (July to December 2009)	GOW

## 3. Observations in 2009

GARS participated in the following sessions of the IVS observing program during the Antarctic summer campaign (January-March 2009)

- IVS-T2060, February 03-04, 2009
- IVS-OHIG62, February 04-05, 2009
- IVS-OHIG63, February 10-11, 2009
- IVS-OHIG64, February 11-12, 2009
- TANAMILBA2, V252K February 23-24, 2009
- TANAMILBA3, V252L February 27-28, 2009

and during the Antarctic spring campaign (October-December 2009)

- IVS-OHIG65, November 10-11, 2009
- IVS-OHIG66, November 11-12, 2009
- IVS-T2065, November 17-18, 2009
- IYA2009SS, November 18-19, 2009

The observations were recorded with Mark 5A. The data were carried from O'Higgins to Punta Arenas by the staff when they returned home. From Punta Arenas, the disks were shipped by regular air transport to the correlator in Bonn, Germany. The TANAMI observations are correlated at Curtin University of Technology, Australia. The IYA2009 session is correlated in Haystack, USA.

## 4. Maintenance

The extreme conditions in the Antarctic require special attention to the GARS telescope and to the infrastructure. Frequently corrosion results in problems with connectors and capacitors, which need to be detected. The antenna, the S/X-band receiver, the cooling system, and the data acquisition system have to be activated properly. To continue the high quality of observations

at GARS, the cryo-system was maintained. Therefore the dewar was revised at the GOW where structural improvements could be realized in the internal setup. After this work the dewar was installed again in O'Higgins during the Antarctic spring campaign (October-December 2009).

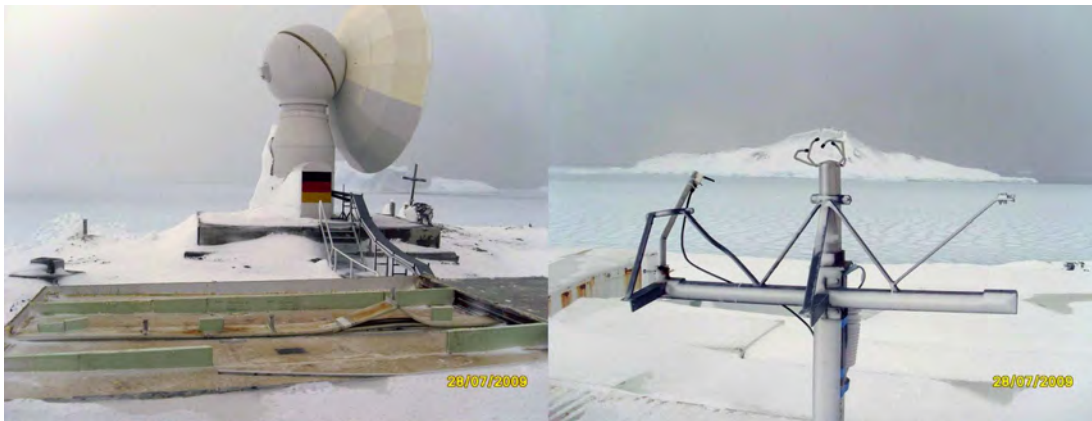

Figure 3. The destructions caused by a strong storm: unroofed containers and a totally damaged meteorological site

Those components which were damaged during the previous campaign or because of the extreme conditions were replaced. Therefore the meteorological station had to be partly replaced. A new wind sensor was installed due to the destruction of the previous one during storm conditions between the campaigns. The satellite communication antenna and therefore the Internet and phone connection were improved. The failed up-converter, which was temporarily operative by using an external signal generator, could be brought back to full functionality after maintenance in Wettzell.

## 5. Technical Improvements

Remote control of complete VLBI sessions could be extended. With the newly developed software from Wettzell, the O'Higgins Field System can be controlled over a secure Internet connection from Wettzell. This is a key feature for extended operation periods in GARS O'Higgins.

In addition a new Leica antenna which is now able to receive Galileo was installed.

## 6. Upgrade Plans for 2010

It is planned to install the radar tide gauge directly on shore. A sea level tide gauge is planned to be re-installed. Additionally a new communication antenna setup, capable of up to 8 Mbit/s, is going to extend bandwidth for data transmission as a peer-to-peer connection between O'Higgins and Oberpfaffenhofen, Germany. The GARS station will be open continuously in 2010 for a planned period of five years, because of the Tandem-X Mission. This extends significantly also the operation period of IVS VLBI measurements. In addition, to keep the productivity, it is planned to develop a spare dewar system fitting directly into cryo-system at GARS antenna.

# Onsala Space Observatory – IVS Network Station

*Rüdiger Haas, Gunnar Elgered, Johan Löfgren, Hans-Georg Scherneck*

## Abstract

During 2009 the Onsala Space Observatory contributed as an IVS Network Station to 24 VLBI sessions organized by the IVS. We used four of these sessions to do ultra-rapid dUT1 observations together with our colleagues in Tsukuba. This report briefly summarizes the activities during the year 2009.

## 1. Staff Associated with the IVS Network Station at Onsala

There were some changes concerning the staff associated with the IVS Network Station at Onsala during 2009. One new PhD. student joined the Space Geodesy and Geodynamics group and is involved in geodetic VLBI. On the other hand, one post-doc left, and one software engineer retired. One new telescope scientist and one new software engineer started during 2009.

Table 1. Staff associated with the IVS Network Station at Onsala. All e-mail addresses have the ending @chalmers.se and the complete telephone numbers start with the prefix +46-31-772.

Function	Name	e-mail	telephone
Responsible P.I.	Rüdiger Haas	rudiger.haas	5530
Observatory director	Hans Olofsson	hans.olofsson	5520
Head of department	Gunnar Elgered	gunnar.elgered	5565
PhD. students	Tobias Nilsson (– 2009.04.30)	tobias.nilsson	5575
and post-docs	Tong Ning	tong.ning	5578
involved in GEO-VLBI	Johan Löfgren	johan.lofgren	5566
Responsible for	Michael Lindqvist	michael.lindqvist	5508
the Field System	Rüdiger Haas	rudiger.haas	5530
Responsible for the	Karl-Åke Johansson	karl-ake.johansson	5571
VLBI equipment	Leif Helldner	leif.helldner	5576
VLBI operator	Roger Hammargren	roger.hammargren	5551
Telescope scientists	Per Bergman	per.bergman	5552
	Henrik Olofsson (2009.11.01 –)	henrik.olofsson	5564
Software engineers	Lars Lundahl (– 2009.12.31)	lars.lundahl	5559
	Mikael Lerner (2009.06.01 –)	mikael.lerner	5581

## 2. Geodetic VLBI Observations for the IVS during 2009

In 2009 the Onsala observatory was involved in the four IVS series EUROPE, R1, T2, and RD09, and additionally contributed to the IYA09 very large astrometry session. In total, Onsala participated and acquired useful observations in 24 experiments; see Table 2. All experiments were recorded on Mark 5 modules. Most of the experiments whose data were correlated at the Bonn correlator were additionally recorded in parallel on the PCEVN-computer that is daisy-chained to the Mark 5 computer. The observed data of these experiments were then e-transferred using the

Table 2. Geodetic VLBI experiments at the Onsala Space Observatory during 2009.

Exper.	Date	Remarks	Correlated
R1-361	JAN.12	e-transfer to Bonn	o.k.
R1-363	JAN.26	20 min lost at start, e-transfer to Bonn	o.k.
RD-0904	FEB.23	module shipment to Haystack	o.k.
R1-372	MAR.30	e-transfer to Bonn	o.k.
T2-061	APR.07	e-transfer to Bonn	o.k.
RD-0906	APR.15	20 min lost due to Mark 5 problems, module shipment to Haystack	o.k.
R1-377	MAY.04	e-transfer to Bonn	o.k.
EUR-099	MAY.25	e-transfer to Bonn	o.k.
R1-380	MAY.26	e-transfer to Bonn	o.k.
R1-385	JUN.29	14 scans lost due to overheated antenna PSU, e-transfer to Bonn	o.k.
R1-386	JUL.06	e-transfer to Bonn	o.k.
RD-0907	JUL.08	module shipment to Haystack	o.k.
R1-393	AUG.24	e-transfer to Bonn	o.k.
EUR-101	SEP.07	e-transfer to Bonn	o.k.
R1-397	SEP.21	e-transfer to Bonn	o.k.
RD-0908	SEP.23	module shipment to Haystack	o.k.
R1-399	OCT.05	module shipment to Bonn	o.k.
RD-0909	OCT.06	module shipment to Haystack	o.k.
IYA09	NOV.18	12 hours only, module shipment to Haystack	not yet
R1-406	NOV.23	e-transfer to Bonn	o.k.
EUR-102	NOV.26	e-transfer to Bonn	o.k.
R1-409	DEC.14	e-transfer to Bonn	o.k.
RD-0910	DEC.16	module shipment to Haystack	o.k.
R1-410	DEC.21	ca. 30 min. missed due to Mark 5 problems, e-transfer to Bonn	o.k.

Tsunami-protocol, and no Mark 5 modules were actually sent to Bonn. During 2009 the PCEVN raid-system was upgraded to a capacity of 4 Gigabytes.

Radio interference due to UMTS mobile telephone signals continued to be a disturbing factor for the S-band observations.

### 3. Fennoscandian-Japanese Ultra-rapid dUT1 Measurements

We continued our involvement in the successful Fennoscandian-Japanese ultra-rapid dUT1 project. The aim for 2009 was to extend the approach with real-time data transfer and automated near real-time correlation and dUT1 analysis to complete 24-hour sessions. Only a small number of such sessions was performed using standard IVS sessions that involved both Onsala and Tsukuba; see Table 3. The highlights were two sessions in December 2009 with continuous determination of dUT1 results during the ongoing VLBI observations using a ‘sliding window’ of ca. 30 scans.

Table 3. Fennoscandian-Japanese 24-h ultra-rapid dUT1-experiments in 2009.

Exper.	Date	Stations	Mbps	Transfer	Correlation	Comments
R1-385	JUN.29	Onsa-Tsuk	256	real-time	real-time	partly successful
RD-0907	JUL.08	Onsa-Tsuk	256	real-time	real-time	partly successful
R1-409	DEC.14	Onsa-Tsuk	256	real-time	real-time	continuous dUT1 during 24 h
RD-0910	DEC.16	Onsa-Tsuk	256	real-time	real-time	continuous dUT1 during 24 h

#### 4. Monitoring Activities in 2009

Monitoring activities were continued as described in previous annual reports. This included the calibration of the Onsala pressure sensor using a Vaisala barometer borrowed from the Swedish Meteorological and Hydrological Institute (SMHI). This instrument has been installed at Onsala in late 2002 and has been calibrated at the SMHI main facility in Norrköping every 1–2 years since then.

Figure 1 shows the differences between the Vaisala (SMHI) pressure sensor and the pressure sensors used for the VLBI system. Since the beginning of 2008 the VLBI system has used a new Vaisala pressure sensor instead of the old Setra pressure sensor. The clear annual signal in the pressure differences disappears at the beginning of 2008. This indicated that the old sensor obviously suffered from a small systematic error, probably due to an unwanted temperature dependence.

The amplitude of this annual term is, however, small and can be neglected in all applications when the atmospheric effect is solved for in the data analysis. A pressure error of 1 hPa corresponds to an error of 2.3 mm in the Zenith Hydrostatic Delay (ZHD), and hence also in the Zenith Wet Delay (ZWD), which in turn is equivalent to an error of 0.35 kg/m<sup>2</sup> in the atmospheric Integrated Water Vapor (IWV). On the other hand, for the application of using VLBI to estimate long time series of the IWV, systematic effects of this size must be monitored in order to not affect estimated long-term trends.

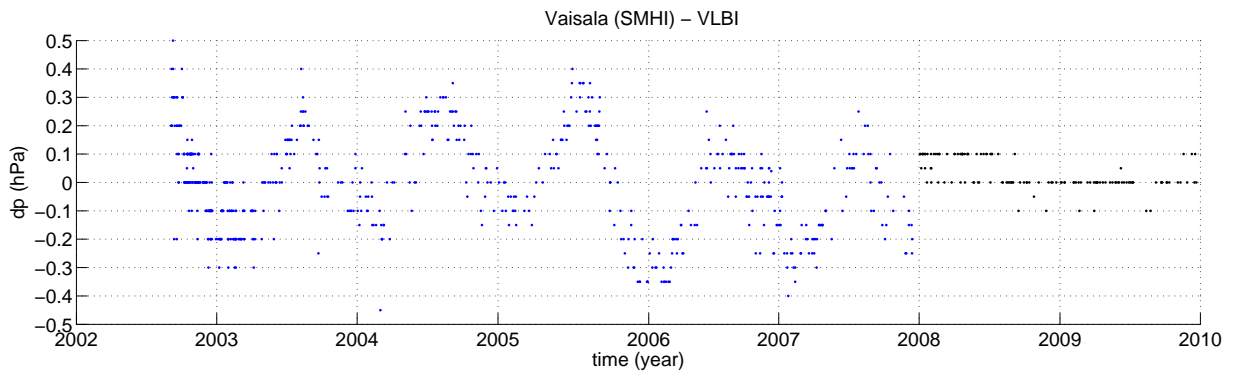

Figure 1. Time series of pressure differences between the Vaisala (SMHI) pressure sensor and the pressure sensors used for VLBI.

We also continued to monitor the vertical height changes of the telescope tower using the invar rod system at the 20 m telescope.

## 5. Gravimetry

In June 2009 a superconducting gravimeter was installed and taken into operation at the observatory. With this installation Onsala has become a true Fundamental Geodetic Station providing observations of the three pillars of geodesy, i.e. earth deformation, earth rotation, and the earth's gravity field. In connection with the superconducting gravimeter, a number of auxiliary sensors, e.g. to monitor ground water variations, will be installed in the near future.

## 6. The GNSS-based Tide Gauge

Encouraged by the first experimental results of a GNSS-based tide gauge, we decided to design a more permanent installation. We identified an appropriate location at the coast at the Onsala Space Observatory that has open sea towards the southward direction. This will maximize the potential reflection area on the sea surface. We designed an installation that will allow control of the vertical position of the GNSS antennas above the sea surface and will allow easy maintenance of the instrumentation. The necessary material was purchased, and the production of the installation equipment has started.

## 7. Evaluation of the Observatory

During 2009 the Swedish Research Council (VR) carried out an international evaluation of the activities at Onsala Space Observatory. The result of this evaluation was quite positive, and the evaluation committee wrote that the observatory “is fulfilling an important function in Sweden both in promoting research, in rearing a new generation of astronomers, geodesists, geophysicists and engineers, and in providing a focal point for Swedish national interests in various areas of astronomy and geodesy. In essence, OSO is helping to keep Sweden at the forefront of modern research and to provide the new generation of Swedish scientists.” The committee recommended that the geodesy and geophysics activities, so far made on a “best effort” basis, should officially be incorporated into the observatory mission.

## 8. Outlook

The Onsala Space Observatory will continue to operate as an IVS Network Station and to participate in the IVS observation series. At the moment a total of 26 experiments is planned for the year 2010 in the EUROPE, R1, T2, and RD10 series. We are already discussing a potential increase of observing sessions for the second half of 2010. As in the previous years we aim to e-transfer the data of as many experiments as possible.

We will also continue the Fennoscandian-Japanese ultra-rapid dUT1-project. As in 2009, the focus will be on 24-h Intensive type ultra-rapid dUT1 sessions during regular IVS sessions.

# Sheshan VLBI Station Report for 2009

*Xiaoyu Hong, Qingyuan Fan, Tao An, Bo Xia*

## Abstract

This report summarizes the observing activities at the Sheshan station (SESHAN25) in 2009. It includes the international VLBI observations for astrometry, geodesy, and astrophysics and domestic observations for satellite monitoring. We also report on updates, and development of the facilities at the station.

## 1. General Information

The Sheshan VLBI station (“SESHAN25”) is hosted by the Shanghai Astronomical Observatory (SHAO), Chinese Academy of Sciences (CAS). A 25-meter radio telescope is in operation at 1.3, 3.6/13, 5, 6, and 18 cm wavelengths. The Sheshan VLBI station is a member of the IVS, EVN, and APT. The telescope takes part in international VLBI experiments on astrometric, geodetic, and astrophysical research. Together with three other radio telescopes in China, the Sheshan radio telescope participates in the VLBI tracking of spacecraft such as the Chinese Chang’E-1 satellite.

## 2. VLBI Observations in 2009

In 2009, the Sheshan radio telescope was scheduled for twenty-two IVS experiments, although it failed to participate in four experiments due to an antenna mechanical problem. Some X band observations were subjected to pointing errors, leading to lower sensitivity.

In addition, the Sheshan telescope participated in thirty-five disk-based VLBI observations and twenty-six e-VLBI observations and formatter tests organized by the EVN, nineteen experiments for the Chinese Chang’E-1 lunar satellite, and some DBBC test experiments.

## 3. Development and Maintenance of Sheshan Telescope in 2009

One azimuth bearing was broken during an observation on September 11th. Then the broken bearing and three other old ones were replaced. The repair work and subsequent pointing tests took 40 days. As a result, the Sheshan station missed four IVS sessions: RD0908, R1399, RD0909, and APSG25.

The S/X receivers and the H-maser ran normally in 2009. The current FS version at the Sheshan station is 9.10.4. The VLBI terminal at the Sheshan station includes an ABBC, a Mark IV formatter, a Mark 5A recorder, and a new Mark 5B recorder. A problem in network transfer for Mark 5B was fixed; since then, recording with Mark 5B has run normally. The OS system of the Mark 5A computer has been upgraded to Debian 2.6.18.dfsg.1-23etch1, and the Mark 5A software version is 2007y222d02h.

The Sheshan radio telescope participated in 512 Mbps e-VLBI observations organized by the EVN. On January 15-16 2009 the Sheshan radio telescope participated in the 33-hour continuous “marathon” e-VLBI observation demonstrated live in the opening ceremony of the International Year of Astronomy 2009 in Paris. On April 3-5 2009, the Sheshan radio telescope participated in e-VLBI observations as a part of the “100 Hours of Astronomy”.

#### **4. The Personnel Changes of Sheshan VLBI Station**

Bo Xia will replace Tao An as the VLBI friend as of January 1st 2010.

#### **5. Prospect**

A new 6.7 GHz receiver with dual circular polarization will be available starting in spring 2010. It works at room temperature. The LO frequency is 5900 MHz, and the frequency coverage is from 6400 to 6825 MHz.

The Shanghai Astronomical Observatory is building a new 65 m radio telescope at a location about 4 km west of the current 25 m telescope site. It is scheduled to be completed in 2012. The highest frequency is 43 GHz, and the lowest one is 1.6 GHz.



# 15 Years of Geodetic Experiments at the Simeiz VLBI Station

*A.E. Volvach*

## Abstract

This report gives an overview about the geodetic VLBI activities during 15 years at the Simeiz station. We summarize briefly the status of 22-m radio telescope as an IVS Network Station.

## 1. General Information



Figure 1. Crimean Astrophysical Observatory.

The 22-m radiotelescope of the Crimean Astrophysical Observatory participated in the very first intercontinental very long baseline interferometric (VLBI) observations in September 1969 under astrophysical programs. The early narrow-band VLBI observations provided decimeter accuracy and were not useful for geodynamics applications. The telescope was upgraded in 1994: a Mark IIIA data acquisition terminal and a dual-frequency horn were loaned by NASA/GSFC,

dual band S/X receivers were supplied by the Institute of Applied Astronomy in Saint-Petersburg, Russia, and a CH-70 hydrogen maser was supplied by the Institute of Space Research in Moscow. Interferometric fringes were obtained in the first test carried out on June 20, 1994. This upgrade enabled the station to join international observing campaigns under both astrophysical and geodynamics programs.

The foundation pit of the telescope is nine meters deep, and it has three meters of crushed stones and then six meters of concrete. The height of the elevation axis above the foundation is 14.998 meters. The telescope is located 80 meters from the edge of the Black Sea. The parameters of the 22-meter radio telescope are presented in Table 1.

Table 1. The antenna parameters of the Simeiz station.

Diameter D	22 m
Surface tolerance (root mean square)	0.25 mm
Wavelength limit	2 mm
Feed System	Cassegrain system or primary focus
Focal length F	9.525 m
Focal ratio F/D	0.43
Effective focal length for Cassegrain system	134.5 m
Mounting	Azimuth-Elevation
Pointing accuracy	10 arcsec
Maximum rotation rate	1.5°/sec
Maximum tracking rate	150"/sec
Working range in Azimuth (0 to South)	-270° ± 270°
in Elevation	0° - 85°

The control system of the radio telescope provides the ability to point the antenna and to track the observed source in two modes: autonomous and automatic. All aspects of the radio telescope operation—antenna motion, radiometer readings, and data recording—are controlled from the special host computer in automatic mode. The 2 GHz and the 8 GHz receivers as well as the phase and the amplitude calibration units have been installed at the primary focus of the antenna.

## 2. Current Status and Activities

RT-22 was equipped with modern Mark 5A and Mark 5B+ VLBI recording systems and a new H-maser. That made it possible to continue astrophysical and fundamental geodetic VLBI observations.

The local geodetic ties between the VLBI, SLR, and GPS reference points of the station Simeiz-Katsively were analysed [1].

A number of relatively small regions of the Earth have been found where the annual periodicity of seismic activity is most prominent: the Balkans and Turkey, the isthmus between North America and South America, Alaska and the Aleutians, and some others. In both hemispheres, these regions are associated with subduction zones or intensely faulted segments of the continental crust [2].

Last year the Simeiz station regularly participated in various radio astronomy programs including VLBI and single-dish observations of quasars and planets.

Table 2. The current projects.

Very Long Baseline Interferometry	Astrophysics, geodesy, astrometry and radar projects with the international networks.
Monitoring of AGN	The regular monitoring at frequencies 22.2 and 36.8 GHz.
Molecular line observations at mm wavelength	Observations in molecular lines of maser sources, star forming regions and other objects have been intensively carried out since 1978 in the range from 1.6 GHz up to 115 GHz.

*Catalog of sources for flight program “Radioastron”.*

Observations of a sample of sources from the preliminary “Radioastron” catalog were obtained at 22.2 and 36.8 GHz with the RT-22 radio telescope of the Crimean Astrophysical Observatory [3]. We determined the distribution of the source spectral indices between these frequencies. The distributions of the spectral indices of the RT-22 sample are more meaningful than in the WMAP catalog (between 23 and 33 GHz) due to the input parameters of the source sample of the “Radioastron” catalog. We have plotted the  $\log(10dN/N_0) - \log S$  dependence down to flux levels of about 0.1 Jy using the survey data of near 22 GHz, where there is a reduction in the density of cosmological sources in relation to the stable Euclidean universe. The variability of individual sources in connection with flare activity was considered.

*Evolution of flux density and parsec-scale structure of compact extragalactic radio sources by monitoring at 4.8 – 36.8 GHz and imaging of geodetic VLBI observations.*

We present some results on the variability of radio sources which came from continuous monitoring observations made at 4.8 – 36.8 GHz at the Crimean Astrophysical Observatory (Ukraine) and the Michigan Radio Astronomy Observatory (USA), and from international geodetic VLBI observations carried out at 2 and 8 GHz. The combined analysis of integral flux density variations and milliarcsecond scale structures was performed for 32 sources. It was found that, for a number of sources, the flux density bursts at high frequencies are not accompanied by emerging new VLBI jet components, but for some objects the flux density changes occur quasi-simultaneously at different frequencies, and the bursts are accompanied by ejected new VLBI components [4].

*Search for radio flashes, caused by collisions of meteoroids with the Moon.*

An observing procedure for determining the nature of detected variations of lunar radio fluxes was developed [5]. The probability of detecting a KA SMART-1 impact radio flash was estimated. We estimated the upper limit of the intensity of the radio flashes produced by collisions of sporadic meteoroids with the Moon as  $10^{-7}$  JyJ<sup>-1</sup> at 3.6 cm.

*Binary systems of supermassive black holes in active galactic nuclei.*

On the basis of long-term monitoring of active galactic nuclei 3C454.3, 1633+382, and 3C120 observed at the Crimean Astrophysical Observatory from 1985–2008 at 22.2 and 36.8 GHz, we analyzed periodic components of flux variability. The long-period components of the sources’ variability (12–14 years) have been determined and are interpreted as the precessional motion of the central body in a double system. The short-period components of the variability (1.5–3 years) have been compared using models for the orbital periods for motion in the central supermassive black holes. The brightest representative active galactic nuclei, observed as non-stationary sources in a broad range of wave lengths, are binary systems of supermassive black holes, residing close to

the coalescence stage of stellar evolution.

The following parameters were determined for the supposed binary black hole system: the masses of the central object and its companion, the radius of the companion's orbit, and the coalescence time. The ratio of the masses of the double systems of all sources is less than 10, which indicates a strong gravitational effect of the central black hole on its companion. The velocity of the central body is a thousand km/sec. This requires an additional calculation to account for the rate of accretion to the central body [6].

The orbital radius of the companion has a close limit,  $(4 - 6)10^{16}$ cm, that indicates that the masses of the binary systems have a strong dependency on the orbit sizes and on the energy loss due to gravitational radiation. Shock waves created by the moving companion propagate within the highly dense ( $(10^9-10^{10}) \text{ cm}^{-3}$ ) ambient medium surrounding the central body, and some penetrate the central body's accretion disk. In addition, the companion has an elliptical orbit that plunges it into the accretion disk at the disk's pericenter. The fragmentary disruption of the accretion disk due to the moving companion can be accompanied by a powerful release of energy, which is transferred to the accretion disk's outflowing jets by the propagating shock waves.

*Subparsec structure of double supermassive black holes in active galactic nuclei.*

The analysis of long-term multifrequency monitoring of the radio flux of four active galactic nuclei (AGN) of BL Lac type: 3C 120, OJ 287, 1308+326, and BL Lac was carried out. The harmonic components of flux variability on the scale of one to ten years were determined. The observational data were obtained in the Radio Astronomy Laboratory SRI Crimean Astrophysical Observatory (Ukraine) and the Michigan Radio Astronomy Observatory (USA). Based on the observational data, the kinematic model of AGN using the values of the orbital and the precessional periods of binary systems of supermassive black holes (BSBH) were constructed. A narrow range of values (three to four thousand km/s) was obtained for the orbital velocities of the companions. In turn, the orbital radii of BSBH are also in a narrow range ( $(10^{17}-10^{18})$  cm), which supports the observation that the bright examples of AGN are close enough to double systems. The parameters of the medium in which the companions of double systems move, the rate losses of the orbital moments, and the coalescence times were estimated [7].

### 3. Future Plans

Our plan for the coming year is to put the VLBI Data Acquisition System DBBC into operation.

### References

- [1] Bolotina, O.V., et al. // Kinematics and Physics of Celestial Bodies. 2008. V.24. N.5, P.388.
- [2] Volvach A.E., Gorkavyi N.N., Dmytrotsa A.I., Levitskii L.S. // Bulletin of CrAO. 2008. V.104, P.145.
- [3] A.E. Volvach // Space Science and Technology. 2009. T.15. N.5. P.82-97.
- [4] A.E. Volvach, A.B. Pushkarev, L.N. Volvach, H.D. Aller, M.F. Aller // 2009. T. 15. N.4. P.33-57.
- [5] Volvach A.E., Berezhnoy A.A., Foing B., Erenfroyd P., Havroshkin O.B., Volvach L.N. // Kinematics and Physics of Celestial Bodies. 2009. Vol. 25, issue 4, pp. 194-197.
- [6] Volvach A. E. // Kinematics and Physics of Celestial Bodies. 2009. Vol.25, issue 5, pp. 385-401.
- [7] A.E. Volvach, L.N. Volvach, A.M. Kutkin, M.G. Larionov, M.F. Aller, and H.D. Aller // Astronomy Reports, 2010, Vol. 54, No. 1, pp. 28-37.

# Svetloe Radio Astronomical Observatory

*Sergey Smolentsev, Ismail Rahimov*

## Abstract

This report summarizes information on recent activities at the Svetloe Radio Astronomical Observatory (SvRAO) in 2009. The report provides also an overview of current geodetic VLBI activities and gives an outlook for the next year.

## 1. General Information

Svetloe Radio Astronomical Observatory (SvRAO) was founded by the Institute of Applied Astronomy (IAA) as the first station of the Russian VLBI network QUASAR.

The sponsoring organization of the project is the Russian Academy of Sciences (RAS). The Svetloe Radio Astronomical Observatory is situated near Svetloe village of Priozerski district of the Leningrad region (see Table 1). The geographic location of the observatory is shown on the IAA RAS Web site: <http://www.ipa.nw.ru/PAGE/rusipa.htm>. The basic instruments of the observatory are a 32-m radio telescope and technical systems for VLBI observations (see Fig. 1).



Figure 1. Svetloe observatory.

Table 1. Svetloe Observatory location and address.

Longitude	29°47'
Latitude	60°32'
Svetloe Observatory	
Leningrad region, Priozerski district	
188833 Russia	
rahimov@urania.rtf32s.nw.ru	

## 2. Technical and Scientific Information

Table 2. Technical parameters of the radio telescope.

Year of construction	2000
Mount	AZEL
Azimuth range	$\pm 270^\circ$ (from south)
Elevation range	from $-5^\circ$ to $95^\circ$
Maximum azimuth - velocity - tracking velocity - acceleration	1.5 $^\circ/s$ 1.5 $'/s$ 0.2 $^\circ/s^2$
Maximum elevation - velocity - tracking velocity - acceleration	0.8 $^\circ/s$ 1.0 $'/s$ 0.2 $^\circ/s^2$
Pointing accuracy	better than $10''$
Configuration	Cassegrain (with asymmetrical subreflector)
Main reflector diameter	32 m
Subreflector diameter	4 m
Focal length	11.4 m
Main reflector shape	quasi-paraboloid
Subreflector shape	quasi-hyperboloid
Surface tolerance of main reflector	$\pm 0.5$ mm
Frequency capability	1.4–22 GHz
Axis offset	$+7.5 \pm 0.5$ mm

## 3. Technical Staff

Ismail Rahimov — Observatory chief,  
 Tatiana Andreeva — main operator,  
 Andrey Mihailov — FS, pointing system controls.

## 4. Current Status and Activities

Svetloe observatory participates in IVS and Russian Domestic VLBI observations. During 2009 Svetloe station participated in 45 24-hour IVS-R4, IVS-R1, IVS-T2, EURO, and R&D sessions and in 21 IVS Intensive sessions (Table 3).

SvRAO observed nineteen daily sessions in the frame of domestic program Ru-E for VLBI determination of all Earth orientation parameters, and ten 4 1-hour Ru-U sessions for obtaining Universal Time. Since September the 2009 Ru-U sessions have been performed in e-VLBI mode.

Table 3. List of IVS sessions observed at SvRAO in 2009.

Month	IVS-Int	IVS-R1	IVS-R4	IVS-T2	R&D	EURO
January	2	1	3			
February	2	2	3		1	
March	2	2	2			
April	2	2	3	1		
May	2		3			
June	2	1	2			
July	2		4			1
August	2	3	3			
September	2	1				
October	2	1	4			
November	1	1	1			
December						
Total	21	14	28	1	1	1

After 12 November 2009 SvRAO stopped observing due to an antenna problem. The antenna will become operable after repair work.

## 5. Future Plans

Our plans for the coming year are the following:

- Participation in weekly domestic observational sessions for obtaining Earth orientation parameters and in weekly 1-hour e-VLBI sessions for UT1 determination.
- Continuation of geodetic control of the antenna parameters.
- GPS Javad receiver installation.
- Mounting LRS “Sazhen-TM” in 2010–2011.
- Participation in EVN observations.

# JARE Syowa Station 11-m Antenna, Antarctica

*Koichiro Doi, Kazuo Shibuya, Yuichi Aoyama*

## Abstract

The operation of the 11-m S/X-band antenna at Syowa Station (69.0°S, 39.6°E) by the Japanese Antarctic Research Expeditions (JAREs) started in February 1998 and continues until today (December 2009). A cumulative total of 88 quasi-regular geodetic VLBI experiments were observed by the end of 2009. Syowa Station will participate in six OHIG sessions in 2010.

The data from five OHIG sessions in 2009 were recorded on hard disks through the K5 terminal. They will be brought back from Syowa Station to Japan in April 2010. The data from the OHIG59 through OHIG61 sessions observed by JARE48 and JARE49 have been transferred to the Bonn Correlator directly by way of one of NICT's servers. Analysis results obtained from the data until the OHIG56 session indicate that the length of the Syowa-Hobart baseline is increasing with a rate of  $54.7 \pm 0.4$  mm/yr and that the length of the Syowa-HartRAO baseline is increasing with a rate of  $11.7 \pm 0.3$  mm/yr. The length of the Syowa-O'Higgins baseline is slightly increasing with a rate of  $1.7 \pm 0.9$  mm/yr.

## 1. Overview

Syowa Station has become one of the key observatories in the Southern Hemisphere's geodetic network, as reported in [1]. For VLBI, the Syowa antenna is registered as IERS Domes Number 66006S004 and as CDP Number 7342. The basic configuration of the Syowa VLBI front-end system has not changed from the description in [2].

A K5 recording system was introduced at Syowa Station in September 2004. Syowa's K4 recording terminal was fully replaced by K5 simultaneously with the termination of the SYW session at the end of 2004. Syowa has participated in the OHIG sessions in the austral summer season since 1999. Data transfer through an Intelsat satellite link from Syowa Station to NIPR became possible with the introduction of the K5 system, but huge VLBI data transfers are not realistic because of the low transfer speed.

## 2. Notes on System Maintenance

There is no significant problem in the "mechanical system". The hydrogen maser set (Anritsu RH401A; 1002C) was used for observations from 2004 to 2009. A backup hydrogen maser set (Anritsu RH401A; 1001C) is also operating normally. The tube in the Cs frequency comparator and local oscillator will have to be replaced with a new one in the near future.

## 3. Session Status

Table 1 summarizes the status of processing as of December 2009 for the sessions after 2004. The SYW sessions consisted of Syowa (Sy), Hobart (Ho), and HartRAO (Hh). The OHIG sessions involved Fortaleza (Ft), O'Higgins (Oh) and Kokee Park (Kk), Parkes (Pa) with TIGO Concepción (Tc), together with the three antennas of the SYW sessions. In 2005, Syowa joined the CRD sessions, but after 2006, Syowa participated only in OHIG sessions. Syowa participated in five OHIG sessions in 2009.

Until 2004, K4 tapes containing the OHIG sessions' data from Syowa Station were copied to



Mark IV tapes at GSI, and the Mark IV tapes were sent to the Mark IV Correlator for final correlation. Since the introduction of the K5 system, K5 hard disk data brought back from Syowa Station have been transferred by ftp to the MIT Haystack Observatory or the Bonn Correlator through a NICT server and converted to Mark 5 format data there.



Figure 1. Syowa VLBI staff for JARE-50 (February 2009 — January 2010).

#### 4. Staff of the JARE Syowa Station 11-m Antenna

- Kazuo Shibuya, Project coordinator at NIPR.
- Koichiro Doi, Yuichi Aoyama, Liaison officer at NIPR.
- Naoki Arai (from Electric Navigation Research Institute), Chief operator for JARE-48 (February 2007 — January 2008).
- Sachiko Nagashima (from MontBell Co., Ltd.) Operator for JARE-48.
- Hitoshi Sugawara (from NEC), Antenna engineer for JARE-48.
- Yuichi Aoyama (from National Institute of Polar Research), Chief operator for JARE-49 (February 2008 — January 2009).
- Hideaki Kumagai (from NEC), Antenna engineer for JARE-49.
- Yusuke Murakami (from University of Tokyo), Chief operator for JARE-50 (February 2009 — January 2010) (right in Figure 1).
- Yuji Yamaguchi (from NEC), Antenna engineer for JARE-50 (left in Figure 1).

Table 1. Status of SYW and OHIG experiments as of December 2009

Code	Date	Station	Hour	Correlation	Solution	Notes
OHIG29	2004/Feb/10	Ho, Hh, Ft, Oh, Tc	24 h	Yes	Yes	J45
SYW030	2004/Apr/07	Ho, Hh	24 h	Yes	Yes	
SYW031	2004/Aug/18	Ho, Hh	24 h	Yes	Yes	
OHIG32	2004/Oct/16	Ho, Hh, Ft, Oh, Kk, Tc	24 h	No	No	
OHIG33	2004/Nov/09	Ho, Ft, Oh, Kk, Tc	24 h	Yes	Yes	
OHIG34	2004/Nov/30	Ho, Hh, Ft, Oh, Kk, Tc	24 h	Yes	Yes	
OHIG35	2004/Dec/08	Ho, Hh, Ft, Oh, Kk, Tc	24 h	Yes	Yes	
SYW032	2004/Dec/13	Ho, Hh	24 h	Yes	Yes	
OHIG36	2005/Jan/26	Ho, Hh, Ft, Oh, Kk	24 h	Yes	Yes	
OHIG37	2005/Feb/02	Ho, Hh, Ft, Oh, Kk	24 h	Yes	Yes	J46
OHIG38	2005/Feb/15	Ho, Hh, Ft, Oh, Kk	24 h	Yes	Yes	
CRDS18	2005/Apr/11	Ho, Hh	24 h	Yes	Yes	
CRDS19	2005/May/10	45, Hh	24 h	Yes	Yes	
OHIG39	2005/Nov/08	Ho, Hh, Ft, Oh, Kk	24 h	Yes	Yes	
OHIG40	2005/Nov/09	Ho, Hh, Ft, Oh, Kk	24 h	Yes	Yes	
OHIG41	2005/Nov/16	Ho, Hh, Ft, Oh, Kk	24 h	Yes	Yes	
OHIG42	2006/Jan/31	Ho, Hh, Ft, Oh, Kk, Tc	24 h	Yes	Yes	
OHIG43	2006/Feb/08	Ho, Hh, Ft, Oh, Kk, Tc	24 h	Yes	Yes	J47
OHIG44	2006/Feb/14	Ho, Hh, Ft, Oh, Kk, Tc	24 h	Yes	Yes	
OHIG45	2006/Nov/07	Ho, Hh, Ft, Oh, Kk, Tc	24 h	Yes	Yes	
OHIG46	2006/Nov/14	Ho, Hh, Oh, Kk, Tc	24 h	Yes	Yes	
OHIG47	2006/Nov/29	Ho, Hh, Ft, Oh, Kk, Tc	24 h	Yes	Yes	
OHIG49	2007/Feb/13	Ho, Hh, Ft, Oh, Kk, Tc	24 h	Yes	Yes	J48
OHIG51	2007/Nov/06	Ho, Ft, Oh, Kk, Tc	24 h	Yes	Yes	
OHIG52	2007/Nov/07	Ho, Ft, Oh, Kk, Tc	24 h	Yes	Yes	
OHIG53	2007/Nov/13	Ho, Hh, Ft, Oh, Kk, Pa, Tc	24 h	Yes	Yes	
OHIG54	2007/Nov/14	Ho, Hh, Ft, Oh, Kk, Pa, Tc	24 h	Yes	Yes	
OHIG55	2008/Feb/06	Hh, Oh, Kk, Tc	24 h	Yes	Yes	J49
OHIG56	2008/Feb/12	Hh, Oh, Kk, Tc	24 h	Yes	Yes	
OHIG57	2008/Feb/13	Hh, Oh, Kk, Tc	24 h	Not yet	Not yet	
OHIG59	2008/Nov/12	Ho, Ft, Oh, Kk, Tc	24 h	Not yet	Not yet	
OHIG60	2008/Nov/18	Ho, Ft, Oh, Kk, Pa, Tc, Ts	24 h	Not yet	Not yet	
OHIG61	2008/Nov/19	Ho, Ft, Oh, Kk, Tc	24 h	Not yet	Not yet	
OHIG62	2009/Feb/04	Ft, Ho, Kk, Oh, Tc	24 h	Not yet	Not yet	J50
OHIG63	2009/Feb/10	Ft, Ho, Kk, Oh, Tc	24 h	Not yet	Not yet	
OHIG64	2009/Feb/11	Ft, Ho, Kk, Oh, Tc	24 h	Not yet	Not yet	
OHIG65	2009/Nov/10	Ho, Kk, Oh, Tc	24 h	Not yet	Not yet	
OHIG66	2009/Nov/11	Ho, Kk, Oh, Tc	24 h	Not yet	Not yet	

45: DSS45, Ts: Tsukuba32

J45: JARE-45 op K. Doi eng K. Fukuhara

J46: JARE-46 op K. Egawa eng I. Okabayashi

J47: JARE-47 op T. Sawagaki eng H. Ishii

J48: JARE-48 op N. Arai eng H. Sugawara

J49: JARE-49 op Y. Aoyama eng H. Kumagai

J50: JARE-50 op Y. Murakami eng Y. Yamaguchi

## 5. Analysis Results

As of the end of December 2009, 63 sessions from May 1999 through February 2008 have been analyzed with the software CALC/SOLVE developed by NASA/GSFC. The data of nine OHIG sessions from OHIG57 through OHIG66 will be analyzed soon.

The length of the Syowa-Hobart baseline is increasing with a rate of  $54.7 \pm 0.4$  mm/yr. The Syowa-HartRAO baseline shows a slight increase with a rate of  $11.7 \pm 0.3$  mm/yr. These results agree approximately with those of GPS. The Syowa-O'Higgins baseline also shows a slight increase, although the rate is only  $1.7 \pm 0.9$  mm/yr. Detailed results from the data until the end of 2003 as well as comparisons with the results from other space geodetic techniques are reported in [3].

## References

- [1] Shibuya, K., Doi, K., and Aoki, S. (2003): Ten years' progress of Syowa Station, Antarctica, as a global geodesy network site. *Polar Geoscience*, 16, 29-52.
- [2] Shibuya, K., Doi, K., and Aoki, S. (2002): JARE Syowa Station 11-m Antenna, Antarctica, in *International VLBI Service for Geodesy and Astrometry 2002 Annual Report*, 149-152, NASA/TP-2003-211619, ed. by N. R. Vandenberg and K. D. Baver.
- [3] Fukuzaki, Y., Shibuya, K., Doi, K., Ozawa, T., Nothnagel, A., Jike, T., Iwano, S., Jauncey, D.L., Nicolson, G.D., and McCulloch, P.M. (2005): Results of the VLBI experiments conducted with Syowa Station, Antarctica. *J. Geod.*, 79, 379-388.

## Geodetic Observatory TIGO in Concepción

*Sergio Sobarzo, Eric Oñate, Cristian Herrera, Pedro Zaror, Cristian Duguet, Miguel Soto, Hayo Hase, Tatjana Blum*

### Abstract

During 2009, the eighth year of operation in Chile, TIGO participated successfully in 116 VLBI observations. Activities of the VLBI group at TIGO during 2009 and an outlook for 2010 are given.

### 1. General Information

The operation of TIGO is based on a bilateral agreement between the Republic of Chile and the Federal Republic of Germany, in which the following institutions participate:

- Universidad de Concepción (Chile)
- Instituto Geográfico Militar (Chile)
- Bundesamt für Kartographie und Geodäsie (Germany)

TIGO is located in the upper terrain of the Universidad de Concepción, 2.5 kilometers away from the University's campus (long. 73.025 degrees West, lat. 36.843 degrees South), in Concepción city, the second largest city of Chile, at a distance of 500 km from its capital, Santiago de Chile.

### 2. Component Description

The IVS network station TIGOCONC constitutes the VLBI part of the Geodetic Observatory TIGO, which was designed to be a fundamental station for geodesy. Hence, the VLBI radiotelescope is co-located to an SLR telescope (ILRS site), a GPS/Glonass permanent receiver (IGS site) and other instruments such as a seismometer, a superconducting gravimeter, and an absolute gravity meter.

The atomic clock ensemble of TIGO consists of three hydrogen masers, three cesium clocks and four GPS time receivers realizing the Chilean contribution to the Universal Time scale (Circular T, BIPM).

The technical parameters of the TIGO radiotelescope as published in [1] have not been changed.

### 3. Staff

The VLBI staff changed in two positions. Cristobal Jara left TIGO at the beginning of the year, as did Jenny Neumann, who was replaced by Tatjana Blum in the beginning of 2010. The 2009 TIGO VLBI group consisted of the persons listed in Table 1.

### 4. Current Status and Activities

During 2009 TIGO was scheduled to participate in 117 IVS experiments (see Table 2), and four 24-hour experiments in the frame of the TANAMI program [2]. TIGO also participated in the IYA2009 Very Large Astrometry session.

On November 18th, TIGO took part in the IVS contribution to the International Year of Astronomy (IYA) 2009 realizing together with 35 other radiotelescopes, the largest VLBI experiment ever.

The participation of TIGO in collaboration with O'Higgins in the TANAMI program significantly extended the Australian Long Baseline Array. TANAMI scientists achieved the most accurate images of Centaurus-A so far.

Table 1. TIGO-VLBI support staff in 2009.

Staff	Function	Email
Hayo Hase	Head	hayo.hase@tigo.cl
Sergio Sobarzo	Chief Engineer	sergio.sobarzo@tigo.cl
Eric Oñate	Electronic Engineer	eric.onate@tigo.cl
Cristian Herrera	Informatic Engineer	cristian.herrera@tigo.cl
Pedro Zaror	Mechanical Engineer	perdo.zaror@tigo.cl
Cristian Duguet	Electronic Engineer	cristian.duguet@tigo.cl
Miguel Soto	Electronic Engineer	miguel.soto@tigo.cl
Tatjana Blum	Secretary (since 2010)	tatjana.blum@tigo.cl
any VLBI-operator	on duty	vlbi@tigo.cl
all VLBI-operators		vlbistaff@tigo.cl



Figure 1. Current VLBI Staff (Hase, Soto, Duguet, Herrera, Oñate, and Sobarzo). Zaror was absent.

Table 2. TIGO's IVS observation statistics for 2009.

Name	# of Exp.	OK	Failed
R1xxx	46	45	1
R4xxx	47	47	0
R&D	8	8	0
OHIGxx	5	5	0
T20xx	7	7	0
Tanami	3	3	0
IYA	1	1	1
Total IVS	117	116	1

#### 4.1. Receiver Control and Monitoring Upgrade

Early this year a new self-developed receiver control and monitoring system was installed. Many alternatives were evaluated as replacement of the old 386 based system. The design objectives were resistance to vibrations, fast communication with the FS—preferably over Ethernet—modularity, and easy maintenance. Since the TIGO ACU system is partly based on Beckhoff components, which have proven their reliability throughout the years, the receiver monitoring system was also based on Beckhoff components.

The core of the system is the Beckhoff BK9000 Ethernet TCP/IP Bus Coupler which communicates with the FS using the ModBus protocol. Attached to this device are four analog input modules providing a total of 32 inputs and one relay module with two outputs.

The communication was realized by using media converters from twisted pair to coaxial in order to utilize an unused spare of the existing antenna cabling. Ethernet type communication allows higher data rates and a better reliability than the serial type used before.

A picture of the modules in the receiver is shown in Figure 2 (left). Monitoring of the receiver's parameters was added to the FS by a dedicated RX control window as is shown in Figure 2 (right).

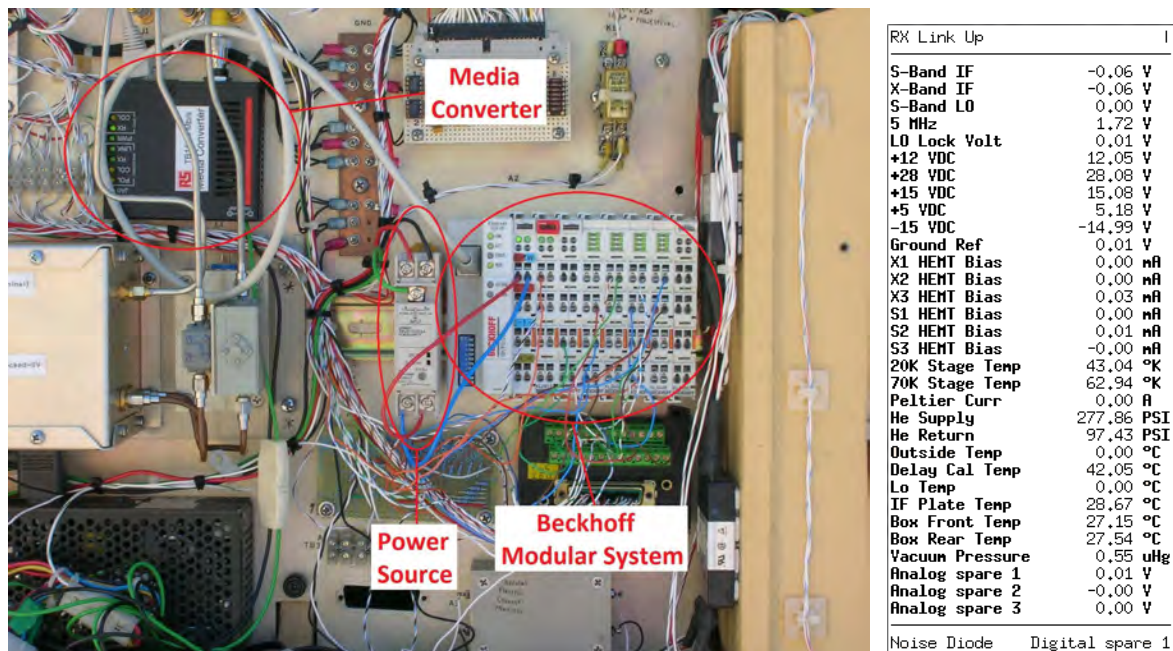

Figure 2. Left: New receiver control and monitoring installed in the receiver of the radio telescope. Right: New receiver monitoring windows added to the FS desktop.

#### 4.2. Local Oscillator Upgrade

In late 2008, TIGO began having troubles with its local oscillator at the front-end. In February 2009, the TIGO VLBI team replaced the old 2020 MHz local oscillator model P-8333 of CTI Inc. in the telescope with a Phase Locked Dielectric Resonator Oscillator (PLDRO). This LO, designed by Gerhard Kronschnabl at Wettzell, consists of the elements listed in Table 3.

This new oscillator is much more stable and reliable, and it is able to work between  $-20^{\circ}\text{C}$  and

45°C, with a power output higher than 13dB. After its installation, TIGO's operations did not suffer from LO problems anymore.



Figure 3. Replacement of the old Local Oscillator (upper circle) by the new LO (lower circle).

Table 3. Components of the new TIGO PLDRO.

Amount	Component
1	NXPLOS-0202-02782
1	NXPLOS-0808-02782
1	PLXO

## 5. Future Plans

The VLBI activities in 2010 will be focused on:

- execution of the IVS observation program for 2010
- continuation of developments, such as
  - investigations related to e-VLBI and
  - a new auxiliary power system for the cryogenic compressor and receiver
- repetition of the local survey

## References

- [1] Vandenberg, N.R.: International VLBI Service for Geodesy and Astrometry 1999 Annual Report, NASA/TP-1999-209243, 1999.
- [2] M. Kadler, R. Ojha, S. Tingay and J. Lovell, *The TANAMI Program: Southern-Hemisphere VLBI Monitoring of Relativistic Jets in Active Galaxies*, American Astronomical Society, AAS Meeting #211, #04.13; Bulletin of the American Astronomical Society, Vol. 39, p. 732.

# Tsukuba 32-m VLBI Station

*Shinobu Kurihara, Shigeru Matsuzaka*

## Abstract

The Tsukuba 32-m VLBI station is operated by the Geographical Survey Institute (GSI) VLBI group. This report summarizes the current status and the future plans of the Tsukuba 32-m VLBI station.

In 2009 we participated in a total of 209 domestic and international VLBI sessions in accordance with the IVS Master Schedule. The IYA2009 special session in November was the noteworthy event. In addition, several ultra-rapid dUT1 experiments were conducted this year.

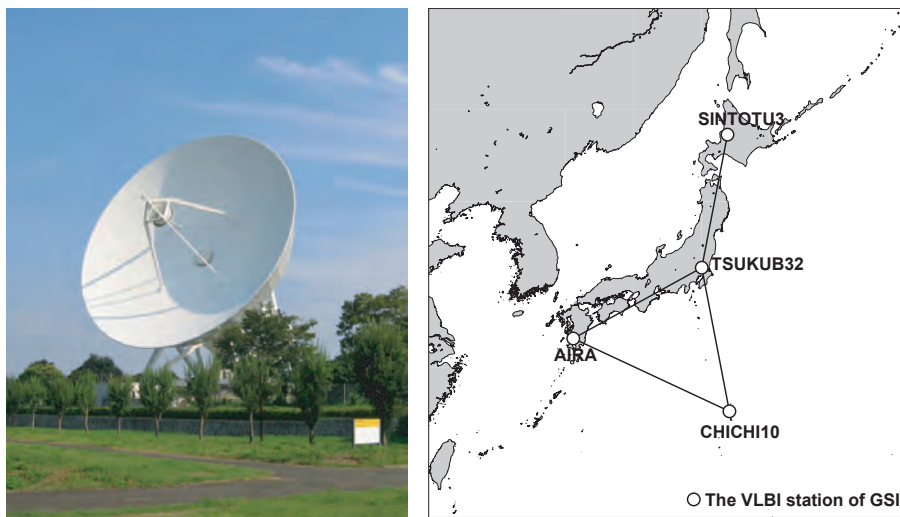

Figure 1. Tsukuba 32-m VLBI station and GARNET (GSI VLBI network).

## 1. General Information

The Tsukuba 32-m VLBI station (TSUKUB32) is located at GSI in Tsukuba Science City which is about 50 km to the northeast of the capital Tokyo.

GSI has three regional stations besides TSUKUB32: SINTOTU3, CHICHI10, and AIRA. All four stations form our domestic VLBI network named GARNET (*G*SI *A*dvanced *R*adio telescope *NET*work). We have performed our domestic VLBI observations using GARNET. A series of the observations is named JADE (*J*Apanese *D*ynamic *E*arth observation by VLBI). The main purposes of the JADE series are to define the reference frame of Japan and to monitor the plate motions for the advanced study of crustal deformations. The GARNET stations, centered on TSUKUB32, are located to cover the Japanese mainland. The GARNET stations other than TSUKUB32 have joined some of the international VLBI sessions since 2008.

## 2. Component Description

The antenna specifications of the Tsukuba 32-m antenna are summarized in Table 1.



Table 1. Tsukuba 32-m antenna specifications

Owner and operating agency	Geographical Survey Institute
Year of construction	1998
Radio telescope system	Az-EI
Receiving feed	Cassegrain
Diameter of main reflector	32 m
Azimuth range	10 – 710°
Azimuth velocity	3°/sec
Elevation range	5 – 88°
Elevation velocity	3°/sec
Tsys (X/S)	50 K / 75 K
SEFD (X/S)	320 Jy / 360 Jy
RF range (X1)	7780 – 8280 MHz
RF range (X2)	8180 – 8680 MHz
RF range (X3)	8580 – 8980 MHz
RF range (S with BPF)	2215 – 2369 MHz
Recording terminal	K5/VSSP32

In 2009, no new equipment was installed at the station. Since the Field System PCs installed in 2002 had a problem with their motherboards, repair work was performed using parts of a backup PC. And in case of future trouble with the Field System PC, we set up a new backup PC for the Field System.

Since last year, the Tsukuba e-VLBI network joined SINET3 (The *Science Information NET*work 3). A reduction of the rate of data transfer occasionally occurred, but it was improved by updating ROM in the network switch. Now the network maintains a stable speed of about 600 Mbps. All VLBI data obtained at TSUKUB32, SINTOTU3, CHICHI10, and AIRA is transferred to an overseas correlator via SINET3.

### 3. Staff

Table 2 lists the regular operating staff of GSI's VLBI observation group.

Kozin Wada (the former Deputy head) moved to another organization. Yoshihiro Fukuzaki succeeded to the Deputy head position. Yuji Miura newly joined the VLBI section as a technical staff member. Kazuhiro Takashima was elected as an IVS Directing Board at-large member. Kensuke Kokado began staying at the Haystack Observatory in the US as a visiting researcher for one year, starting on January 7, 2009. Routine operations were mainly performed under contract with Advanced Engineering Service Co., Ltd. (AES).

Table 2. Staff list of the GSI VLBI group

Name	Position
Shigeru MATSUZAKA	Head of Space Geodesy Division
Yoshihiro FUKUZAKI	Deputy head of Space Geodesy Division
Shinobu KURIHARA	Responsible official
Kensuke KOKADO	Visiting researcher at Haystack
Yuji MIURA	Technical staff
Daisuke TANIMOTO	Technical operator (Observation)
Yasuko MUKAI	Technical operator (Observation and Correlation)
Toshio NAKAJIMA	System engineer (Network)
Kazuhiro TAKASHIMA	Senior researcher, IVS DB at-large member

## 4. Current Status and Activities

### 4.1. Geodetic VLBI Observations

The regular sessions in the IVS 2009 Master Schedule are shown in Table 3. TSUKUB32 participated in 58 domestic and international 24-hr VLBI sessions and 151 Intensive 1-hr sessions this year. SINTOTU3, CHICHI10, and AIRA also participated in some international sessions.

Table 3. The number of regular sessions in 2009

Sessions	TSUKUB32	SINTOTU3	CHICHI10	AIRA
IVS-R1	35	–	–	–
IVS-T2	7	–	7	7
APSG	2	2	2	2
VLBA	3	–	–	–
IVS-R&D	3	–	–	–
IYA2009	1	1	1	1
JADE	7	5	7	7
IVS-INT2	102	–	–	–
IVS-INT3	49	–	–	–
Total	209	8	17	17

### 4.2. Special Astrometric Session IYA2009

In November, TSUKUB32, SINTOTU3, CHICHI10, and AIRA participated in the IYA2009 special session commemorating the International Year of Astronomy 2009. Since a major goal of the session was outreach, GSI issued a press release, and the article appeared in a newspaper. In addition the real-time streaming video of TSUKUB32 was distributed to the world via the Internet, and images were updated every minute and posted from SINTOTU3, CHICHI10, and AIRA.

### 4.3. Ultra-Rapid dUT1 Experiments

Following last year's results, we continued the Ultra-rapid dUT1 experiments. This experimental effort is a joint project of Japan (GSI & NICT) and Fennoscandia (Onsala & Metsähovi). As a new effort, we tried to transfer the regular IVS 24-hr data from Onsala to the Tsukuba correlator and to carry out automatic data conversion, correlation, and data analysis. The experiment was conducted in four IVS 24-hr sessions: R1385 (June 29), RD0907 (July 8), R1409 (December 14), and RD0910 (December 16). Since the recording rate of these sessions was 256 Mbit/sec, nothing went wrong with the data transfer. A set of 35 observations was analyzed in near real-time and produced a dUT1 estimate. We were able to obtain the dUT1 result within about 20 minutes after the end of the last scan in a set of 35 observations. As a result, the contiguous dUT1 values were obtained every few minutes.

### 4.4. Developing a Compact VLBI System (MARBLE)

GSI and NICT (National Institute of Information and Communications Technology) are developing a compact VLBI system with a 1.5-m diameter aperture dish (MARBLE: Multiple Antenna Radio-interferometry of Baseline Length Evaluation) in order to provide reference baseline lengths for GPS and EDM calibration. In 2009, the first MARBLE system was installed in Kashima, followed by the second MARBLE system in Tsukuba by NICT. The first geodetic experimental observation was carried out in December between two MARBLEs and two large antennas (TSUKUB32 & KASHIM34). Now the data is being correlated.

## 5. Future Plans

In March 2010, a new hydrogen maser "Anritsu SA0D05A" and a high-speed digital sampler "ADS3000 plus" will be installed in the Tsukuba 32-m observation room.

## 6. Other Topics

The English name of the Geographical Survey Institute will change to the Geospatial Information Authority of Japan starting in April 2010. The abbreviated name (GSI) will remain as before. Additionally, the official organization logo was determined (see Figure 2).



Figure 2. Official organization logo of GSI

# New Zealand 12-m VLBI Station

*Sergei Gulyaev, Tim Natusch*

## Abstract

This report provides geographical and technical details of a new 12-m geodetic VLBI antenna operated by the Institute for Radio Astronomy and Space Research at Auckland University of Technology. Details of the VLBI system installed in the station are outlined. A co-located GNSS station and specialized surveying equipment are also described.

## 1. Introduction

The IVS VLBI2010 Progress Report [1] outlines a number of strategies to improve the long-term accuracy of geodetic VLBI with an eye to achieving 1 mm long-term accuracy on baselines. Among these strategies are: “to increase the number of antennas and improve their geographic distribution” and “to increase the number of observations per unit of time”. These IVS strategies can best be addressed through construction of new small ( $\sim 12$  m), fast-slewing automated antennas in areas that are under-represented (Southern Hemisphere) or lack geodetic VLBI stations (e.g. New Zealand).

Developing this approach, AUT University has invested US\$1m in a geodetic VLBI system, consisting of a fast-slewing automated 12-m antenna, hydrogen maser clock, digital receiving and digital backend systems, and a 1 Gbps network connectivity.

The 12-m antenna installed in August–September 2008 and officially launched on 8 October 2008 (Figure 1) is scheduled to start participating in regular IVS VLBI sessions from the middle of 2010.



Figure 1. New Zealand 12-m VLBI antenna

## 2. Geographical Information

The New Zealand VLBI Station is located at Satellite Station Valley some 5 km south of the township of Warkworth, which is about 60 km north of the city of Auckland (Figure 2).

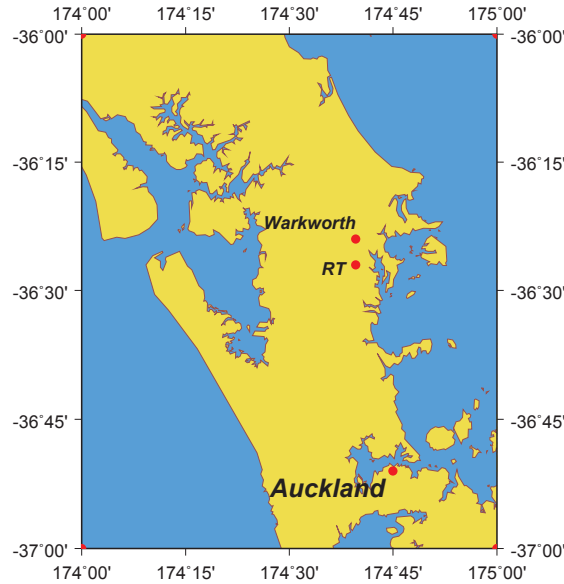

Figure 2. Map of New Zealand’s North Island. Location of the VLBI station and Warkworth are indicated. (Projection: Mercator)

The valley is owned by Telecom New Zealand with several satellite dishes installed (of which a 30-m is the biggest one) and operated to provide communication between New Zealand and Pacific Islands (Fiji, Cook Islands, Samoa) and Antarctica (Scott Base). The dishes are directed towards geostationary satellites to the north of the site and operate in C-band (4 and 6 GHz). The location is reasonably radio quiet in both S and X bands, and it is protected by local by-law from potential RFI sources.

The location of the antenna’s rotational axes intersection was surveyed to a decimeter accuracy with the use of the real-time kinematic GPS (see [2]).

The approximate location of the antenna axes intersection is

Latitude:  $36^{\circ}26'05.338''$  S

Longitude:  $174^{\circ}39'47.699''$  E

X = -5115327.28 m

Y = 477844.04 m

Z = -3767196.04 m

### 3. Technical Information

The 12-m Radio Telescope (RT) was manufactured by Patriot Antennas Inc. in Albion, Michigan, USA.

The list below provides technical specifications for the high-frequency RTNF antenna:

- Diameter: 12.1 m
- Surface Accuracy 0.36 mm (0.014 inches) rms.

- Frequency range: 1.6 - 32 GHz.
- Dual shaped Cassegrain,  $F/D = 0.375$  (primary surface)
- Directive efficiency: 85%
- Pointing Accuracy: 0.005 degree
- Operational temperature range: -15 to +55 deg C
- Specs apply in winds of 30 mph (50 km/h)
- 100 mph (160 km/h) survival in stow
- + 4.5 to 88 deg elevation travel
- +/- 270 degree azimuth travel
- Slew and scan rates
  - Up to 5 deg/s in Azimuth
  - Up to 1 deg/s in Elevation

Installation of the 12-m radio telescope was finished in October 2008 with the first light in August 2009. The radio telescope is equipped with the coaxial dual band (S and X) dual polarization (circular left/right) feed horn, which was specifically developed by Patriot Antennas. Four MITEQ's high-gain low-noise amplifiers (LNAs) are installed for both S and X bands and both polarizations. Symmetricom Active Hydrogen Maser MHM-2010 (75001-114) has three outputs @ 5 MHz, one output @ 10 MHz, one output @ 100 MHz, two outputs @ 1 pps (pulse per second), and a 1 pps sync. A separate distribution amplifier unit allows up to 15 outputs of the 10 MHz signal to be obtained. A digital base band converter (DBBC) developed at the Italian Institute of Radio Astronomy is expected to be installed in May 2010. The AUT VLBI receiving system uses the Mark 5B+ data recorder developed at MIT Haystack Observatory.

Both S and X receivers have been installed, and preliminary figures for SEFD are around 4000 Jy, a figure that is higher than expected. Investigations in collaboration with the manufacturer are underway, and several areas in which improvements can be made have been identified.

#### 4. Co-located Facilities

New Zealand's traditional role in contributing to global reference frame determination is through its GNSS PositionNZ network operated by Land Information New Zealand in a partnership with the Geological and Nuclear Sciences Research Institute (GNS Science). The PositionNZ network consists of 33 GNSS continuously operating reference stations (CORS) in mainland New Zealand, 1 on the Chatham Island (400 km east of Christchurch) and 3 in Antarctica [5]. Data from several of these sites are forwarded to the International GNSS Service (IGS) where they are incorporated into solutions used to determine GNSS satellite orbit and global reference frame determinations.

In November 2008 a new PositionNZ station (WARK) was built at the AUT radio telescope site, and an accurate tie has been established between the radio telescope antenna and the GNSS

antenna. With this purpose, four geodetic monuments were built in the vicinity of the antenna (15-20 m from its pedestal).

## 5. Network Connectivity

With wide spread development of e-VLBI, the issue of broadband network connectivity becomes essential for both existing and emerging radio astronomical facilities.

Internationally, New Zealand's major broadband supplier is Southern Cross Cables Ltd—a commercial organization, which owns and operates the cable connecting New Zealand with Australia in the West and with the US in the South-North direction. This is a multi-wavelength cable with the capacity of 1 Tbps.

Locally, the regional advanced network operating in New Zealand is KAREN (Kiwi Advanced Research and Education Network), which provides a 10 Gbps connectivity between New Zealand's educational and research institutions. KAREN is planning to establish a GigaPoP in Warkworth near the location of the 12-m radio telescope.

## 6. Education

The radio telescope is operated by the Institute for Radio Astronomy and Space Research (IRASR). Being a research tool for astronomy and geodesy, the antenna is also used in a new educational program in astronomy started in 2009 at AUT's School of Computing and Mathematical Sciences—an Astronomy Major in the framework of the Bachelor of Mathematical Sciences degree. It is envisaged that both undergraduate and postgraduate students will use the radio telescope in their research projects and as a teaching resource in the courses taught at AUT such as Astrophysics, Radio Astronomy, Practical Astrophysics, Space Geodesy and others.

## References

- [1] Petrachenko, B. et al., Design Aspects of the VLBI2010 System. Progress Report of the IVS VLBI2010 Committee. NASA/TM-2009-214180, June 2009.
- [2] Gulyaev, S. and Natusch, T. Characterisation and calibration of the 12-m antenna in Warkworth, New Zealand. Submitted to the International VLBI Service for Geodesy and Astrometry 2010 General Meeting Proceedings.
- [3] Gulyaev, S., Natusch, T., Tingay, S. and Deller A. Development of New Zealand radio astronomy and Trans-Tasman long-baseline array. *Southern Stars*, Vol. 44, No. 4, pp. 12–18, 2005.
- [4] Gulyaev, S., Natusch, T., Tingay, S., Deller, A., West, C., Ellingsen, S., McCulloch, P., Reid, B., Baynes, E. and Tzioumis, T. First steps towards radio astronomy in New Zealand. *ATNF News*, Issue 58, 2006.
- [5] [www.linz.govt.nz/positioNZ](http://www.linz.govt.nz/positioNZ)

# Westford Antenna

*Mike Poirier*

## Abstract

Technical information is provided about the antenna and VLBI equipment at the Westford site of the Haystack Observatory and about changes to the systems since the IVS 2008 Annual Report.

## 1. Westford Antenna at Haystack Observatory

Since 1981 the Westford antenna has been one of the primary geodetic VLBI sites in the world. Located  $\sim 70$  km northwest of Boston, Massachusetts, the antenna is part of the MIT Haystack Observatory complex.



Figure 1. The radome of the Westford antenna.

Table 1. Location and addresses of the Westford antenna.

Longitude	71.49° W
Latitude	42.61° N
Height above m.s.l.	116 m
MIT Haystack Observatory Off Route 40 Westford, MA 01886-1299 U.S.A. <a href="http://www.haystack.mit.edu">http://www.haystack.mit.edu</a>	

The Westford antenna was constructed in 1961 as part of the Lincoln Laboratory Project Westford that demonstrated the feasibility of long-distance communication by bouncing radio signals off a spacecraft-deployed belt of copper dipoles at an altitude of 3600 km. In 1981 the antenna was converted to geodetic use as one of the first two VLBI stations in the National Geodetic Survey Project POLARIS. Westford has continued to perform geodetic VLBI observations on a regular



basis since 1981. Westford has also served as a test bed in the development of new equipment and techniques now employed in geodetic VLBI worldwide. Funding for geodetic VLBI at Westford is provided by the NASA Space Geodesy Program.

## 2. Technical Parameters of the Westford Antenna and Equipment

The technical parameters of the Westford antenna, which is shown in Figure 2, are summarized in Table 2.

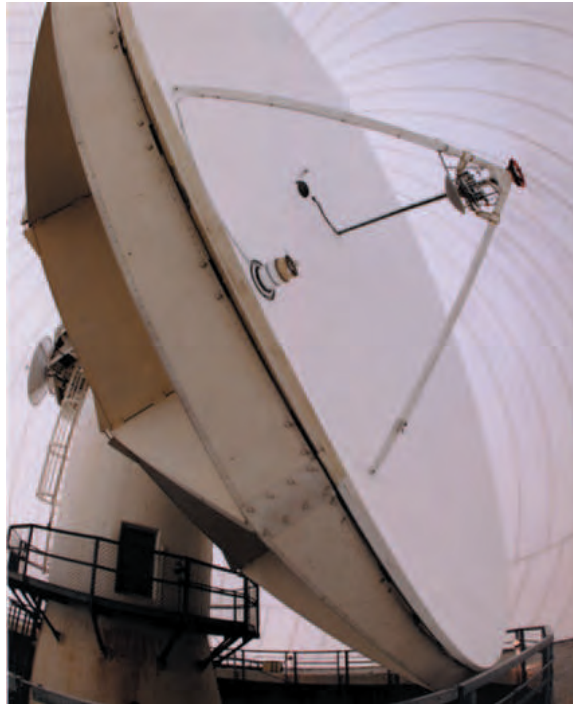

Figure 2. Wide-angle view of the Westford antenna inside the radome. The VLBI S/X receiver is located at the prime focus. The subreflector in front of the receiver is installed when observing with the TAL receiver (see Section 4), which is located at the Cassegrain focus.

The antenna is enclosed in a 28-meter diameter air-inflated radome made of 1.2-mm thick, Teflon-coated fiberglass—see Figure 1. When the radome is wet, system temperatures increase by 10–20 K at X-band and by a smaller amount at S-band. The major components of the VLBI data acquisition system are a Mark IV electronics rack, a Mark 5B recording system, and a Pentium-class PC running PC Field System version 9.10.2. The primary frequency and time standard is the NR-4 hydrogen maser. A CNS Clock GPS receiver system provides independent timing information and comparisons between GPS and the maser. Westford also hosts the WES2 GPS site of the IGS network. A Dorne-Margolin choking antenna is located on top of a tower ~60 meters from the VLBI antenna, and a LEICA GRX1200 Reference Station receiver acquires the GPS data.

Table 2. Technical parameters of the Westford antenna for geodetic VLBI.

<i>Parameter</i>	<i>Westford</i>	
primary reflector shape	symmetric paraboloid	
primary reflector diameter	18.3 meters	
primary reflector material	aluminum honeycomb	
S/X feed location	primary focus	
focal length	5.5 meters	
antenna mount	elevation over azimuth	
antenna drives	electric (DC) motors	
azimuth range	90° – 470°	
elevation range	4° – 87°	
azimuth slew speed	3° s <sup>-1</sup>	
elevation slew speed	2° s <sup>-1</sup>	
	<i>X-band system</i>	<i>S-band system</i>
frequency range	8180-8980 MHz	2210-2450 MHz
$T_{sys}$ at zenith	50–55 K	70–75 K
aperture efficiency	0.40	0.55
SEFD at zenith	1400 Jy	1400 Jy

### 3. Westford Staff

The personnel associated with the VLBI program at Westford and their primary responsibilities are:

Chris Beaudoin	broadband development
Joe Carter	antenna controls
Brian Corey	VLBI technical support
Kevin Dudevoir	pointing system software
Dave Fields	technician, observer
Glenn Millson	observer
Arthur Niell	principal investigator
Michael Poirier	site manager
Alan Whitney	site director

### 4. Status of the Westford Antenna

From January 1, 2009 through December 31, 2009, Westford participated in 40 standard 24-hour geodetic sessions. Westford regularly participated in the IVS-R1, IVS-R&D, and the RD-VLBA sessions along with fringe tests, e-VLBI experiments, and extensive VLBI2010 broadband development testing.

Use of the Westford antenna is shared with the Terrestrial Air Link (TAL) Program operated by the MIT Lincoln Laboratory. In this project Westford serves as the receiving end on a 42-km long terrestrial air link designed to study atmospheric effects on the propagation of wideband communications signals at 20 GHz.

## 5. e-VLBI Development at Westford

Westford continued to play a key role in e-VLBI by participating in the kickoff of the IYA e-VLBI 24-hour demonstration in January 2009. The outlook for 2010 is that e-VLBI development will increase substantially with the expected technology advances and availability of the RDBE and the Mark 5C, specifically by using the new 10 Gbps Ethernet interface and by implementing the new VLBI Data Interchange Format (VDIF) standard. These efforts are important for the VLBI2010 broadband development program.

## 6. VLBI2010

In 2009, Westford played a critical role in the VLBI2010 effort as one of the two stations (GGAO being the other) composing the only functional broadband geodetic VLBI baseline. This year in broadband development saw the detection of fringes from 3.4 - 11.5 GHz, thereby demonstrating the wideband capability of the system. Later in the year, after mitigating various RFI sources, a leakage problem with the Westford phase calibration generator was discovered. This leakage was a major factor limiting the precision to which phase delay ambiguities could be resolved. This discovery prompted the development of a new phase calibration generator enclosure being designed by Honeywell-TSI specifically for broadband operation; the new generator is expected to be installed at both sites in early 2010. Other enhancements to the broadband hardware expected in 2010 include the installation of the RDBE and Mark 5C which will enable data recording at 4 Gbps.

## 7. Outlook

Westford is expected to participate in 61 24-hour geodetic sessions in 2010. We also plan to have the flexibility to support the occasional fringe test and e-VLBI experiments while continuing the VLBI2010 broadband development testing.

# Geodetic Observatory Wettzell - 20 m Radiotelescope

*Alexander Neidhardt, Gerhard Kronschnabl, Raimund Schatz*

## Abstract

In the year 2009 the 20-m radiotelescope at the Geodetic Observatory Wettzell, Germany contributed again very successfully and strongly to the IVS observing program. Technical changes, developments, improvements, and upgrades have been done to increase the reliability of the entire VLBI observing system.

## 1. General Information

The 20-m radiotelescope in Wettzell (RTW) is an essential component of the Geodetic Observatory Wettzell (GOW) and is jointly operated by Bundesamt für Kartographie und Geodäsie (BKG) and Forschungseinrichtung Satellitengeodäsie (FESG) of the Technical University Munich. In addition to the RTW, the following geodetic space techniques and local systems are co-located at the GOW:

- laser ranging systems involved in ILRS: Wettzell Laser Ranging System (WLRS) and a new implementation called Satellite Observing System Wettzell (SOS-W), which is under construction.
- GPS receivers involved in the global network IGS, in the European network EUREF, in the national network GREF, and in time transfer experiments.
- G, a large laser gyroscope or ringlaser, dedicated for monitoring of daily variations of Earth rotation.
- local techniques, such as time and frequency, meteorology, super conducting gravity meter, water vapor observations, and a regularly operated local surveying system.

Within the responsibility of the GOW are also the TIGO system in Concepción, Chile, mainly together with the Universidad de Concepción, and the German Antarctic Receiving Station (GARS) O'Higgins in Antarctica, together with the German Space Center (DLR) and the Institute for Antarctic Research Chile (INACH).

## 2. Staff

The staff of the GOW consists of, in total, 33 members for operations, maintenance, repair issues, and the improvement and development of the systems. The staff operating RTW is summarized in Table 1.

## 3. Observations in 2009

The 20-m RTW has supported geodetic VLBI activities—e.g., of the International VLBI Service for Geodesy and Astrometry and other partners, such as the EVN—for over 25 years. All successfully observed sessions in the year 2009 are summarized in Table 2. According to the IVS 2009 Master Schedule, RTW was the most utilized network station for 24-hour geodetic VLBI sessions. The daily one-hour Intensive sessions (INT), that are run in order to determine UT1-UTC,

Table 1. Staff - members of RTW

Name	Affiliation	Function	Working for
Johannes Ihde	BKG	interim head of the GOW (until June 2009)	GOW
Ullrich Schreiber	BKG	head of the GOW (July to December 2009)	GOW
Alexander Neidhardt	FESG	head of the RTW group and VLBI station chief	RTW, SOSW (partly O'Higgins)
Erhard Bauernfeind	FESG	mechanical engineer	RTW
Ewald Bielmeier	FESG	technician	RTW
Gerhard Kronschnabl	BKG	electronic engineer	RTW (partly TIGO and O'Higgins)
Christian Plötz	BKG	electronic engineer	O'Higgins, RTW
Raimund Schatz	FESG	software engineer	RTW
Walter Schwarz	BKG	electronic engineer	RTW (partly O'Higgins and WVR)
Reinhard Zeitlhöfler	FESG	electronic engineer	RTW
Daniel Helmbrecht	FESG/BKG	student (January to May 2009)	RTW
Alexander Bauer	FESG/BKG	student	RTW
Thomas Guggeis	FESG/BKG	student (August to December 2009)	RTW

were continued in addition to the 24-hour sessions. For these sessions the complete data transfer is done with e-VLBI techniques. RTW now routinely uses the increased Internet connection capacities of 622 Mbit/sec for the e-transfers to Bonn, Tsukuba, and Haystack. According to the implementation of a field system extension for remote control, weekend Intensives were done by remote attendance or completely unattended. In addition to the standard sessions, RTW also participated in the IYA09, which was an astrometric session for the International Year of Astronomy 2009.

In addition, the ESA Venus Express spacecraft was observed at X-band with the Wettzell radiotelescope in October–December 2009 in the framework of a study to assess the possible contribution of the European VLBI network to the upcoming ESA deep space missions. The first goal of these observations was to develop and test the scheduling, data capture, transfer, processing, and analysis pipeline. The high dynamic range of the detections allowed the achievement of a mHz level of spectral resolution accuracy and the extraction of the phase of the spacecraft signal carrier line. Apart from other important results, the measured phase fluctuations of the carrier line at different time scales can be used to determine the influence of the Solar wind plasma density fluctuations on the accuracy of the astrometric VLBI observations.

Table 2. RTW observations in 2009

program	number of 24h-sessions	program	number of 1h-sessions
IVS R1	50	INT1(Kokee-RTW)	236
IVS R4	51	INT2/K(Tsukuba-RTW)	103
IVS T2	7	INT3/K(Tsukuba-RTW-NyAl)	48
IVS R&D	9	<b>total (in hours)</b>	<b>387</b>
RDV/VLBA	6		
EUROPE	6	<b>special program</b>	<b>in hours</b>
IYA09	1	VENUS Express (7 obs.)	7
<b>total</b>	<b>130</b>	Test Mark 5B Crimea	1
<b>total (in hours)</b>	<b>3120</b>	<b>total (in hours)</b>	<b>8</b>

#### 4. Technical Improvements and Maintenance

VLBI observations require high reliability of all participating stations. Therefore careful servicing of all components is essential to ensure successfully performed VLBI measurements throughout the year. Additionally the 20-m RTW has to be kept at a high technical standard and has to be improved according to technological advancements.

In 2009 the following developments and maintenance tasks were done:

- Test setup of the new Digital Baseband Converter (DBBC)
  - running of test schedules and data acquisitions
  - writing of controlling code to run the DBBC via Ethernet
- Continued software implementations for a remotely controllable extension for the NASA Field System
  - regular uses with RTW
  - preparing an official release to offer the basic software also for other telescopes
- Permanent reference point determination with laser tracker, tachymeter, and leveling instrument on the basis of a new mathematical model done by Michael Lösler (Geodetic Institute of the University Karlsruhe, Germany)
  - installation of a tachymeter for three months to monitor the movements of the reference point permanently
  - installation of a scintillometer for refraction calibration
  - collecting additional information—e.g., meteorological data or invar cable measurements
  - experiments with additional equipment, such as a laser tracker and a leveling instrument, while moving the telescope
  - an internal report from Lösler shows a reference point stability of about 15/100 to 20/100 mm over one day

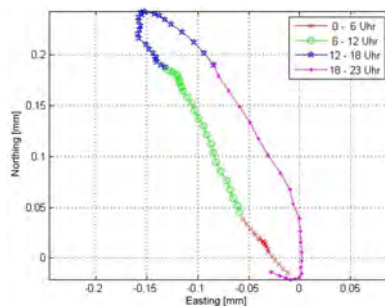

Figure 1. Estimated daily variation of reference point (M. Lösler)

- Calculation of orbits for Global Navigation Satellite Systems satellites for observations at partner telescopes

- Completion of the mechanical work at the replacement dewar and commencement of the testing phase
- Regular tasks and maintenance days (obtaining replacements for the hardware, 8-pack repairs, gear maintenance, Field System updates, cryo system maintenance, servo replacements, and improvements by using EVN-PCs for e-VLBI issues)
- IVS VLBI2010 Workshop on Future Radio Frequencies and Feeds (FRFF)
  - 60 international scientists discussed the new developments for VLBI2010 in Wettzell/Höllenstein in March 2009
  - Discussions about the new Eleven feed from Prof. Kildal (Chalmers University Göteborg/Sweden)
  - Presentations of the new design of the TWIN radiotelescopes Wettzell
  - Results offered guidelines for the future developments (frequencies, bands, developments, digital backends and so on)
- Building of the new TWIN radiotelescope Wettzell (TTW)
  - final project design and design review with fixation of the construction
  - design of the operation building
  - construction of the new towers and the control building started in September 2009



Figure 2. Construction of the concrete tower for the TWIN telescopes

## 5. Plans for 2010

During 2010, dedicated plans are:

- Usage of the digital baseband converters (DBBC)
- Extension of the software developments for remote control and the NASA Field System extension
- Continuous construction of the VLBI2010 TWIN-telescopes
- Integration of the Wettzell system monitoring at the RTW
- Plans to replace the existing radar system at the laser ranging system with a solution that conforms to VLBI2010

## Instituto Geográfico Nacional of Spain

*Francisco Colomer, Pablo de Vicente, Jesús Gómez–González,  
José Antonio López–Fernández, Susana García Espada*

### Abstract

This report updates the description of the OAN facilities as an IVS network station. The new 40-m radiotelescope has performed geodetic VLBI observations regularly since September 2008. Commissioning continues in particular for short wavelengths (3 mm). Yebes will become one of the new Space Geodynamics Stations in the RAEGE project, with the construction of a new radiotelescope of VLBI2010 specifications and an SLR facility in the near future.

### 1. General Information: the IGN Facilities at Yebes

The Yebes radiotelescopes (the new 40-m and the old 14-m which was an IVS network station since 2003 and is now being refurbished for VSOP-2) are located at the currently named “Technological Development Center” (CDT-Yebes), a department of the Instituto Geográfico Nacional (IGN, Ministerio de Fomento) together with the National Astronomical Observatory (OAN).

Yebes CDT is also the reference station for the Spanish GPS network and holds new facilities for gravimetry. As explained later in detail, the RAEGE project, which will build four Fundamental Geodynamical stations, will soon provide a new VLBI2010-type antenna in Yebes, together with an SLR system in a new control building.

### 2. IGN-OAN Staff Working on VLBI Projects

Table 1 lists the OAN staff who are involved in geodetic VLBI studies and operations. The VLBI activities are also supported by other staff such as receiver engineers, computer managers, secretaries, and students. Hiring of dedicated telescope operators is completed and available in Yebes in the first quarter of 2010.

Table 1. Staff in the OAN VLBI group (Email: [vlbitech@oan.es](mailto:vlbitech@oan.es)).

Name	Background	Role	Address*
Francisco Colomer	Astronomer	VLBI Project coordinator	OAM, IGN
Susana García-Espada	Engineer	Ph.D. student	CAY
Jesús Gómez–González	Astronomer	Deputy Director for Astronomy, Geodesy and Geophysics	IGN
José Antonio López–Fdez	Engineer	CAY site manager	CAY
Pablo de Vicente	Astronomer	VLBI Technical coordinator	CAY

#### Addresses:

**OAM:** Observatorio Astronómico de Madrid. Calle Alfonso XII, 3. E–28014 Madrid, Spain.

**CAY:** Centro Astronómico de Yebes. Apartado 148, E–19080 Guadalajara, Spain.

**IGN:** Instituto Geográfico Nacional. Calle General Ibañez de Ibero 3, E–28003 Madrid, Spain.



Table 2. Characteristics of the Yebes 40-m geodetic VLBI station.

Parameter	Value	DAR	VLBA5 (14) + VSI-C
Diameter	40 meter	Recorder	Mark 5B
Receivers	2 - 115 GHz	H-maser	T4-Science iMaser 3000
S/X $T_{\text{sys}}$	180/60 K	GPS	TrueTime XL-DC
S/X SEFD	800/200 Jy	Weather station	SEAC-EMC

### 3. Status of Other Geodetic VLBI Activities at OAN

The 40-m radiotelescope has participated regularly in IVS geodetic VLBI campaigns, except during the summer due to a failure of the H-maser. In total, 16 campaigns were observed, and 3 were lost because of this problem.

The connection of Yebes to GÉANT at 1 Gbps, thanks to the EC project EXPReS, has been fully operational since April 2009.

A new Hydrogen maser has been purchased, to replace the Russian KVART-73 maser which failed in 2009 after 13 years of successful operation.

An absolute gravimeter is now permanently placed at the new building in Yebes. A superconducting gravimeter is expected in April 2010.



Figure 1. Absolute gravimeter at the new building in Yebes.

The new  $\lambda = 3$  mm receiver was installed at the 40-m cabin, and first light was obtained in December 2009. This receiver will be mostly used for single dish and VLBI astronomical studies.

Cooperation with the geodesy group at Onsala Space Observatory in Sweden progresses by modeling the tropospheric effect caused by neutral atmosphere using the HIRLAM 3D-VAR numerical weather prediction model, where a direct improved mapping function is calculated using raytracing. Preliminary results will be presented at the IVS 2010 General Meeting in Hobart (Australia).

#### 4. Future Plans: Project RAEGE

IGN intends to construct a network of four new Fundamental Geodynamical Stations in Spain and Portugal (see Figure 2). This project, named *RAEGE* (after “**R**ed **A**tlántica de **E**staciones **G**eodinámicas y **E**spaciales”), consists of the erection in Yebes (1), Canary Islands (1), and Azores Islands (2), of one radiotelescope of VLBI2010 class (i.e. of 12-m diameter, high slew rate, capable of operating in the 2-18 GHz bands), a permanent GNSS receiver, a superconducting gravimeter, and (at least in Yebes) an SLR station. The construction of the first three stations (in Yebes, Gran Canaria, and Azores-Santa María) will start in 2010.



Figure 2. Location of the new stations in the RAEGE project.

#### References

- [1] Barbas L., Bolaño R., de Vicente P. “Java Field System Log File Client”. Informe Técnico OAN 2009-8 (see <http://www1.oan.es/informes/archivos/IT-OAN-2009-7.pdf>).
- [2] de Vicente, P. “How to run a VLBI observation with the 40m radiotelescope”. Informe Técnico OAN 2009-7 (see <http://www1.oan.es/informes/archivos/IT-OAN-2009-7.pdf>).
- [3] García-Espada S., Colomer F., Haas R. “Simulations of Different Antenna Velocities in VLBI Networks”. 2009. Proceedings of the 19<sup>th</sup> European VLBI for Geodesy and Astrometry Working Meeting, 24-25 March 2009, Bordeaux. G. Bourda, P. Charlot, A. Collioud (Eds), p. 169-172.
- [4] Gómez-González J., Colomer F., López-Fernández J.A. “An Atlantic Network of Geodynamical and Space Stations (Project RAEGE)”. 2009. Proceedings of the 19<sup>th</sup> European VLBI for Geodesy and Astrometry Working Meeting, 24-25 March 2009, Bordeaux. p. 133.



Figure 3. Elements of the future RAEGE station in Yebes (Guadalajara, Spain).

# Zelenchujskaya Radio Astronomical Observatory

*Andrei Dyakov, Sergey Smolentsev*

## Abstract

This report briefly summarizes the observational activities at the Zelenchujskaya observatory during the year 2009.

## 1. General Information

Zelenchujskaya Radio Astronomical Observatory (ZcRAO) was founded by Institute of Applied Astronomy (IAA) as one of three stations of the Russian VLBI network QUASAR. The sponsoring organization of the project is the Russian Academy of Sciences (RAS). The Zelenchujskaya Radio Astronomical Observatory is situated in the Republic Karachaevo-Cherkessiya (Northern Caucasia) about 70 km south of Cherkessk, near to the Zelenchujskaya site (not far from Radiotelescope RATAN-600). The geographic location of the observatory is shown on the IAA RAS Web site: [http://www.ipa.nw.ru/PAGE/koi8-r/DEPOBSERV/rus\\_zel.htm](http://www.ipa.nw.ru/PAGE/koi8-r/DEPOBSERV/rus_zel.htm). The basic instruments of the observatory are a 32-m radio telescope and technical systems provided for the realization of VLBI observations (see Fig. 1).



Figure 1. Zelenchujskaya Observatory.

Table 1. Zelenchujskaya Observatory location and address.

Longitude	41°34'
Latitude	43°47'
Zelenchujskaya Observatory	
Republic Karachaevo-Cherkessia	
369140, Russia	
ipazel@mail.svkchr.ru	

## 2. Technical and Scientific Information

The technical parameters of the radiotelescope RT-32 and the ZcRAO equipment are presented in Table 2.

The data acquisition system VLBA-4 is equipped with recording terminals Mark 5B, Mark 5A, and RDR-1 (for the RADIOASTRON mission).

The permanent GPS receiver ASHTECH Z-X113 with an ASH 700936D.M antenna Dorne-Margolin/Choke Ring was installed at the observatory in 2006. Observed data are sent to BKG and IGS every hour.

Table 2. Technical parameters of the radio telescope.

Year of construction	2000
Mount	AZEL
Azimuth range	$\pm 270^\circ$ (from south)
Elevation range	from $-5^\circ$ to $95^\circ$
Maximum azimuth	
- velocity	$1.5^\circ/\text{s}$
- tracking velocity	$1.5'/\text{s}$
- acceleration	$0.2^\circ/\text{s}^2$
Maximum elevation	
- velocity	$0.8^\circ/\text{s}$
- tracking velocity	$1.0'/\text{s}$
- acceleration	$0.2^\circ/\text{s}^2$
Pointing accuracy	better than $10''$
Configuration	Cassegrain (with asymmetrical subreflector)
Main reflector diameter	32 m
Subreflector diameter	4 m
Focal length	11.4 m
Main reflector shape	quasi-paraboloid
Subreflector shape	quasi-hyperboloid
Surface tolerance of main reflector	$\pm 0.5$ mm
Frequency capability	1.4–22 GHz
Axis offset	$-11.5 \pm 0.5$ mm

## 3. Technical Staff

Andrei Dyakov — Observatory chief,  
 Dmitry Dzuba — FS, pointing system controls,  
 Anatoly Mishurinsky — front end and receiver support.

#### 4. Current Status and Activities

ZcRAO participates in IVS and Russian Domestic VLBI observations. Table 3 summarizes the IVS VLBI sessions performed during 2009 at ZcRAO: in all 59 IVS sessions, including 13 IVS-R1, 38 IVS-R4, 1 EUROPE, 2 IVS-T2, 1 IYA09, and 4 VLBA sessions.

Table 3. List of IVS sessions observed at ZcRAO in 2009.

Month	IVS-R1	IVS-R4	VLBA	T2	EURO	IYA09
January	2	2	1			
February		3				
March	2	4				
April		4	1			
May	2	3				
June		3		1		
July	1	3	1			
August	1	2		1		
September	1	3			1	
October	1	3				
November	1	3				1
December	2	5	1			
Total	13	38	4	2	1	1

During 2009 the Zelenchukskaya observatory participated in VLBI observations of the QUASAR network: in 20 Ru-E sessions (24-hour sessions for EOP monitoring) and 28 Ru-U sessions (4 1-hour sessions for UT1 measurement); 17 of these were provided in e-VLBI mode. In April 2009, the first e-VLBI sessions were successfully carried out. Since September 2009 the Ru-U sessions for UT1 have been held in e-VLBI mode.

In 2009 the electronic part of the hydrogen maser CH1-80 was upgraded. A modernized hydrogen maser CH1-80M has been installed at Zelenchukskaya observatory.

Reflector alignment was performed at Zelenchukskaya RAO in 2009; the surface rms was 0.47 mm after that.

#### 5. Outlook

Our plans for the coming year are the following:

- Participation in 34 IVS observing sessions: IVS-R4, IVS-T2, VLBA and EURO.
- Participation in weekly domestic observational sessions for obtaining Earth orientation parameters and in weekly 1-hour e-VLBI sessions for UT1 determination.
- Surveying the local geodetic network.
- GPS Javad receiver installation.
- Preparation for laser ranging system installation.
- Participation in EVN observations.



Operation Centers

Operation Centers





# The Bonn Geodetic VLBI Operation Center

*A. Nothnagel, A. Müssens*

## Abstract

The IGGB Operation Center has continued to organize and schedule the IVS-T2, IVS-OHIG, IVS-INT3, and EUROPE sessions.

## 1. Center Activities

The IGGB VLBI Operation Center is located at the Institute of Geodesy und Geoinformation of the University of Bonn, Nussallee 17, D-53115 Bonn, Germany. It has been organizing and scheduling VLBI observing sessions for more than twenty years. The observing series organized and scheduled in 2009 are the same as in 2008.

- **Measurement of Vertical Crustal Motion in Europe by VLBI (EUROPE)**

In Europe, a series of special sessions has been scheduled for the determination of precise station coordinates and for long term stability tests. This year, six sessions with Ny-Ålesund, Onsala, Metsahovi, Svetloe, Zelenchukskaya, Badary, Effelsberg, Wettzell, Simeiz, Madrid (DSS65A), Medicina, Matera, Noto, and Yebes were scheduled employing the frequency setup of 16 channels and 4 MHz bandwidth in fan-out mode (identical to the setup of the IVS-T2 sessions).

- **IVS-T2 series**

This series has been observed roughly every other month (7 sessions in 2009) primarily for maintenance and stabilization of the VLBI terrestrial reference frame, as well as for Earth rotation monitoring as a by-product. Each station of the global geodetic VLBI network is planned to participate at least once per year in the T2 sessions. In view of the limitations in station days, priority was given to stronger and more robust networks with many sites over more observing sessions. Therefore, 12 to 15 stations have been scheduled in each session requiring multiple passes on the IVS correlators. The scheduling of these sessions has to make sure that a sufficient number of observations is planned for each baseline of these global networks. The recording frequency setup is 16 channels and 4 MHz channel bandwidth.

- **Southern Hemisphere and Antarctica Series (OHIG)**

Seven sessions of the Southern Hemisphere and Antarctica Series with the Antarctic stations Syowa (Japanese) and O'Higgins (German) plus Fortaleza, Hobart, Kokee, and DSS45 have been organized for maintenance of the VLBI TRF and for Earth rotation monitoring. These sessions are clustered in time at periods when O'Higgins is manned depending on logistical circumstances and available manpower. The recording frequency setup is 16 channels and 4 MHz channel bandwidth. Due to the fact that Syowa is not able to deliver the recorded data for nearly one year after the observations, the correlation and the generation of the databases is delayed considerably.

- **UT1 determination with near-real-time e-VLBI (INT3)**

The so-called INT3 sessions included the telescopes of Ny-Ålesund, Tsukuba, and Wettzell for weekly UT1 determination with rapid processing time. Since August 2007 these sessions have been scheduled to start every Monday morning at 7:00 a.m. UT.

In order to speed up delivery of the results, the raw VLBI observation data of the three sites is transferred to the Bonn Correlator by Internet connections. The transmission rate is about 100 Mb/s for Ny-Ålesund (limited due to the use of a radio link for the first part of the distance) and 400 Mb/s from Tsukuba and Wettzell. For compatibility reasons, the data of Tsukuba initially recorded in K4 format has to be converted to Mark 5 format after transmission. 16 channels with 8 MHz/channel are recorded resulting in 256 Mb/s. With close to 30 minutes effective observing and recording time, each station has to transfer about 460 Gb or 58 GB per session. Due to copying procedures and current network capacities, the threshold for completion of delivery of the raw VLBI data to the correlator is currently about seven hours after the final observation. In 2009, 49 sessions have been observed and transmitted successfully. 80% of the sessions have been correlated and delivered within the first 8 hours after the end of the observations. A further 15% have been completed within 10 hours. The rest have taken between 10 and 24 hours due to difficulties with networking hardware.

## 2. Staff

Table 1. Personnel at IGGB Operation Center

Arno Müskens	+49-228-525264	mueskens@mpifr-bonn.mpg.de
Axel Nothnagel	+49-228-733574	nothnagel@uni-bonn.de

# CORE Operation Center Report

*Cynthia C. Thomas, Daniel MacMillan*

## Abstract

This report gives a synopsis of the activities of the CORE Operation Center from January 2009 to December 2009. The report forecasts activities planned for the year 2010.

## 1. Changes to the CORE Operation Center's Program

The Earth orientation parameter goal of the IVS program is to attain precision at least as good as  $3.5 \mu\text{s}$  for UT1 and  $100 \mu\text{as}$  for pole position.

The IVS program, which started in 2002, used the Mark IV recording mode for each session. The IVS program began using the Mark 5 recording mode in mid-2003. By the end of 2007, all stations were upgraded to Mark 5. Due to the efficient Mark 5 correlator, the program continues to be dependent on station time and media. The following are the network configurations for the sessions for which the CORE Operation Center was responsible in 2009:

IVS-R1: 52 sessions, scheduled weekly and mainly on Mondays, six to eight station networks

RDV: 6 sessions, scheduled evenly throughout the year, 15 to 16 station networks

IVS-R&D: 10 sessions, scheduled monthly, five to seven station networks

## 2. IVS Sessions from January 2009 to December 2009

This section displays the purpose of the IVS sessions for which the CORE Operations Center is responsible.

- IVS-R1: In 2009, the IVS-R1s were scheduled weekly with six to eight station networks. There were seven stations that participated in at least half of the scheduled sessions—Ny-Ålesund, Westford, Tigo, Hobart, Kokee, Tsukuba, and Wettzell. Both Badary and Zelenchukskaya were tagged along to all 13 IVS-R1 sessions in which the two stations participated.

The purpose of the IVS-R1 sessions is to provide weekly EOP results on a timely basis. These sessions provide continuity with the previous CORE series. The “R” stands for rapid turnaround because the stations, correlators, and analysts have a commitment to make the the time delay from the end of recording to the results as short as possible. The time delay goal is a maximum of 15 days. Participating stations are requested to ship discs to the correlator as rapidly as possible. The “1” indicates that the sessions are mainly on Mondays.

- RDV: There are six bi-monthly coordinated astrometric/geodetic experiments each year that use the full 10-station VLBA plus up to 8 geodetic stations.

These sessions are being coordinated by the geodetic VLBI programs of three agencies: 1. USNO will perform repeated imaging and correction for source structure; 2. NASA will analyze this data to determine a high accuracy terrestrial reference frame; and 3. NRAO will use these sessions to provide a service to users who require high quality positions for a

small number of sources. NASA (the CORE Operation Center) prepares the schedules for the RDV sessions.

- R&D: The purpose of the 10 R&D sessions in 2009, as decided by the IVS Observing Program Committee, was as follows. The purpose of session one and sessions three through six was to determine the positions of some sources that do not have good positions. The purpose of session two was to support the “target of opportunity” observation of the close approach of Saturn to a compact radio source (1125+062). The purpose of sessions seven through ten was to improve the technique used to schedule the Intensive sessions.

### 3. Current Analysis of the CORE Operation Center’s IVS Sessions

Table 1 gives the average formal errors for the R1, R4, RDV, and T2 sessions from 2009. The R1 sessions’ formal uncertainties appear to be following a trend of becoming worse over the three years 2007-2009. The most likely reason is network differences, but this should be investigated. On the other hand, uncertainties for the 2009 R4 sessions are generally about the same as for 2007-2008.

The RDV uncertainties are better in 2009 than in the preceding two years. This is not explained by network size since there were 15-16 sites in 2007 and 2009 and 17-18 sites in 2008, but it is possible that network geometry has an effect.

Table 2 shows the EOP differences with respect to IGS for the R1, R4, T2, and RDV series. The WRMS differences were computed after removing a bias, but estimating rates does not affect the residual WRMS significantly. The RDV series have the best WRMS agreement with IGS in 2009 as well as for sessions since 2000. The R1 series show worse WRMS agreement (X-pole and Y-pole) for 2009 than for the R1 series since 2000. This is consistent with the formal error trend. For all session types, the level of LOD WRMS agreement in 2009 is better than the LOD WRMS agreement for all sessions of that type since 2000. There are some significant biases greater than 100  $\mu\text{as}$  between the VLBI and the GPS series that should be investigated.

Table 1. Average EOP Formal Uncertainties for 2009

Session Type	Num	X-pole ( $\mu\text{as}$ )	Y-pole ( $\mu\text{as}$ )	UT1 ( $\mu\text{s}$ )	DPSI ( $\mu\text{as}$ )	DEPS ( $\mu\text{as}$ )
R1	52	59(56,45)	59(51,43)	2.2(2.4,1.9)	124(109,82)	50(42,33)
R4	52	69(72,69)	73(79,73)	2.6(2.8,2.9)	175(176,162)	66(73,68)
RDV	5	38(43,50)	39(45,53)	1.7(2.2,2.8)	71(77,92)	27(30,41)
T2	2	44(53,44)	48(66,49)	2.2(2.7,2.2)	103(127,107)	40(55,36)

Values in parentheses are for 2008 and then 2007

### 4. The CORE Operations Staff

Table 3 lists the key technical personnel and their responsibilities so that everyone reading this report will know whom to contact about their particular question.

Table 2. Offset and WRMS Differences (2009) Relative to the IGS Combined Series

Session Type	Num	X-pole		Y-pole		LOD	
		Offset ( $\mu$ as)	WRMS ( $\mu$ as)	Offset ( $\mu$ as)	WRMS ( $\mu$ as)	Offset ( $\mu$ s/d)	WRMS ( $\mu$ s/d)
R1	52(408)	-49(22)	115(94)	127(88)	104(95)	-2(1)	15(17)
R4	52(407)	-12(-18)	107(109)	86(82)	118(110)	-2(1)	17(19)
RDV	5(77)	-68(73)	85(87)	174(129)	78(89)	-7(1)	7(15)
T2	3(62)	19(36)	68(134)	229(52)	93(124)	12(2)	11(20)

Values in parentheses are for the entire series (since 2000) for each session type

Table 3. Key Technical Staff of the CORE Operations Center

Name	Responsibility	Agency
Dirk Behrend	Organizer of CORE program	NVI, Inc./GSFC
Brian Corey	Analysis	Haystack
Irv Diegel	Maser maintenance	Honeywell
Mark Evangelista	Receiver maintenance	Honeywell
John Gipson	SKED program support and development	NVI, Inc./GSFC
Frank Gomez	Software engineer for the Web site	Raytheon/GSFC
David Gordon	Analysis	NVI, Inc./GSFC
Ed Himwich	Network Coordinator	NVI, Inc./GSFC
Dan MacMillan	Analysis	NVI, Inc./GSFC
David Rubincam	Procurement of materials necessary for CORE operations	GSFC/NASA
Braulio Sanchez	Procurement of materials necessary for CORE operations	GSFC/NASA
Dan Smythe	Tape recorder maintenance	Haystack
Cynthia Thomas	Coordination of master observing schedule and preparation of observing schedules	NVI, Inc./GSFC

## 5. Planned Activities during 2010

The CORE Operation Center will continue to be responsible for the following IVS sessions during 2010.

- The IVS-R1 sessions will be observed weekly and recorded in a Mark 5 mode.
- The IVS-R&D sessions will be observed 10 times during the year.
- The RDV sessions will be observed 6 times during the year.

# NEOS Operation Center

*Kerry Kingham, M.S. Carter*

## Abstract

This report covers the activities of the NEOS Operation Center at USNO for 2009. The Operation Center schedules IVS-R4 and the INT1 Intensive experiments.

## 1. VLBI Operations

In the period covered, NEOS operations consisted, each week, of one 24-hour duration IVS-R4 observing session, on Thursday-Friday, for Earth Orientation, together with five daily one-hour duration “Intensives” for UT1 determination, Monday through Friday. In 2009, the operational IVS-R4 network included VLBI stations at Kokee Park (Hawaii), Wettzell (Germany), Fortaleza (Brazil), Ny-Ålesund (Norway), TIGO (Chile), Svetloe, Badary and Zelenchukskaya (Russia), Hobart (Australia), Yebes (Spain), and Matera and Medicina (Italy). A typical R4 consisted of five to eight stations.

The regular stations for the weekday IVS Intensives were Kokee Park and Wettzell. Intensives including Kokee Park, Wettzell, and Svetloe were observed twice per month in order to characterize the Kokee Park – Svetloe baseline so that Svetloe can be used as an alternate for Wettzell should it be needed.

The Operations Center updated the version of sked as updates were available.

All sessions are correlated at the Washington Correlator, which is located at USNO and is run by NEOS.

Table 1. Experiments Scheduled during 2009

52	IVS-R4 experiments
217	Intensives (Kk–Wz)
20	Kk-Sv-Wz Intensives

## 2. Staff

K. A. Kingham and M. S. Carter are the only staff members of the NEOS Operation Center. Kingham is responsible for the overall management, and Carter makes the schedules. M. S. Carter is located at the USNO Flagstaff Station (NOFS).



Figure 1. U.S. Naval Observatory Flagstaff Station, location of half of the Operations Center







Correlators



Correlators



# The Bonn Astro/Geo Mark IV Correlator

*Simone Bernhart, Alessandra Bertarini, Arno Müskens, Walter Alef*

## Abstract

The Bonn Mark IV VLBI correlator is operated jointly by the MPIfR and the IGG in Bonn and the BKG in Frankfurt. Since 2007, e-VLBI transfers have become routine for geodetic experiments and, thanks to that, an Intensive series (INT3) was introduced and is correlated in Bonn. The hardware Mark IV processor system has not been changed since the last report except for the addition of another Mark 5B unit. In late December 2007, the first phase of a Linux cluster dedicated for the software correlator was installed. The cluster was extended in January 2009 after new infrastructure for sound insulation, electrical power, and cooling had been built in the correlator room. Astronomical correlation has been moved to the DiFX correlator.

## 1. Introduction

The Bonn Mark IV correlator is hosted at the Max-Planck-Institut für Radioastronomie (MPIfR)<sup>1</sup> Bonn, Germany. It is operated jointly by the MPIfR and the Bundesamt für Kartographie und Geodäsie (BKG)<sup>2</sup> in cooperation with the Institut für Geodäsie und Geoinformation der Universität Bonn (IGG)<sup>3</sup>. It is a major correlator for geodetic observations and MPIfR's astronomical projects, for instance those involving millimeter wavelengths and astrometry. Production astronomical correlation has been moved to the DiFX software correlator in autumn 2009, while geodetic correlation is still ongoing on the Mark IV.

## 2. Present Correlator Capabilities

The Bonn correlator is one of the four Mark IV VLBI data processors in the world. It has been operational since 2000. It currently consists of a standard Mark IV correlator rack, 7 Mark 5A units, 4 Mark 5B units, and one additional unit dedicated to e-VLBI, which can also be used as a Mark 5A unit. All Mark 5s and a further Mark 5C unit are also connected to the software correlator. Capabilities of the Mark IV correlator can be found in Table 1. A Linux file server stores all files related to the correlation of the data. The correlator is controlled by a dedicated Linux workstation and an HP workstation, both connected to the Linux file server. Correlation setup, data inspection, fringe-fitting and data export are done on a second Linux machine connected to the Linux file sever. Data security is guaranteed by using a file system with redundancy (RAID level 5) and by daily back-up of the data on a PC disk.

Key parameters of the software correlator cluster are:

- 60 nodes with 8 compute cores each (480 cores total)
- 4 TFlops (floating point operations) in the Linpack benchmark test
- Infiniband 20 Gb interconnect
- two times 1 Gb Ethernet interconnect

---

<sup>1</sup><http://www.mpifr-bonn.mpg.de/div/vlbicor/>

<sup>2</sup><http://www.bkg.bund.de/>

<sup>3</sup><http://www.gib.uni-bonn.de/>

- two 20 GB raid systems
- FXmanager control computer which is the control node for the correlator
- Frontend control computer for users who use the cluster for other tasks than correlation
- Appliance control computer for installing and monitoring the cluster
- closed loop rack cooling

Table 1. Correlator Capabilities

## PLAYBACK UNITS

Number available: 7 Mark 5A systems, 4 Mark 5B systems  
 Playback speeds: real-time up to 1024 Mb/s  
 (2024 Mb/s slowed down by a factor of 2)

## SUPPORTED RECORDING

Record data-rates: any supported by Mark 5  
 Formats: Mark III/Mark IV/VLBA (Mark IV/VLBA w/wo barrel roll, data demod.)  
 Sampling: 1 or 2-bit (over-sampling not yet tested)  
 Fan-out: 1:1 1:2 1:4 (fan-in not supported)  
 No. of channels:  $\leq 16$ , USB and/or LSB  
 Bandwidth/channel: ....2, 4, 8, 16 MHz  
 Signals: mono, dual frequency or dual polarization  
 Modes: Mark III: B, C, BB, CC; A, AA (in 2 passes)  
 128-16-1 128-16-2 128-8-1 128-8-2 128-4-1 128-4-2  
 128-2-2 256-16-1 256-16-2 256-8-1 256-8-2 256-4-2  
 512-16-2 512-8-2 1024-16-2 2048 Mb/s with Mark 5B+

## CORRELATION

Geometric model: CALC 8  
 Number of boards: 16 (DSP not yet implemented)  
 Phasecal: dual tone extraction at selectable freqs (single tone analyzed)  
 Pre-average times: 0.2  $\rightarrow$  5 s (default 2 s; 60/N s, N an integer; short  
 integration times not with full correlator capacity)  
 Lags per channel: 32 min. ( $\Rightarrow$  frequency resolution = BW/16), 1024 max.  
 Maximum output: 8 stations: 28 baselines, 16 channels, 32 lags with ACF and  
 full cross polarization  
 10 stations tested with single polarization and ACF  
 (requires mixture of Mark 5A and 5B)  
 Multiple streams: Maximum of 4 independent correlations for  
 simultaneous correlation of sub-nets, etc.  
 Multiple passes: Depends on mixture of 5A and 5B.  
 Up to 16 stations in 6 passes or less.  
 Fringe-fit: Off-line FOURFIT run. (Dual frequency in single  
 execution: dual/cross-polsn. in multiple executions)  
 Export: Database, MK4IN to AIPS

VLBI data can be played into the cluster from 13 Mark 5 recorders via 1 Gb Ethernet. If more than 13 playbacks are required and in the case of e-VLBI, data is copied to the raid systems before correlation.

### 3. Staff

The people in the geodetic group at the Bonn correlator are:

**Arno Müskens** - group leader, scheduling of T2, OHIG, EURO, and INT3, and e-VLBI supervisor.

**Alessandra Bertarini** - experiment setup and evaluation of correlated data, software correlator development. Digital baseband converter (DBBC) testing. PhD student at IGG Bonn since early 2007, subject of the thesis: Effects on the geodetic VLBI measurables due to polarization leakage in the receivers.

**Simone Bernhart** - e-VLBI operations, experiment setup and evaluation of correlated data, media shipping. PhD student at the MPIfR since September 2003, subject of the thesis: Flux Density and Kinematic Measurements of the IDV Source 0917+624.

**Laura La Porta** - experiment setup and evaluation of correlated data.

**Bertalan Feher** - setup and trial correlation of INT3 (until September 2009).

**Rene Böckelmann** - setup and trial correlation of INT3 (since October 2009).

**Frédéric Jaron** - phasecal extraction for software correlator, software support and Web page maintenance.

**Six student operators** for the night shifts and the weekends.

The people in the astronomy group of MPIfR at the Bonn correlator who support IVS correlation are:

**Walter Alef** - head of the VLBI technical department, correlator software maintenance and upgrades, computer system and cluster administration. Friend of the correlator.

**David Graham** - technical development, consultant, DBBC development and testing.

**Alan Roy** - deputy group leader, instrument scientist (water vapor radiometer, technical assistance, development of FPGA firmware for linear to circular polarization conversion, project manager for equipping APEX for millimeter VLBI).

**Helge Rottmann** - software correlator development and operation. Cluster administration.

**Heinz Fuchs** - correlator operator, responsible for the correlator operator schedule, daily operations and media shipping.

**Hermann Sturm** - correlator operator, correlator support software, media shipping and Web page development.

**Michael Wunderlich** - engineer, technical VLBI developments, Mark IV correlator and Mark 5 maintenance.

**Rolf Märten** - technician maintaining correlator hardware and Mark 5 playbacks.

**Marcus Offermanns** - DBBC production and testing.

**Gino Tuccari** - guest scientist from INAF, DBBC development, DBBC project leader.

### 4. Status

**Experiments:** In 2009 the Bonn group correlated 52 R1, five EURO, three T2, six OHIG, 49 INT3, and about 30 astronomical experiments.

**e-VLBI:** e-transfers are performed on a regular basis from Tsukuba, Ny-Ålesund, Onsala, Metsähovi, Wettzell, Kashima (including data of the Antarctic Syowa station), Aira, and Chichijima to Bonn. Data from Japanese VERA stations Mizusawa and Ishigakijima have successfully been transferred to Bonn (from Mitaka and Tsukuba, respectively) for the first time in 2009. e-transfer reduces the time between observation and correlation since no shipment is required. The data rates achieved range from 100 Mb/s with Ny-Ålesund (limited by radio link) to 600 Mb/s with peaks up to 800 Mb/s (with Kashima). The transfers are done using the UDP-based Tsunami protocol. The total disk space available for e-VLBI data storage at the correlator is currently about 26.8 Tbyte.

**INT3:** The third Intensive series (INT3), which was introduced in late summer 2007, is scheduled and correlated in Bonn every Monday. Thanks to near-real-time e-VLBI transfer, the turnaround between observation and database submission to the analysis center is about seven hours.

**Hardware Correlator:** In 2009, the Mark 5A unit, which was previously used for e-VLBI, has been linked to the correlator as an additional Mark 5B unit. Instead, one of the Mark 5 units is now dedicated to e-VLBI. Hence, we currently have seven Mark 5A and four Mark 5B units available for correlation.

**Software Correlator:** In order to meet the requirements of the software correlator especially concerning cooling and noise reduction, the reconstruction of the correlator room was finished in early 2009.

**DBBC:** The Bonn group is involved in the development of a DBBC for the European VLBI Network (EVN) and geodesy. The DBBC is designed as a full replacement for the existing analog BBCs. The DBBC hardware is ready except for the 10 Gbit Ethernet board which is in the prototype stage. The DBBC firmware is 80 to 90% ready. The integration of the DBBC into the Field System is currently being developed in close collaboration with Himwich/NVI-GSFC and Neidhardt/Wettzell.

## 5. Outlook for 2010

**Correlator:** We are still expecting a gradual changeover to Mark 5B, which will further simplify the correlation process since the station units will no longer be needed.

**Software Correlator:** The implementation of the phasecal signal extraction into the DiFX correlator software is expected to be finished in the very near future. Geodetic verification will be completed in 2010, followed by the changeover of geodetic correlation to the software correlator.

**e-VLBI:** Stream correlation using e-VLBI transfer will continue, and e-VLBI tests with other antennas are planned/ongoing. An additional 20 TB data raid will be installed at the cluster at the end of February to increase the storage capacity for future e-transfers, especially with regard to the envisaged higher observing rate of 512 Mbps in the course of VLBI2010 and the changeover to the DiFX correlator. In order to meet the requirements of the higher observing rate, we are planning to upgrade our Internet connection from 1 Gbps to 2 Gbps. However, the funding and technical implementation prove to be difficult.

**DBBC:** The DBBC can be ordered from HAT-Lab and will be deployed in the field in 2010.

# Haystack Observatory VLBI Correlator

*Mike Titus, Roger Cappallo, Brian Corey, Kevin Dudevair, Arthur Niell, Alan Whitney*

## Abstract

This report summarizes the activities of the Haystack Correlator during 2009. Highlights include an increase in workload, correlation of many broadband delay (VLBI2010) experiments, a digital-backend comparison test, installation of a new data server, IYA2009 preparations, Mark 5 software upgrades, and other software development projects. Non-real-time e-VLBI transfers and engineering support of other correlators continued.

## 1. Introduction

The Mark IV VLBI correlator of the MIT Haystack Observatory, located in Westford, Massachusetts, is supported by the NASA Space Geodesy Program and the National Science Foundation. The available correlator time is dedicated mainly to the pursuits of the IVS, with a small portion of time allocated to processing radio astronomy observations for the Ultra High Sensitivity VLBI (u-VLBI) project. The Haystack Correlator serves as a development system for testing new correlation modes, for e-VLBI, for hardware improvements such as the Mark 5C system, and for diagnosing correlator problems encountered at Haystack or at one of the identical correlators at the U.S. Naval Observatory and the Max Planck Institute for Radioastronomy. This flexibility is made possible by the presence on-site of the team that designed the correlator hardware and software. Additionally, some production correlator time is dedicated to processing geodetic VLBI observations for the IVS.

## 2. Summary of Activities

This year has seen a large increase in the workload at the Haystack correlator. Total correlation hours increased  $>20\%$ , and the total number of experiments processed almost doubled. The broadband delay project in particular saw over a tripling of the number of experiments correlated. The number of 24-hour geodetic sessions (R&Ds and T2s) processed also increased slightly, with several R&Ds requesting rapid turnaround. Astronomy-related projects also saw significant activity, both for the actual correlation and especially for the complex task of setting them up. A 1 mm galactic center (SgrA\*) observation project was correlated, and tests of a phased array processing system to combine the collecting area of multiple antennas at the Mauna Kea Hawaii site were an ongoing effort throughout the year. All these projects made for a very busy year. It is anticipated that the processing of the IYA2009 session, which began in December 2009, will contribute to a heavy work load in 2010 as well.

### 2.1. Broadband Delay Experiments

As mentioned above, many broadband delay development experiments using prototype VLBI2010 systems were conducted and correlated in a wide variety of configurations, including different frequency placements of the RF bands, different LO frequency offsets, and phase cal modifications of various types. These experiments were designed to explore the capabilities and potential limitations of the evolving VLBI2010 hardware. Most were interferometric observations between the

Westford 18-m and the GGAO 5-m antennas, with the post-receiver hardware at each site including four digital back ends (DBEs) and Mark 5B+ units.

These broadband delay experiments dwarfed all but the standard 24-hour geodetic projects this year, both in terms of correlator hours used and in terms of the number of experiments conducted. The early portion of the year was extensively devoted to investigation of phase cal tone corruption and a few polarization studies. Once the phase cal problem was solved, overlapping band tests, frequency offset tests, and source surveys were conducted. Overall, 34 individual broadband schedules were correlated.

## 2.2. WACO Backup Support

During the Technical Operations Workshop held at Haystack in April, the Haystack correlator was used to process four Kokee-Wettzell Intensive sessions, with the data then being sent down to WACO for export. This was done to demonstrate that Haystack could serve as a backup correlation site in the event of down time at WACO.

## 2.3. Digital Backend Testing

After the Technical Operations Workshop held at Haystack, a number of attendees stayed to conduct an intercomparison test between independently developed digital backend systems. This so-called “DBE shootout” involved the Chinese DBE system (CDAS), the EVN’s dBBC system, and the Haystack-Berkeley designed DBE1. These tests were correlated on the Haystack correlator. For the results of these tests, see: [http://web.haystack.edu/geo/vlbi\\_td/BBDev/036.html](http://web.haystack.edu/geo/vlbi_td/BBDev/036.html)

## 2.4. Bonn Correlator Support

Of the requests for help from the Bonn correlator that were fielded this year, the most notable was the diagnosis of a messaging system hang problem which prevented overnight unattended operation of the correlator. This problem was traced back to the disconnecting of all tape drives from the system without the corresponding removal of the mcb program which communicates with them. A work-around, which deletes messages to this process, has fixed the problem until the tape drive communications to mcb can be removed from the software.

## 2.5. New Server for Disk Space and Post-processing

A new server was procured and is now in use in order to provide 6 TB more disk space for correlator output, more space for software development, and an upgraded post-processing platform. This new capability was especially needed to support the IYA2009 experiment recorded in November.

## 2.6. Preparations for the IYA2009 Session

Preparations for the IYA2009 were conducted, including fringe tests to check various features needed for the Japanese K5 format stations. These included tests of a data doubling technique to accommodate stations which could not support 8 MHz channel bandwidth, Mark 5B conversion from K5 format, and testing of the IYA2009 recording mode. In a separate but somewhat related project, a Japanese VERA station (Mizusawa) was tested for inclusion in the T2 experiment series.



## 2.7. Mark 5A/5B/5C Recording System Related Projects

A feature needed in the Mark 5B/DOM correlator playback software (domino) to play back modules with bad individual disks was enabled this year. Conduant's SDK 8.2 software was incorporated into the Mark 5 software in order to address issues with handling SATA modules, and many other Mark 5 support related activities were conducted. SDK 8.2 based Mark 5A software and the Debian operating system were installed on all the Haystack correlator Mark 5A playback units in 2009.

## 2.8. Correlator Software Development

An upgrade to combine multiple correlator file roots and to fringe-fit up to 64 frequency channels simultaneously in fourfit was a major project this year. This capability is needed for the broadband project and for the 1 mm u-VLBI astronomy projects. Improvements to the correlator software build system to accommodate the growing number of machine architectures and compilers is also a major ongoing project.

## 2.9. e-VLBI

Non-real-time transfers have continued. Data from 17 experiments were transferred to Haystack this year from six stations, all in Japan: Kashima, Tsukuba, Chichijima, Shintotsukawa, Aira, and Mizusawa.

## 2.10. Experiments Correlated

In 2009, fifty-seven geodetic VLBI experiments were processed at the Haystack correlator, consisting of ten R&Ds, three T2s, and forty-four test experiments. The test experiments included broadband development and a wide assortment of other projects, some of which were mentioned in the summary above. As usual, there was also a large number of smaller tests that are not included in the above count because they were too small to warrant individual experiment numbers.

## 2.11. Current/Future Hardware and Capabilities

As of the end of 2009 functioning hardware installed at the correlator included 2 tape units, 7 Mark 5A units, 7 station units, 4 Mark 5B units (DOMs) with their associated correlator interface boards (CIBs), 16 operational correlator boards, 2 crates, and miscellaneous other support hardware. We have the capacity to process all baselines for 11 stations simultaneously in the standard geodetic modes, provided the aggregate recordings match the above hardware matrix. This is the same configuration as described in last year's report.

In 2010, we hope for an expansion of stations recording on Mark 5B units in order to more efficiently process the IYA2009 session that was recorded in November.

## 3. Staff

Staff who participated in aspects of Mark IV, Mark 5, and e-VLBI development and operations include:

### 3.1. Software Development Team

- John Ball - Mark 5A/5B; e-VLBI
- Roger Cappallo - real-time correlator software and troubleshooting; system integration; post processing; Mark 5B/5C; Linux conversion; e-VLBI
- Trevor Cappallo - post processing software
- Kevin Dudevoir - correlation; maintenance/support; Mark 5A/5B/5C; e-VLBI; Linux conversion; correlator software and build system development; computer system support/development
- Chester Ruszczyk - e-VLBI; Mark 5A/5B/5C
- Jason SooHoo - e-VLBI; Mark 5A/5B/5C
- Alan Whitney - system architecture; Mark 5A/5B/5C; e-VLBI

### 3.2. Operations Team

- Peter Bolis - correlator maintenance
- Brian Corey - experiment correlation oversight; station evaluation; technique development
- Dave Fields - playback drive maintenance; Mark 5 installation and maintenance; general technical support
- Glenn Millson - correlator operator
- Arthur Niell - technique development
- Don Sousa - correlator operator; experiment setup; tape library and shipping
- Mike Titus - correlator operations oversight; experiment setup; computer services; software and hardware testing
- Ken Wilson - correlator maintenance; playback drive maintenance; general technical support

## 4. Conclusion/Outlook

Migration of additional correlator run-time programs to the Linux platform is expected in the coming year. Expansion of the use of Mark 5B units at all correlators will continue in support of IYA2009 processing and as more field stations convert to Mark 5B. More Mark 5C testing is anticipated. Although Mark IV correlator development will continue, a concerted effort to move to a software-based correlator will occur in the coming year. Most likely this will be a variant of the Swinburne correlator originally developed by Adam Deller, similar to the ones at Bonn and the VLBA.

## IAA Correlator Center

*Igor Surkis, Artemy Fateev, Voitsekh Ken, Alexey Melnikov, Vladimir Mishin,  
Violet Shantyr, Vladimir Zimovsky*

### Abstract

The construction of the ARC (Astrometric Radiointerferometric Correlator) has been completed. ARC is a 6-station VSI-H XF-type hardware VLBI correlator.

The VLBI data of the 3-station sessions of the Russian Quasar network was processed using the ARC correlator. Mark 5B units were used for recording the VLBI data at the stations and for playback at the correlator.

### 1. Introduction

The IAA Correlator Center is located and staffed by the Institute of Applied Astronomy in Saint Petersburg, Russia.

The IAA Correlator Center is devoted to processing geodetic, astrometric, and astrophysical observations made with the Russian VLBI network Quasar.

### 2. Summary of Activities

The production of the ARC, the VLBI XF hardware correlator, has been completed in 2009.

The ARC is a 6-station, 15-baseline correlator. It is able to process up to 16 frequency channels on each baseline, for a total of 240 channels. The correlator accesses two-bit VLBI signals with a 32 MHz maximal TAC frequency. The maximal data range from each station is 1 Gbit per second. The correlator requires VSI-H input VLBI signals, and it is equipped with Mark 5B playback terminals.

The ARC hardware is based on FPGA technology. Data processing and data transfer boards are placed in the Compact PCI 6U crates. All of the ARC hardware is mounted in four racks. Figure 1 shows a photo of the correlator.

The correlator hardware control is performed with a desktop computer, which is connected to the crates via a correlator local network. The ARC software is a distributed system between the control computer and the crates. The software runs under GNU/Linux and has a GUI.

From February 2009, the ARC has been used in a minimal 2-station assembly to process observation data. In July 2009 it was expanded to a 3-station correlator. The full scale 6-station correlator was completed in October 2009. In 2010 we are planning to improve the ARC software.

### 3. Experiments Done

In the past year the IAA Correlation Center processed the national observations of the 3-station VLBI network Quasar.

In January 2009 two Ru-E and two Ru-U sessions were observed and processed at the IAA Correlation Center. The 24-hour 3-station Ru-E VLBI sessions are intended for EOP estimation. The eight-hour 2-station Ru-U VLBI sessions are intended for UT1-UTC estimation. S2 terminals were used at the sites to record one-bit sampling data from 2 MHz bandwidth VC's. The total bit



Figure 1. The 6-station ARC correlator

rate from each station was 64 Mbit/s. The scan length was 150 seconds. About 12 scans per hour were observed. These series were processed with the 12-board MicroPARSE correlator.

The Quasar network stations started recording national VLBI observations on Mark 5B units in February 2009 and the ARC was used for data processing. The VC's bandwidth for the Ru-E and the Ru-U sessions has grown up to 16 MHz and 8 MHz, respectively. One-bit sampling was used. The total bit rate was 512 Mbit/s for the Ru-E sessions and 256 Mbit/s for the Ru-U sessions. The scan lengths were 60 seconds for both the Ru-E and the Ru-U sessions. Nearly 20 scans per hour were observed. The duration of the Ru-U sessions was initially two hours; then, starting in July 2009, it was decreased to one hour. Some of the one-hour Ru-U sessions were transferred from the stations to the correlator in e-VLBI mode.

From February to December 2009, 22 Ru-E sessions and 27 Ru-U sessions were processed, and EOP and UT1-UTC were estimated.

Several experiments with the Crimea (Sm) station have been observed. Four 4-station 24-hour

sessions were observed in 2009. The 4 MHz bandwidth VC's were recorded with one-bit sampling, and the total bit rate was 128 Mbit/s. These sessions were processed at the IAA Correlation Center using the ARC correlator.

#### 4. Staff

- Igor Surkis — leading investigator, software developer;
- Artemy Fateev — software developer;
- Voitsekh Ken — hardware developer;
- Alexey Melnikov — software developer, scheduler;
- Vladimir Mishin — software developer, post processing;
- Violet Shantyr — software developer, post processing;
- Vladimir Zimovsky — hardware developer.

# VLBI Correlators in Kashima

*Mamoru Sekido, Moritaka Kimura*

## Abstract

Software correlator systems developed at the Kashima Space Research Center are used for data processing of R&D VLBI experiments. Two major correlation tasks processed in 2009 were the MARBLE project for reference baseline evaluation and the time standard comparison project. The automatic data processing scheme with distributed processing has been extensively used for these VLBI data processing. A new software correlation system, which uses the high speed software correlator 'GICO3', has been completed for the VERA project.

## 1. General Information

The VLBI group of the Kashima Space Research Center (KSRC) of the National Institute of Information and Communications Technology (NICT: Fig.1) has been contributing to the VLBI community by developing the VLBI data acquisition system (DAS) and correlation systems.

The multi-channel DAS named K5/VSSP32 [1] has been used for geodetic and radio science observations. A corresponding software correlation package for K5/VSSP32 has been developed and maintained by T. Kondo. Another DAS system named K5/VSI [2], which captures the data stream from a VSI-H interface [4], has another software correlator called 'GICO3' [3]. The two software correlators have been developed in parallel.

The former K5/VSSP32 system is a multi-channel data acquisition system with four channel inputs per unit. One unit has sampling capability in the range of 40 kHz to 64 MHz, with quantization bits 1, 2, 4, and 8 under the limitation of a maximum output data rate of 256 Mbps. The geodetic K5 DAS system is composed of four K5/VSSP32 units. This system has been widely used for geodesy operationally. e-VLBI experiments for rapid UT1 measurements have been performed with this system within a collaboration among the Onsala, Metsähovi, Tsukuba, and Kashima stations.

The K5/VSI system was originally developed as a high sampling rate DAS system for astronomy. The K5/VSI system has become compatible with the Mark 5B DAS through the joint use of the multi-channel data sampler ADS2000, which has a VSI-H interface for data output. The Kashima station participated in an e-VLBI observation demonstration at the IYA2009 opening ceremony, using this Mark 5B emulation system. Now, the K5/VSI has been employed as the software correlation system of the VERA project by NAOJ (National Astronomical Observatory of Japan).

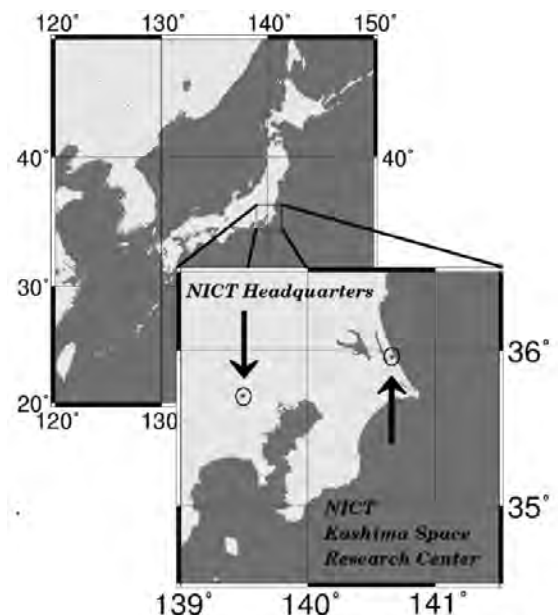

Figure 1. Location of NICT/KSRC.

## 2. Staff

The names of the staff members who contribute to the Correlation Center at NICT/Kashima and their tasks are listed below in alphabetical order.

- HASEGAWA Shingo: maintenance and troubleshooting of K5 system computers, operation of the 34-m station for IVS sessions.
- HOBIGER Thomas: developer of a new VLBI database system that uses NetCDF, research on atmospheric delay calibration with the ray tracing technique.
- ICHIKAWA Ryuichi: VLBI Project Manager at Kashima, research on the MARBLE project, atmospheric delay with ray tracing.
- KAWAI Eiji: maintenance of the 34-m telescope, operation of the 34-m station for IVS sessions.
- KIMURA Moritaka: developer of the high speed Gigabit software correlator ‘GICO3’ and the K5/VSI DAS system.
- KONDO Tetsuro: development and maintenance of the software correlator package for K5/VSSP32 (working at Ajou University in Korea since April 2008).
- KOYAMA Yasuhiro: Group Leader of “Space-Time Application Group”.
- SEKIDO Mamoru: e-VLBI development and observations, maintenance of the 34-m station.
- TSUTSUMI Masanori: maintenance of K5 system computers.

## 3. Component Description

The correlation of VLBI data was mainly performed by the K5/VSSP32 software correlator. VLBI experiments for the MARBLE project [5] and for the time standards comparison project [6] were the major focus of our correlation center in 2009. Table 1 shows a brief summary of the experiments. Ultra-rapid UT1 observations with e-VLBI technology have been performed by the Geographical Survey Institute (GSI) on the Onsala—Tsukuba baseline. We have supported these e-VLBI experiments, although actual correlation has been performed by GSI. Figure 2 shows the

Table 1. Major correlation tasks processed in 2009.

Project	Exp code	Date	Stations	baseline x scans	Data rate (Mbps)
MARBLE	mb9155	4-5 Jun.	Ts32, Ks11, Mb1	2x300	512
MARBLE	mb9176	25-26 Jun.	Ts32, Ks11, Mb1	2x300	512
MARBLE	mbc240	28-30 Aug.	Ks34, Ks11, Kg11	3x1400	256
MARBLE	mb9358	24-25 Dec.	Ts32, Ks34, Mb1, Mb2	2x240, 3x140	512
Time Comp.	k09158	7-9 Jun.	Ks34, Ks11	1x1568	256
Time Comp.	k09239	27-28 Aug.	Ks34, Ks11	1x1680	256
Time Comp.	k09351	17-19 Dec.	Ks34, Ks11	1x11160	256

Ts32:Tsukuba-32m, Ks34:Kashima-34m, Ks11:Kashima-11m, Kg11:Koganei-11m, Mb1:Marble-1, Mb2:Marble-2

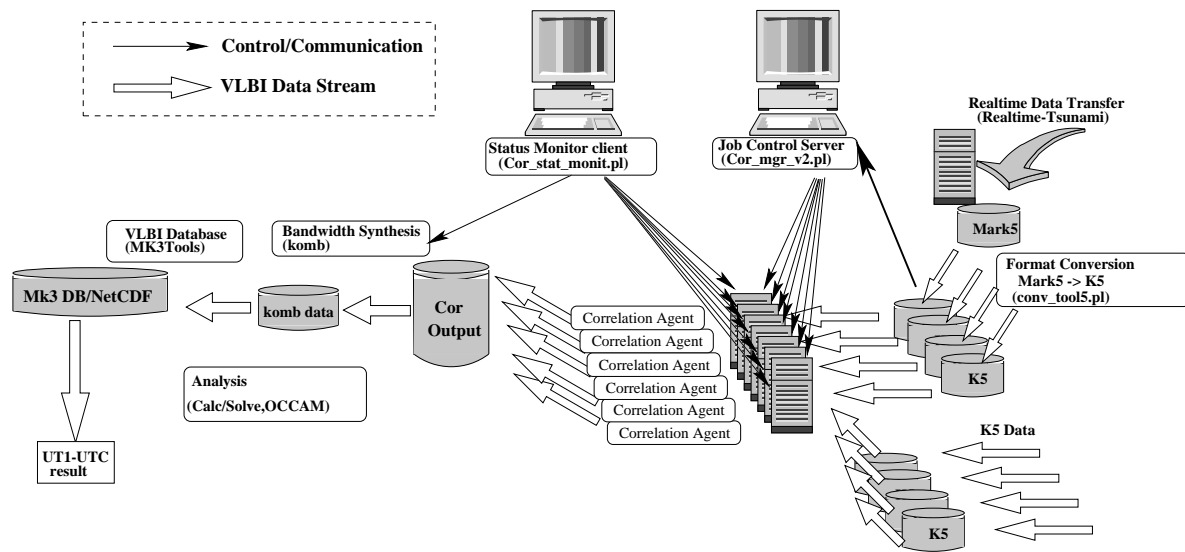

Figure 2. Distributed software correlation system with a cluster of PCs.

schematic view of the correlation data processing scheme with software correlator. A subsidiary software package for distributed correlation processing has been written in the Perl script programming language. The software modules written in Perl scripts communicate with each other, and they accomplish the distributed data processing. The data conversion (Mark IV  $\rightarrow$  K5/VSSP32) and correlation processing tasks are invoked from these scripts.

## 4. Development and Future Plans

### 4.1. e-VLBI Development

The K5/VSI DAS became compatible with the Mark 5B DAS through the joint use of the ADS2000 multi-channel sampler. A software package for real-time data stream transmission with UDP/IP was developed, and successful participation in international e-VLBI experiments organized by JIVE and ATNF was achieved. A specification of the standard VLBI data interchange format (VDIF) [7] was ratified at the e-VLBI workshop held in Madrid in 2009. By taking advantage of the VDIF for a format of UDP packet, we have developed new K5/VSI data transmission software. This new software is going to be used to speed up the UT1 measurements in Intensive sessions that use the Wettzell—Tsukuba baseline.

### 4.2. Fast Software Correlator ‘GICO3’

The high speed GICO3 correlation software has been adopted for the VERA project [8]. This correlation system has been developed with the goal of simultaneous five station, ten baseline correlation capability [9]. The maximum data rate is one Gbps per station. A fascinating characteristic of GICO3 is that the processing rate per station does not depend on the number of stations. Thus, the total processing performance is scalable by the designated number of stations. The left part of Table 2 compares the performance under the same conditions of the GICO3 software correlator and the DiFX software correlator [10], which is being widely used in the international VLBI



Table 2. Performance comparison of the GICO3 and DiFX software correlator(left) and specification of software correlation system of the VERA Project (right).

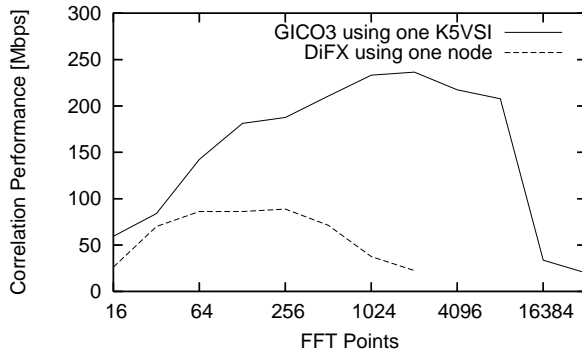

Stations	5
Baselines	10
Processing Rate	512 - 1024 Mbps/station
Lags Number	64 - 65536 points
Output	10 cross and 5 auto correlations
Output rate	1 - 100Hz
Output format	CODA, FITS

community. The plot clearly shows that GICO3 has 2-4 times higher performance than DiFX. See [3] for details on the architecture of GICO3. The software code of the GICO3 correlator will be available to the public and will become freely available from the Internet soon. The right table lists the specification parameters of VERA's software correlator, which uses GICO3. Development of the GICO software correlator for geodetic applications is in progress.

## References

- [1] T. Kondo, et al.: Development of a New VLBI Sampler Unit (K5/VSSP32) Equipped with a USB 2.0 Interface, IVS 2006 General Meeting Proceedings, edited by Dirk Behrend and Karen Baver, NASA/CP-2006-214140, p.195-199, 2006.
- [2] M. Kimura, et al.: The VLBI recording system based on VSI-H with a PC, submitted to Experimental Astronomy, 2009.
- [3] M. Kimura. et al.: High Speed VLBI Software Correlator, Submitted to Pub. Astr. Soc. Pacific, 2010.
- [4] Whitney, A. R.: VLBI Standard Hardware Interface Specification -VSI-H Rev. 1.0<sup>1</sup>, 2000.
- [5] Ichikawa, R., et al.: Present Status and Outlook of Compact VLBI System Development for Providing over 10km Baseline Calibration, IVS NICT-TDC News<sup>2</sup>, **30**, pp. 22-25, 2009.
- [6] Takiguchi, H., et al.: Comparison Study of VLBI and GPS Carrier Phase Frequency Transfer -Part II-, IVS NICT-TDC News<sup>2</sup>, **30**, pp. 26-29, 2009.
- [7] Whitney, A. R., et al.: VLBI Data Interchange Format (VDIF), Proceedings of the 8<sup>th</sup> e-VLBI workshop at Madrid, PoS(EXPReS09)042 2009.
- [8] M. Honma et al.: Multi-Epoch VERA Observations of H<sub>2</sub>O Masers in OH 43.9 - 0.1, Publ. Astron. Soc. Japan, **57**, pp. 595-603, 2005.
- [9] M. Kimura: Development of the software correlator for the VERA system, IVS NICT-TDC News<sup>2</sup>, **26**, 26-27, 2005.
- [10] Deller, A. T., et al.: DiFX: A Software Correlator for Very Long Baseline Interferometry Using Multi-processor Computing Environments, Pub. Astr. Soc. Pacific, **119**, pp. 318-336, 2007.

<sup>1</sup><http://www.vlbi.org/vsi/>

<sup>2</sup><http://www2.nict.go.jp/w/w114/stsi/ivstdc/news-index.html>

# Tsukuba VLBI Correlator

*Yuji Miura, Kensuke Kokado, Shinobu Kurihara*

## Abstract

This is a report of the activities at the Tsukuba VLBI Correlator in 2009. The Tsukuba VLBI Correlator processed 99 IVS-INT2 sessions and seven JADE sessions. It should be mentioned that the INT2 processing and analysis has been automated. We can obtain the dUT1 value within one hour at the latest after the end of INT2 sessions with the automatic processing system.

## 1. Introduction

The Tsukuba VLBI Correlator is a part of VLBI facilities operated by the Geographical Survey Institute (GSI) in Japan, as well as the Tsukuba 32-m VLBI station (TSUKUB32). The system consists of a K5/VSSP correlation software package developed by National Institute of Communications and Technology (NICT), a number of servers, and disk storage [1]. For regular correlation, we process JADE sessions, domestic geodetic 24-h VLBI sessions, and IVS-INT2 sessions that are observed on the TSUKUB32 – WETTZELL baseline the weekend.

## 2. Component Description

The specifications of the K5/VSSP correlation system components in the Tsukuba VLBI correlator are described in Table 1.

Table 1. Specifications of the K5/VSSP correlation system components

	system 1	system 2
management computer (CPU)	1 Intel Pentium 4, 3.0GHz	1 Intel Pentium 4, 3.0GHz
data servers (CPU)	12 Intel Pentium 4, 3.0GHz	6 Intel Pentium 4, 3.4GHz Intel Xeon 3.4GHz (dual CPUs)
correlation servers (CPU)	16 (rackmount type computer) Intel Xeon 3.06GHz (dual CPUs)	6 (rackmount type computer) Intel Xeon 3.4GHz (dual CPUs)
format	K5/VSSP	
media type	SATA disk cartridge	
kernel program package	ipvlbi20080930, komb20080219	
aid application	PARNASSUS 1.3, MK3TOOLS	MK3TOOLS, Cor_mgr
OS	Linux	
purpose	JADE	IVS-INT2
operation	~ April 2008	~ August 2006

All of the hardware such as servers and HDDs are commercially-based products.

As for international network connections, the Tsukuba correlator has been connected to SINET3 (Science Information NETwork 3) operated by the National Institute of Informatics (NII)

for high-speed data transfer to overseas. The UDP-based protocol “Tsunami (ver.1.1 build 36)” is used for the data transfer. TCP-based protocols such as FTP are also available. There are three servers (Intel Xeon 3.8 GHz) for the data transfer and large HDD storage (45.8 Tbyte) for storing raw VLBI data.

The K5/VSSP kernel software developed by NICT and the graphical user interface “PARNASSUS” developed by GSI are used in correlation processing [2]. PARNASSUS is also used for distributed processing in correlation. The data in Mark 5 format is processed after being converted to K5 format. A Linux server (Intel Xeon 3.8 GHz) with the CALC 10.01 & SOLVE release of 2008.07.31 and OCCAM version 6.1 installed is used for primary analysis.

### 3. Staff

Table 2 shows a list of the staff at the Tsukuba VLBI Correlator. Almost all operations have been carried out by operators from the private contractor “Advanced Engineering Service Co., Ltd (AES)”.

Table 2. Staff of the Tsukuba VLBI correlator

Name	Position
Yuji MIURA	Technical staff (management)
Kentaro NOZAWA	Technical operator (AES)
Yasuko MUKAI	Technical operator (AES)
Toshio NAKAJIMA	System engineer (Network)

## 4. Current Status and Activities

### 4.1. JADE Session Processing

JADE is a geodetic 24-h VLBI session series observed at GSI stations (TSUKUB32, SINTOTU3, CHICHI10, and AIRA) and two VERA stations (VERAMZSW and VERAISGK) operated by the National Astronomical Observatory of Japan (NAOJ). Out of these stations, only TSUKUB32 and VERAISGK are connected to the broad-band network, so data transfer via Internet is available. For the other stations, the network transfer speed is too slow to transfer raw VLBI data to the correlator, so we need data media shipping.

The JADE sessions processed at the Tsukuba correlator in 2009 are shown in Table 3.

The SINTOTU3 (3.8-m main reflector diameter) – CHICHI10/AIRA (10-m main reflector diameter) baselines had not been correlated because of the low sensitivity of the baselines that use SINTOTU3. We tried to optimize the observation schedule so that we can process these baselines in JADE-0911. As a result, fringes were detected in 79 observations on SINTOTU3 – CHICHI10 and 91 observations on SINTOTU3 – AIRA, and these observation data were used for baseline analysis.

Table 3. JADE sessions processed in 2009

Session	Stations	Processed baseline #
JADE-0901	TsAiCcVmVs	10
JADE-0903	TsAiCcVmVs	10
JADE-0905	TsAiCcS3VmVs	13
JADE-0906	TsAiCcS3Vs	7
JADE-0907	TsAiCcS3Vs	7
JADE-0908	TsAiCcS3Vm	7
JADE-0911	TsAiCcS3	6

## 4.2. IVS-INT2 Session Processing

IVS-INT2 sessions processed at the Tsukuba correlator in 2009 are shown in Table 4.

Table 4. IVS-INT2 sessions processed in 2009

Session	Stations	Processed baseline #
IVS-INT2	TSUKUB32-WETTZELL	97
IVS-INT2	KASHIM34-WETTZELL	2

In IVS-INT2 processing, almost all processes are automated, including the data transfer from the stations, the data conversion from Mark 5 to K5 format, correlation, and analysis (Figure 1) [3].

By automated processing and analysis, the dUT1 result is calculated within one hour at the latest after the last scan. CALC/SOLVE had been used for a long time for our primary analysis. However, as it is not adequate to automate VLBI analysis, we utilized OCCAM for this. The Mark III database is submitted to an IVS Data Center after being checked by the operator.

Figure 2 shows the IVS-INT2 dUT1 time series with respect to IERS EOPC04 during 2009. The standard deviation of estimated dUT1 is around 5 – 15  $\mu$ sec.

## 4.3. Ultra Rapid DUT1 Experiments

Following last year's results we have continued the Ultra-rapid dUT1 experiments based on a joint project of Japan (GSI & NICT) and Fennoscandia (Onsala & Metsähovi). The description of the experiments is reported in "Tsukuba 32-m VLBI Stations" in the Network Stations section of this volume.

## 5. Plans in 2010

In 2010, the Tsukuba correlator will continue to process JADE & IVS-INT2 sessions. Nine JADE sessions and 102 IVS-INT2 sessions are scheduled.

### The automatic processing for INT2 session

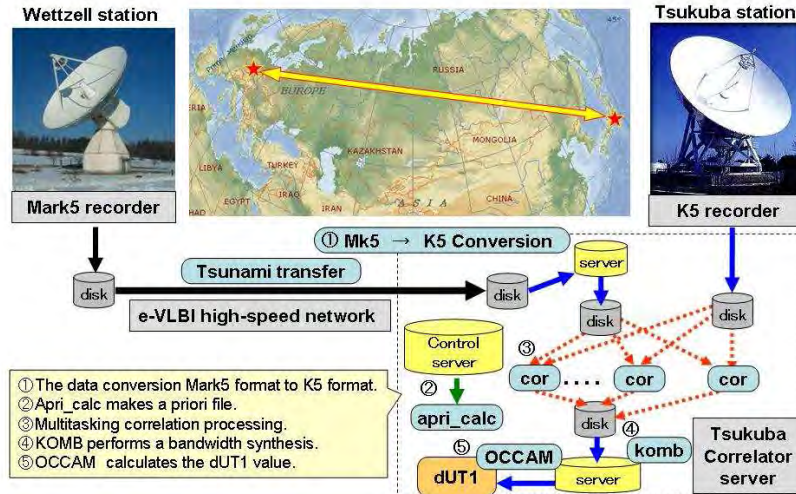

Figure 1. The automatic processing for INT2 sessions

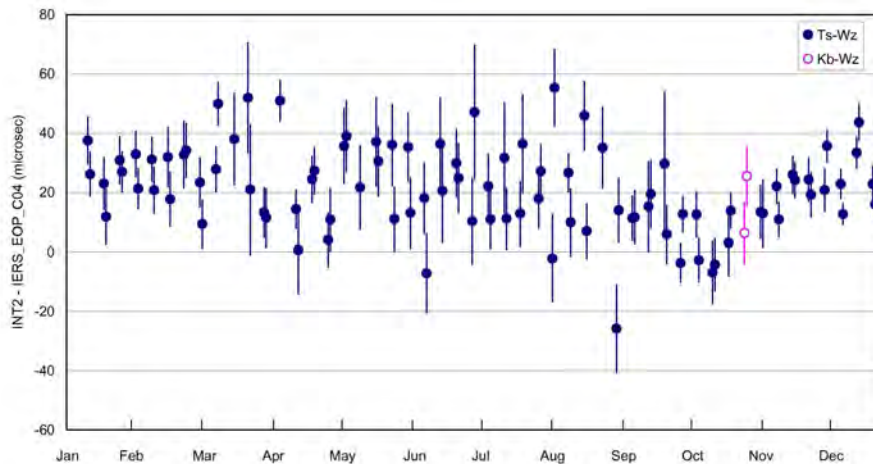

Figure 2. UT1-UTC time series w.r.t. IERS EOPC04

### References

- [1] T. Kondo: K5/VSSP VLBI SYSTEM, <http://www2.nict.go.jp/w/w114/stsi/K5/VSSP/index-e.html>.
- [2] M. Machida, M. Ishimoto, K. Takashima, T. Kondo, Y. Koyama: K5/VSSP Data Processing System of Small Cluster Computing at Tsukuba VLBI Correlator, IVS 2006 General Meeting Proceedings, edited by D. Behrend and K. Baver, NASA/CP-2006-214140, 117-126, 2006.
- [3] K. Nozawa, H. Shigematsu, K. Kokado and S. Kurihara: Data processing and analysis tools for ultra-rapid UT1 measurement, IVS NICT Technology Development Center News, No. 30, 33-35, 2009.

# Washington Correlator

*Kerry A. Kingham, David M. Hall*

## Abstract

This report summarizes the activities of the Washington Correlator for the year 2009. The Washington Correlator provides up to 80 hours of attended processing per week plus up to 50 hours of unattended operation, primarily supporting Earth Orientation and astrometric observations. In 2009 the major programs supported include the IVS-R4, IVS-INT, CONT08, APSG, and CRF observing sessions.

## 1. Introduction

The Washington Correlator (WACO) is located at and staffed by the U. S. Naval Observatory (USNO) in Washington, DC, USA. The correlator is sponsored and funded by the National Earth Orientation Service (NEOS) which is a joint effort of the USNO and NASA. Dedicated to processing geodetic and astrometric VLBI observations, the facility spent 100 percent of its time on these sessions. All of the weekly IVS-R4 sessions, all of the IVS-INT01 Intensives, the APSG and CRF sessions and the entire CONT08 were processed at WACO. The facility houses a Mark IV Correlator.

## 2. Correlator Operations

- The Washington Correlator continues to operate 80 hours per week with an operator on duty. The correlator has continued to function well unattended, allowing another 40 hours per week, on average, of extra processing. This has also decreased the time it takes to process an R4 or a T2 by one day, and it has allowed more rapid processing of CONT08 sessions.
- The CONT08 session (15 days of continuous observations) was completed in 2009. 12 CONT08 days were processed in 2008 and 3 were completed in 2009, with the entire clean dataset exported at the end of January.
- The correlator staff continues the testing and repair of Mark 5 modules. Not only were failed disks replaced, but some modules were upgraded by the replacement of lower capacity disks with higher capacity disks.
- Prior to June, 2009, Intensive observations from Wettzell were electronically transferred to the Washington area and transported to the correlator. After June 5, 2009, observations from Wettzell were sent directly to the correlator over an Internet 2 connection. This operation saves 1 to 2 days of shipping time.
- A Mark 5B playback unit was added to the correlator complement of Mark 5's, which now allows the correlator to process 11 stations (8 Mark 5A and 3 Mark 5B) simultaneously. In addition, a Mark 5B+ was acquired and is being used to support the data transfers from Wettzell.
- Table 1 lists the experiments processed during 2009.



Figure 1. A view of the Mark IV Correlator. From right, station units, Mark 5B rack, legacy tape drive and central processing unit. More legacy tape drives are beyond the central unit. The Mark 5B+ in the background is used for e-VLBI transfers.

Table 1. Experiments processed during 2009

51	IVS-R4 experiments
2	CRF (Celestial Reference Frame)
1	T2 (Terrestrial Reference Frame)
3	CONT08
208	Intensives
20	Kk-Sv-Wz Intensives

### 3. Staff

The Washington Correlator is under the management and scientific direction of the Earth Orientation Department of the U.S. Naval Observatory. USNO personnel continue to be responsible

for overseeing scheduling and processing. During the period covered by this report, a private contractor, NVI, Inc., supplied a contract manager and correlator operators.



Figure 2. Harvis Macon keeps an eye on an R4 during processing at the WACO Mark IV Correlator.

Table 2 lists staff and their duties.

Table 2. Staff

Staff	Duties
Dr. Kerry Kingham (USNO)	Head VLBI Operations Division and Correlator Project Scientist
David Hall (USNO)	VLBI Correlator Project Manager
Bruce Thornton (NVI)	Operations Manager
Harvis Macon (NVI)	Lead Correlator Operator
Roxanne Inniss (NVI)	Media Librarian
Kenneth Potts (NVI)	Correlator Operator

#### 4. Outlook

The Washington Correlator plans to upgrade the Mark 5A playbacks to Mark 5B, in coordination with the installation of Mark 5B at the Network Stations. It is expected that the number of playbacks available will increase to 13 (8 Mark 5A and 5 Mark 5B) with the addition of 2 Mark 5B+ before the existing Mark 5A units are converted to Mark 5B.





**Data Centers**

**Data Centers**



# BKG Data Center

*Volkmar Thorandt, Reiner Wojdziak*

## Abstract

This report summarizes the activities and background information of the IVS Data Center for the year 2009. Included are information about functions, structure, technical equipment, and staff members of the BKG Data Center.

## 1. BKG Data Center Functions

The BKG (Federal Agency for Cartography and Geodesy) Data Center is one of the three IVS Primary Data Centers. It archives all VLBI related data of IVS components and provides public access for the community. The BKG Data Center is connected to the OPAR and GSFC CDDIS Data Centers by mirroring the OPAR and the CDDIS file stocks several times per day. The following sketch shows the principle of mirroring:



Figure 1. Principle of mirroring

IVS components can choose one of these Data Centers to put their data into the IVS network by using its incoming area, which each of them has at its disposal. The BKG incoming area is protected, and users need to obtain username and password to get access. (Please contact the Data Center staff.)

An incoming script is watching the incoming area and checking the syntax of the files sent by IVS components. If it is o.k., the script moves the files into the data center directories. Otherwise the files will be sent to a badfile area. Furthermore, the incoming script informs the responsible staff at the Data Center by sending e-mails about its activities. The incoming script is part of the technological unit which is responsible for managing the IVS and the Operational Data Center, and for carrying out the first analysis steps in an automatic manner. All activities are monitored to guarantee data consistency and to control all analysis steps from data arrival to delivering of analysis products to IVS.

Public access to the BKG Data Center is available through FTP and HTTP:

FTP: `ftp://ivs.bkg.bund.de/pub/vlbi/`

HTTP: `http://ivs.bkg.bund.de/vlbi/`

Structure of BKG IVS Data Center:

```
vlbi/           : root directory
ivs-special/   : special CRF investigations
ivscontrol/    : controlfiles for the data center
ivsdata/       : VLBI observation files
ivsdocuments/  : IVS documents
ivs-iers/      : old IERS solutions
ivsproducts/   : analysis products
  crf/         : celestial frames
  trf/         : terrestrial frames
  eops/        : earth orientation (24h sessions)
  eopi/        : earth orientation (Intensive sessions)
  daily_sinex/ : daily sinex files (24h sessions)
  int_sinex/   : daily sinex files (Intensive sessions)
  trop/       : troposphere
```

## 2. Technical Equipment

DELL Server (SUSE Linux Enterprise 9.5 operating system)  
disk space: 500 GBytes (Raid system)  
backup: automatic tape library

## 3. Staff Members

Volkmar Thorandt (coordination, data analysis, data center, volkmar.thorandt@bkg.bund.de)  
Reiner Wojdziak (data center, Web design, reiner.wojdzia@bkg.bund.de)  
Dieter Ullrich (data analysis, data center, dieter.ullrich@bkg.bund.de)  
Gerald Engelhardt (data analysis, gerald.engelhardt@bkg.bund.de)

# CDDIS Data Center Summary for the IVS 2009 Annual Report

*Carey Noll*

## Abstract

This report summarizes activities during the year 2009 and future plans of the Crustal Dynamics Data Information System (CDDIS) with respect to the International VLBI Service for Geodesy and Astrometry (IVS). Included in this report are background information about the CDDIS, the computer architecture, staff supporting the system, archive contents, and future plans for the CDDIS within the IVS.

## 1. Introduction

The Crustal Dynamics Data Information System (CDDIS) has supported the archiving and distribution of Very Long Baseline Interferometry (VLBI) data since its inception in 1982. The CDDIS is a central facility providing users access to data and derived products to facilitate scientific investigation. The CDDIS archive of GNSS (GPS and GLONASS), laser ranging, VLBI, and DORIS data are stored on-line for remote access. Information about the system is available via the Web at the URL <http://cddis.gsfc.nasa.gov>. In addition to the IVS, the CDDIS actively supports other IAG services including the International GNSS Service (IGS), the International Laser Ranging Service (ILRS), the International DORIS Service (IDS), the International Earth Rotation and Reference Frame Service (IERS), and the Global Geodetic Observing System (GGOS) of the IAG. The current and future plans for the system's support of the IVS are discussed below.

## 2. System Description

The CDDIS archive of VLBI data and products is accessible to the public through anonymous ftp.

### 2.1. Computer Architecture

The CDDIS is operational on a dedicated server, [cddis.gsfc.nasa.gov](http://cddis.gsfc.nasa.gov). The system has over 6 Tbytes of on-line disk storage; over 1.3 Tbytes are devoted to VLBI activities. (This total includes over 1 Tbytes devoted to raw correlator output files.) The CDDIS is located at NASA GSFC and is accessible to users 24 hours per day, seven days per week.

### 2.2. Staffing

Currently, a staff consisting of one NASA civil service employee and two contractor employees supports all CDDIS activities (see Table 1 below).

## 3. Archive Content

The CDDIS has supported GSFC VLBI coordination and analysis activities for the past several years through an on-line archive of schedule files, experiment logs, and data bases in several formats. This archive has been expanded for the IVS archiving requirements.

Table 1. CDDIS Staff

Name	Position
Ms. Carey Noll	CDDIS Manager
Dr. Maurice Dube	Head, CDDIS contractor staff and senior programmer
Ms. Ruth Labelle	Programmer

The IVS data center content and structure is shown in Table 2 below. (A figure illustrating the flow of information, data, and products between the various IVS components was presented in the CDDIS submission to the IVS 2000 Annual Report.) In brief, an incoming data area has been established on the CDDIS host computer, `cddis.gsfc.nasa.gov`. Using specified file names, operation and analysis centers deposit data files and analyzed results to appropriate directories within this filesystem. Automated archiving routines, developed by GSFC VLBI staff, peruse the directories and move any new data to the appropriate public disk area. These routines migrate the data based on the file name to the appropriate directory as described in Table 2. Index files in the main sub-directories under `ftp://cddis.gsfc.nasa.gov/pub/vlbi` are updated to reflect data archived in the filesystem. Furthermore, mirroring software has been installed on the CDDIS host computer, as well as all other IVS data centers, to facilitate equalization of data and product holdings among these data centers. At this time, mirroring is performed between the IVS data centers located at the CDDIS, the Bundesamt für Kartographie und Geodäsie in Leipzig, and the Observatoire de Paris.

The public filesystem in Table 2 on the CDDIS computer, accessible via anonymous ftp, consists of a data area, which includes auxiliary files (e.g., experiment schedule information, session logs, etc.) and VLBI data (in both data base and NGS card image formats). A products disk area has also been established to house analysis products from the individual IVS analysis centers as well as the official combined IVS products. A documents disk area contains format, software, and other descriptive files.

#### 4. Data Access

During 2009, over 250 user organizations (from over 575 distinct hosts) accessed the CDDIS on a regular basis to retrieve VLBI related files. These users successfully downloaded over 130 Gbytes of data and products (340K files) from the CDDIS VLBI archive last year.

#### 5. Future Plans

The CDDIS staff will continue to work closely with the IVS Coordinating Center staff to ensure that our system is an active and successful participant in the IVS archiving effort. Over the last two years, we have procured new computer hardware that will increase the CDDIS on-line disk storage capacity, ensure system redundancy, and better serve our user community. We will make this new system operational in the spring of 2010. New user access information will be distributed to groups who provide data and products to the CDDIS VLBI portion of the archive.

Table 2. IVS Data and Product Directory Structure

Directory	Description
Data Directories	
vlbi/ivsdata/db/ <i>yyyy</i>	VLBI data base files for year <i>yyyy</i>
vlbi/ivsdata/ngs/ <i>yyyy</i>	VLBI data files in NGS card image format for year <i>yyyy</i>
vlbi/ivsdata/aux/ <i>yyyy/ssssss</i>	Auxiliary files for year <i>yyyy</i> and session <i>ssssss</i> ; these files include: log files, wx files, cable files, schedule files, correlator notes
vlbi/raw	Raw VLBI data
Product Directories	
vlbi/ivsproducts/crf	CRF solutions
vlbi/ivsproducts/eopi	EOP-I solutions
vlbi/ivsproducts/eops	EOP-S solutions
vlbi/ivsproducts/daily_sinex	Daily SINEX solutions
vlbi/ivsproducts/int_sinex	Intensive SINEX solutions
vlbi/ivsproducts/trf	TRF solutions
vlbi/ivsproducts/trop	Troposphere solutions
Project Directories	
vlbi/ivs-iers	IVS contributions to the IERS
vlbi/ivs-pilot2000	IVS Analysis Center pilot project (2000)
vlbi/ivs-pilot2001	IVS Analysis Center pilot project (2001)
vlbi/ivs-pilotbl	IVS Analysis Center pilot project (baseline)
vlbi/ivs-pilottro	IVS Analysis Center pilot project (troposphere)
vlbi/ivs-special	IVS special analysis solutions
Other Directories	
vlbi/ivscontrol	IVS control files (master schedule, etc.)
vlbi/ivsdocuments	IVS document files (solution descriptions, etc.)
vlbi/dserver	dserver software and incoming files

# Italy INAF Data Center Report

*M. Negusini, P. Sarti, C. Abbondanza*

## Abstract

This report summarizes the activities of the Italian INAF VLBI Data Center. Our Data Center is located in Bologna, Italy and belongs to the Institute of Radioastronomy, which is part of the National Institute of Astrophysics. We also report some changes to the hardware facilities devoted to IVS activities.

## 1. Introduction

The main analysis activity and storage is concentrated in Bologna, where we store and analyze single databases, using CALC/SOLVE software.

The IRA started to store geodetic VLBI databases in 1989, but the databases archived in Bologna mostly contain data including European antennas from 1987 onward. In particular most of the databases available here have VLBI data with at least three European stations. However we also store all the databases with the Ny-Ålesund antenna observations. In 2002 we decided to store the complete set of databases available on the IVS data centers, although we limited the time span to the observations performed from 1999 onwards. All the databases have been processed and saved with the best selection of parameters for the final arc solutions. In order to perform global solutions, we have computed and stored the superfiles for all the databases.

In some cases we have introduced GPS-derived wet delays into the European databases (1998 and 1999 EUROPE experiments, for the time being), as if they were produced by a WVR. These databases are available and stored with a different code from the original databases. In order to produce these databases, we have modified DBCAL, and this new version is available to external users.

## 2. Computer Availability and Routing Access

To date, the main computer is a Linux workstation, on which Mark 5 Calc/Solve version 10 was installed and to which all VLBI data analysis was migrated. The Internet address of this computer is sarip.ira.inaf.it. Since 2007 a new server with a storage capacity of 1 TB has been available, and, therefore, all experiments performed in the previous years were downloaded and archived, thus completing the catalog. The older experiments will be analyzed in order to perform global long term analysis. At present, the databases are stored in the following directories:

- 1 = /data2/dbase2
- 2 = /geo1/dbase1
- 3 = /geo1/dbase
- 4 = /geo1/dbase3

The superfiles are stored in:

/data1/super1

The list of superfiles is stored in the file /data2/mk5/save\_files/SUPCAT. The username for accessing the databases is geo. The password may be requested by sending an e-mail to negusini@ira.inaf.it.



# Data Center at NICT

*Ryuichi Ichikawa, Hiroshi Takiguchi, Mamoru Sekido, Yasuhiro Koyama*

## Abstract

The Data Center at the National Institute of Information and Communications Technology (NICT) archives and releases the databases and analysis results processed at the Correlation Center and the Analysis Center at NICT. Regular VLBI sessions with the Key Stone Project VLBI Network were the primary objects of the Data Center. These regular sessions continued until the end of November 2001. In addition to the Key Stone Project VLBI sessions, NICT has been conducting geodetic VLBI sessions for various purposes, and these data are also archived and released by the Data Center.

## 1. Introduction

In April 2004, the Communications Research Laboratory was integrated with the Telecommunications Advanced Organization of Japan (TAO) to establish the National Institute of Information and Communications Technology (NICT) as a new institute. The IVS Data Center at NICT archives and releases the databases and analysis results processed by the Correlation Center and the Analysis Center at NICT. Major parts of the data are from the Key Stone Project (KSP) VLBI sessions [1], but other regional and international VLBI sessions conducted by NICT are also archived and released. Since routine observations of the KSP network terminated at the end of November 2001, there have been no additional data from the KSP regular sessions since 2002. In 2009, a series of geodetic VLBI sessions were carried out by using the Kashima 34 m, Kashima 11 m, and Koganei 11 m stations to demonstrate precise time comparison. Another series of astronomical VLBI sessions were carried out between the Kashima 34 m and Koganei 11 m stations to monitor the flux densities of radio variable stars using real-time e-VLBI data transfer and processing. In addition, three geodetic experiments using the compact VLBI system with a 1.6 m antenna were also carried out [2]. The analysis results in the SINEX (Solution INdependent EXchange) file format as well as other formats are available on the WWW server. Database files generated with the Mark III database file format are available upon request and will be sent to the users on DDS tape cartridges. Database files of non-KSP sessions, i.e. other domestic and international geodetic VLBI sessions, are also available on the WWW server. Table 1 lists the WWW server locations maintained by the Data Center at NICT. In the past, an FTP server was used to provide data files, but it was decided to terminate the FTP service because of the security risks of maintaining an anonymous FTP server. Instead, the `www3.nict.go.jp` WWW server was prepared to place large size data files.

The responsibilities for the maintenance of these server machines were moved from the VLBI research group of NICT to the common division for the institutional network service of the laboratory in 2001 to improve the network security of these systems.

## 2. Data Products

### 2.1. KSP VLBI Sessions

The KSP VLBI sessions were performed with four KSP IVS Network Stations at Kashima, Koganei, Miura, and Tateyama on a daily or bi-daily basis until May 1999. The high-speed ATM

Table 1. URL of the WWW server systems.

Service	URL
KSP WWW pages	<a href="http://ksp.nict.go.jp/">http://ksp.nict.go.jp/</a>
IVS WWW mirror pages	<a href="http://ivs.nict.go.jp/mirror/">http://ivs.nict.go.jp/mirror/</a>
Database files	<a href="http://www3.nict.go.jp/w/w114/stsi/database/">http://www3.nict.go.jp/w/w114/stsi/database/</a>
e-VLBI Sessions	<a href="http://www.nict.go.jp/w/w114/stsi/research/e-VLBI/UT1/">http://www.nict.go.jp/w/w114/stsi/research/e-VLBI/UT1/</a>
Hayabusa Sessions	<a href="http://www.nict.go.jp/w/w114/stsi/research/Navi/HAYABUSA/">http://www.nict.go.jp/w/w114/stsi/research/Navi/HAYABUSA/</a>

(Asynchronous Transfer Mode) network line to the Miura station became unavailable in May 1999, and real-time VLBI observations with the Miura station became impossible. Thereafter, the real-time VLBI sessions were performed with the three other stations. Once every six days (every third session), the observed data were recorded to the K4 data recorders at three stations, and the Miura station participated in the sessions with the tape-based VLBI technique. In this case, the observed data at the three stations other than the Miura station were processed in real-time, and the analysis results were released promptly after the observations completed. A day later, the observed tapes were transported from the Kashima, Miura, and Tateyama stations to the Koganei station for tape-based correlation processing of the full six baselines. After the tape-based correlation processing was completed, the data set produced with the real-time VLBI data processing was replaced by the new data set.

In July 2000, unusual site motion of the Tateyama station was detected from the KSP VLBI data series, and the frequency of the sessions was increased from bi-daily to daily on July 22, 2000. The daily sessions were continued until November 11, 2000, and the site motions of the Tateyama and Miura stations were monitored in detail. During the period, it was found that Tateyama station moved about 5 cm to the northeast direction. The Miura station also moved about 3 cm to the north. The unusual site motions of these two stations gradually settled, and the current site velocities seem to be almost the same as the site velocities before June 2000. By investigating the time series of the site positions, the unusual site motion started sometime between the end of June 2000 and the beginning of July 2000. At the same time, volcanic and seismic activities near the Miyakejima and Kozushima Islands began. These activities are believed to have caused the regional crustal deformation in the area, explaining the unusual site motions at Tateyama and Miura.

## 2.2. Other VLBI Sessions

In addition to the KSP regular VLBI sessions, domestic and international geodetic and astronomical VLBI sessions were conducted by NICT in cooperation with the Geographical Survey Institute (GSI), the National Astronomical Observatory (NAO), and other organizations. These sessions are listed in Table 2. The observed data of these sessions were correlated by using the K4 correlator and the K5 software correlator at NICT either at Koganei or at Kashima or by using a real-time hardware correlator developed by NAO.

Ultra rapid e-VLBI sessions were performed based on the proposal submitted to and approved by the IVS Observing Program Committee in May 2007. The purpose of these sessions is to

Table 2. Geodetic VLBI sessions conducted by NICT (since 2005)

Year	exp. names	sessions
2005	Geodetic	c0505 (CONT05, partial participation), GEX13
	Hayabusa	14 sessions
2006	Geodetic	GEX14, viepr2, CARAVAN (3 sessions)
	Spacecraft	Geotail : 1 session
	Pulsar	1 session
2007	Ultra Rapid e-VLBI	15 times, 29 sessions
	Time Transfer	4 sessions, 12 days in total
	Cs-Gass-Cell	1 session
	Spacecraft	Hayabusa : 1 session
2008	Ultra Rapid e-VLBI	8 times, 33 sessions
	Time Transfer	26 sessions
	Variable Star e-VLBI	31 sessions
2009	e-VLBI	15 sessions, 90.5 hours in total
	IVS	12 sessions, 332 hours in total
	Time Transfer	9 sessions, 72 hours in total
	VERA	16 sessions, 149 hours in total
	Survey	26 sessions, 276 hours in total

demonstrate e-VLBI capabilities for ultra-rapid data processing after Intensive type short period (typically one hour) observing schedules. Observed data at one site are transferred to the other site in real-time by using high speed research networks, and the format conversion and data correlation processing are done immediately after the real-time file transfer. Thus, it is expected that the database will be provided with a minimum time of latency after each session. Two stations in Japan, Tsukuba, and Kashima, and two stations in Europe, Onsala, and Metsähovi, are the regularly participating stations, and the Wettzell station will participate whenever the regular IVS Intensive session (INT2) is used for the project. Under the project, we are developing the necessary software programs to realize real-time and near real-time data processing and automated data analysis. Our goal is to release the database file on the data center's WWW server as soon as possible, as well as to release the analyzed results to the general community by using e-mail. At the end of fiscal year 2008, a software package for the ultra rapid e-VLBI was implemented in the Tsukuba stations, and GSI has routinely used it for their INT2 sessions since then. In 2009, about 20 geodetic VLBI sessions (350 hours in total) including IVS campaigns and MARBLE experiments were performed. In addition, 15 e-VLBI sessions including the IYA2009 (International Year of Astronomy 2009) session, VLBI time transfer sessions, and astronomical survey experiments were also performed. In 2009, 15 e-VLBI sessions including the IYA2009 (International Year of Astronomy 2009) session were also performed in collaboration with JIVE.

In addition, nine time transfer sessions were also performed in 2009. The purpose of the sessions is to evaluate the capability of geodetic VLBI experiments for precise and accurate time transfer between Time and Frequency Laboratories located worldwide. A series of astronomical observations (276 hours in total) were also performed to monitor flux density of radio variable

stars.

### 3. Staff Members

The data center at NICT is operated and maintained by the Space-Time Standards Group at the Kashima Space Research Center, NICT. The staff members are listed in Table 3.

Table 3. Staff members of the Space-Time Standards Group, KSRC, NICT

Name	Main Responsibilities
KOYAMA Yasuhiro	Administration of Data Servers
ICHIKAWA Ryuichi	Development of compact VLBI system
SEKIDO Mamoru	Responsible for e-VLBI sessions
TAKIGUCHI Hiroshi	Time Transfer
HASEGAWA Shingo	System Engineer

### 4. Future Plans

Although the regular VLBI sessions with the KSP VLBI network finished in 2001, the IVS Data Center at NICT will continue its service and will archive and release the analysis results accumulated by the Correlation Center and the Analysis Center at NICT. In addition, a number of VLBI sessions will be conducted for the purposes of various technology developments.

### References

- [1] Special issue for the Key Stone Project, J. Commun. Res. Lab., Vol. 46, No. 1, March 1999.
- [2] Takefuji K., Ichikawa R., and Sekido M., Technology Development Center at NICT, *IVS 2009 Annual Report*, this volume, 2010.
- [3] Koyama, Y., T. Kondo, M. Kimura, and H. Takeuchi, IVS NICT TDC News, No. 26, Sep. 2005, pp. 9-12.

# Paris Observatory (OPAR) Data Center

*Christophe Barache*

## Abstract

This report summarizes the OPAR Data Center activities in 2009. Included is information about functions, architecture, status, future plans and staff members of OPAR Data Center.

## 1. OPAR Data Center Functions

The Paris Observatory (OPAR) has provided a Data Center for the International VLBI Service for Geodesy and Astrometry (IVS) since 1999. The OPAR as well as CDDIS and BKG is one of the three IVS Primary Data Centers. Their activities are done in close collaboration for collecting files (data and analysis files) and making them available to the community as soon as they are submitted.

The three Data Centers have a common protocol and each of them:

- has the same directory structure (with the same control file),
- has the same script,
- is able to receive all IVS files (auxiliary, database, products, documents),
- mirrors the other ones every three hours,
- gives free FTP access to the files.

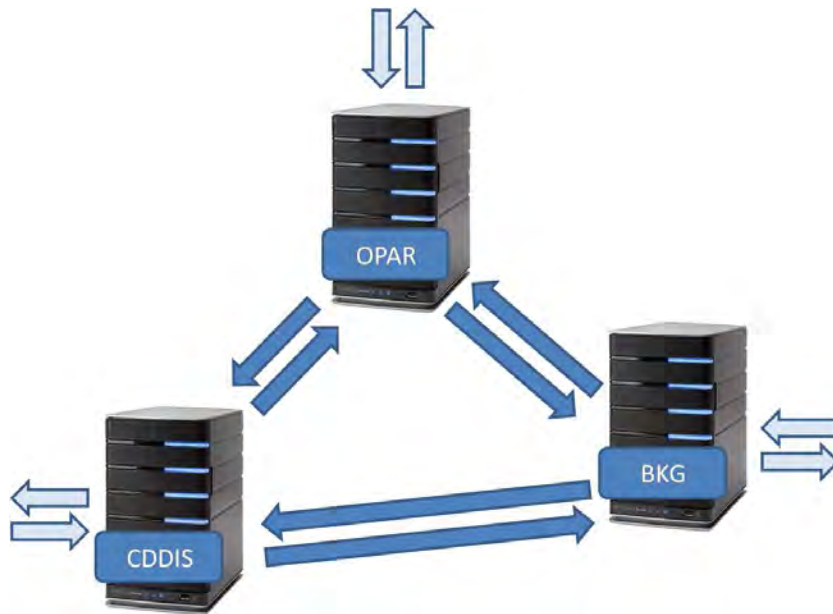

Figure 1. Mirroring among the primary Data Centers.

This protocol gives the IVS community a transparent access to a Data Center through the same directory, and a permanent access to files in case of a Data Center breakdown.

## 2. Architecture

To be able to put a file in a Data Center, Operational and Analysis Centers have to be registered by the IVS Coordinating Center. The file names have to conform to the naming conventions. A script checks the file and puts it in the right directory. The total number of failures for OPAR Data Center submissions is fewer than 10 per year; half were files uploaded by mistake, and the others were file naming errors. The script undergoes continued improvement and takes into account the IVS components' requests.

The structure of the IVS Data Centers is:

```

ivscontrol/      : provides the control files needed by the Data Center
                  (session code, station code, solution code...)
ivscontrol_new/ : temporary test directory
ivscontrol_old/ : temporary test directory
ivsdocuments/   : provides documents and descriptions about IVS products
ivsdata/        : provides files related to the observations:
  aux/          : auxiliary files (schedule, log...)
  db/           : observation files in data-base CALC format
  ngs/          : observation files in NGS format
  sinex/        : observation files in SINEX format
ivsproducts/    : provides results from Analysis Centers:
  eopi/         : Earth Orientation Parameters, intensive sessions
  eops/         : Earth Orientation Parameters, 24h sessions
  crf/          : Celestial Reference Frame
  trf/          : Terrestrial Reference Frame
  daily_sinex/  : Time series solutions in SINEX format of Earth
                  orientation and site positions
  int_sinex/    : Daily Intensive solution in SINEX format, mainly
                  designed for combination
  trop/         : Tropospheric time series (starting July 2003)
ivs-iers/       : provides products for IERS Annual Report
ivs-pilot2000/  : provides products of 2000 for special investigations
ivs-pilot2001/  : provides products of 2001 for special investigations
ivs-pilottro/   : provides tropospheric time series for Pilot Project
                  (until June 2003)
ivs-pilotbl/    : provides baselines files
ivs-special/    : specific studies
raw/            : original data (not writable at OPAR Data Center)

```

### 3. Current Status

The OPAR Data Center is operated on a PC Server (PowerEdge 2800 - Xeron 3.0 GHz) located at the Paris Observatory and running the Fedora Linux operating system.

To make all IVS products available on-line, the disk storage capacity was significantly increased, and the server is equipped now with a RAID 3 TB disk extensible up to 4.7 TB.

The OPAR server is accessible 24 hours per day, seven days per week through Internet connection with 2 Mbit/s rate. Users can get the IVS products by using the FTP protocol. Access to this server is free for users.

FTP access:

```
ivsopar.obspm.fr
username : anonymous
password : your e-mail
cd vlbi (IVS directory)
```

This year, 13 different users regularly put data on the OPAR ivsincoming FTP area.

There were also 2,417 different users of the OPAR Web server. We provide more statistical information on OPAR Data Center access in Figure 2.

### 4. Future Plans

The OPAR staff will continue to work with the IVS community and in close collaboration with the two other primary Data Centers in order to provide public access to all VLBI related data.

### 5. Staff Members

Staff members who are contributing to the OPAR Data Center and Analysis Center for IVS are listed below:

- Christophe Barache, Data Center manager and Data Analysis.
- Anne-Marie Gontier, responsible for GLORIA Analysis Software.
- Sébastien Lambert, scientific developments.
- Daniel Gambis, interface with IERS activities.

To obtain information about the OPAR Data Center please contact: [ivs.opa@obspm.fr](mailto:ivs.opa@obspm.fr)

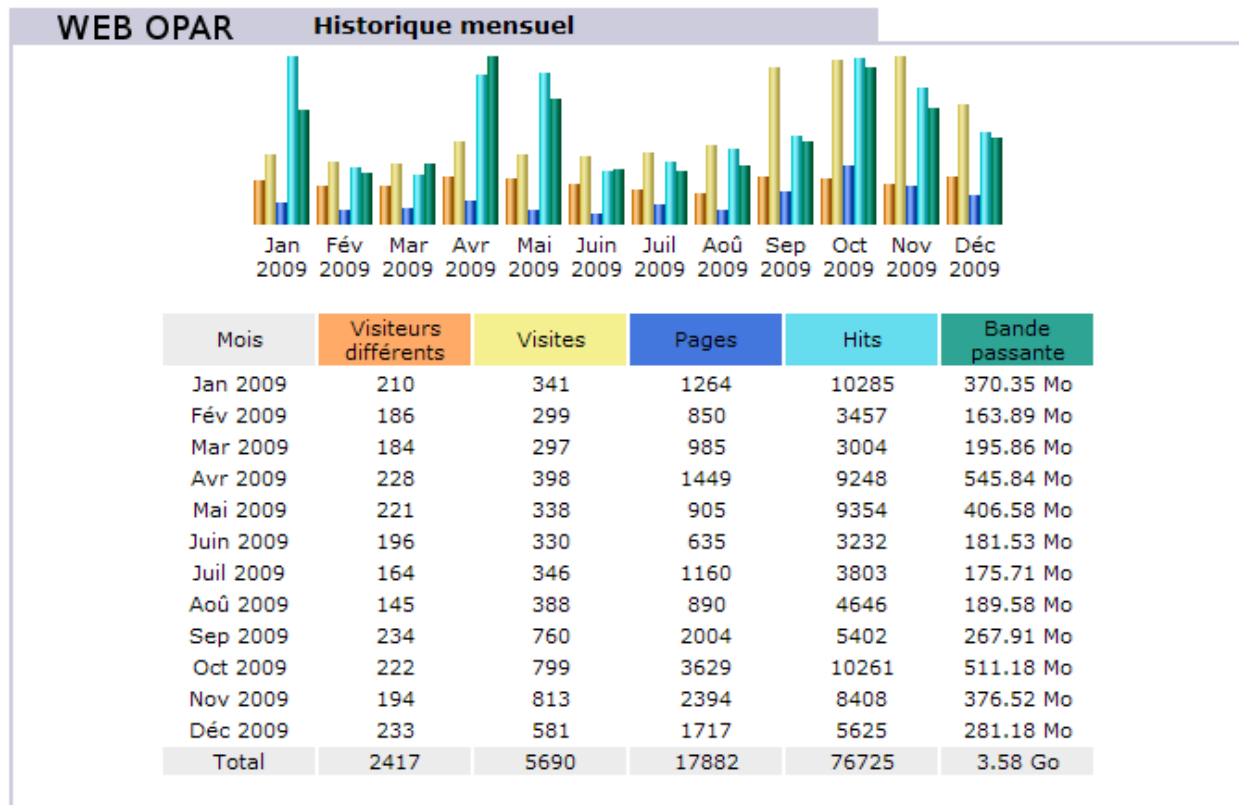

Figure 2. Monthly access of the Data Center during 2009. For each month in column 1, columns 2 through 6 show, in order, the number of different visitors, the total number of visits, the number of pages viewed, the number of accesses of the Web site, and the downloaded bandwidth in megabytes (Mo) or gigabytes (Go).





**Analysis Centers**

**Analysis Centers**



# Analysis Center of Saint Petersburg University

*Dmitriy Trofimov, Veniamin Vityazev*

## Abstract

This report briefly summarizes the activities of the Analysis Center of Saint Petersburg University during 2009. Changes that happened, as well as our future plans, are described.

## 1. Introduction

The Analysis Center of Saint Petersburg University (SPU AC) was established in the Sobolev Astronomical Institute of the SPb University in 1998. The main activity of the SPU AC for the International VLBI Service before 2007 consisted of routine processing of 24-hour and 1-hour observational sessions for obtaining Earth Orientation Parameters (EOP) and rapid UT1-UTC values respectively. Due to staff changes in 2007 we had a gap in our submissions for IVS. In 2008 we resumed submitting results of 24-hour session processing. During 2009 the activities of the SPU AC continued unchanged.

## 2. Staff

The lecturer in astronomy of Saint Petersburg University, Dmitriy Trofimov, was in charge of the routine processing of the VLBI observations. General coordination and support for the activities of the SPU AC at the Astronomical Institute was performed by Prof. Veniamin Vityazev.

## 3. Activities in 2009

- In 2009 we continued the work resumed in 2008. The routine estimation of the five Earth Orientation Parameters was performed. The OCCAM package software (version 6.2) was used for current processing of VLBI data [1]. The time series is named spu00004.eops. It includes data obtained by the IRIS-A, NEOS-A, R1, and R4 observing programs, and it covers 21 years of observations (from January 2, 1989 until the end of 2009). The total number of processed experiments is about 1500, of which 103 VLBI sessions were processed in 2009. Our experience and the equipment of the Analysis Center was used for giving lectures and practical work on the basics of radio interferometry for the university students.
- All parameters have been adjusted using the Kalman filter technique. For all stations (except the reference one), the wet delay, clock offsets, clock rates, and troposphere gradients were estimated. Troposphere wet delay and clock offsets were modeled as a stochastic process such as a random walk. The clock rates and the troposphere gradients were considered to be constant parameters.
- The main details of the preparation of the EOP time series spu00004.eops are summarized below:
  - Data span: 1989.01–2009.12
  - CRF: fixed to ICRF-Ext.2

- TRF: VTRF2005 was used as an a priori TRF
- Estimated parameters:
  1. EOP:  $x, y, UT1 - UTC, d\psi, d\varepsilon$ ;
  2. troposphere: troposphere gradients were estimated as constant parameters, and wet troposphere delays were modeled as a random walk process;
  3. station clocks were treated as follows: offset as a random walk process, rate as a constant.
- nutation model: IAU 1980
- mapping function: VMF1
- technique: Kalman filter
- software: OCCAM v.6.2

#### 4. Future Plans

In 2010 we are going to continue our regular processing of the results of the VLBI sessions, as well as giving lectures and practical work for the students within a special course on radio astrometry which is included in the systematic curriculum of astronomical education in the SPb University.

#### References

- [1] O. Titov, V. Tesmer, J. Boehm, OCCAM v. 6. 0 Software for VLBI Data Analysis, In International VLBI Service for Geodesy and Astrometry 2004 General Meeting Proceedings, N. R. Vandenberg and K. D. Baver (eds.), NASA/CP-2004-212255, pp.267-271, 2004.

# Geoscience Australia Analysis Center

*Oleg Titov*

## Abstract

This report gives an overview of the activities of the Geoscience Australia IVS Analysis Center during 2009.

## 1. General Information

The Geoscience Australia (GA) IVS Analysis Center is located in Canberra. The Geodesy group operates as a part of the Geospatial and Earth Monitoring Division (GEMD).

## 2. Component Description

Currently the GA IVS Analysis Center contributes nutation offsets, EOP, and EOP rates on a regular basis for IVS-R1 and IVS-R4 networks and their predecessors (IRIS-A and NEOS-A). The EOP time series are available for 1983 to 2009. The CRF catalogs using a global set of VLBI data since 1979 are regularly submitted.

## 3. Staff

- Dr. Oleg Titov - project manager

## 4. Current Status and Activities

Several CRF solutions have been prepared using the OCCAM 6.2 software. VLBI data comprising 3,899 daily sessions from 25-Nov-1979 to 05-Oct-2009 have been used to compute several global solutions with different sets of reference radio sources. This includes 4,769,329 observational delays from 2,872 radio sources observed by 60 VLBI stations. The dipole and quadrupole systematic effects on the apparent proper motion of the reference radio sources (a magnitude of about 20 microarcsec/year) were indicated [1].

Station coordinates were also estimated using NNR and NNT constraints. The long-term time series of the station coordinates have been established to estimate the corresponding velocities for each station. The tectonic motion for the Gilcreek VLBI site after the Denali earthquake was modeled using an exponential function [2].

The adjustment has been done by least squares collocation [3], which considers the clock offsets, wet troposphere delays, and troposphere gradients as stochastic parameters with a priori covariance functions. The gradient covariance functions were estimated from GPS hourly values [4].

## 5. Geodetic Activity of the Australian Radiotelescopes

During 2009 two Australian radiotelescopes—Hobart and Parkes, operated by the University of Tasmania (UTAS) and Australia Telescope National Facility (ATNF), respectively—were involved in geodetic VLBI observations. GA's Geodesy Group supported the observations in different ways

including assistance with campaign scheduling.

The Parkes 64-meter telescope participated in four geodetic VLBI sessions in 2009 (RD0902, APSG24, APSG25, and CRF57). All of them were recorded with Mark 5B. One short session (2.5 hours) that included Parkes and Hobart26 was designed to observe lunar occultation of the radio source 1817-254. The primary goal of this project was to measure the moments of a quasar's disappearance behind the moon limb and reappearance. Six 24-hour sessions are planned for 2010 for further improvement of the ITRF and the ICRF in the Southern Hemisphere. This program is undertaken in cooperation with ATNF and UTAS.

## 6. New Geodetic VLBI Network

Geoscience Australia supported the installation work of the new Australian geodetic VLBI network during 2009. Two telescopes in Hobart and Katherine have been installed during 2009, and installation of the third one, in Yarragadee, will be completed shortly.

## References

- [1] Titov, O., Systematic effects in the radio source proper motion, In: Proceedings of the 19th European VLBI for Geodesy and Astrometry Meeting, Bordeaux, G. Bourda, P. Charlot and A. Collioud (eds.), 14–18, 2009.
- [2] Titov, O., P. Tregoning, Post-seismic motion of the Gilcreek geodetic sites following the November, 2002 Denali Earthquake, In: International VLBI Service for Geodesy and Astrometry 2004 General Meeting Proceedings, NASA/CP-2004-212255, N. R. Vandenberg and K. D. Baver (eds.), 496–500, 2004.
- [3] Titov, O., Estimation of subdiurnal tidal terms in UT1-UTC from VLBI data analysis, In: IERS Technical Notes 28, B. Kolaczek, H. Schuh, and D. Gambis (eds.), 11–14, 2000.
- [4] Haas, R., private communication.

## Report for 2009 from the Bordeaux IVS Analysis Center

*Patrick Charlot, Antoine Bellanger, Géraldine Bourda, Arnaud Collioud, Ming Zhang,  
Alain Baudry*

### Abstract

This report summarizes the activities of the Bordeaux IVS Analysis Center during the year 2009. The work was focused on (i) regular analysis of the IVS-R1 and IVS-R4 sessions with the GINS software package; (ii) systematic VLBI imaging of the RDV sessions and calculation of the corresponding structure index and compactness values; (iii) analysis of all available structure indices to identify potential defining sources for the ICRF2; (iv) continuation of our observational program to identify suitable radio sources for the link with the future Gaia frame; (v) development of a pipeline to model-fit VLBI structures in an automatic way; and (vi) simulations to assess the imaging capabilities of the VLBI2010 system and the accuracy of the corresponding structure corrections. Also to be mentioned is the enhancement of the Bordeaux VLBI Image Database and the construction of a dynamic web site for the IVS specific session dedicated to the International Year of Astronomy 2009. The IVS 10th Anniversary celebration held in Bordeaux on 25 March 2009 will remain as the highlight of the past year.

### 1. General Information

The “Laboratoire d’Astrophysique de Bordeaux” (LAB), formerly Bordeaux Observatory, is located in Floirac, near Bordeaux, in the southwest of France. It is funded by the University of Bordeaux and the CNRS (“Centre National de la Recherche Scientifique”). VLBI activities are primarily developed within the M2A team (“Métrologie de l’espace, Astrodynamique, Astrophysique”).

The contribution of the Bordeaux group to the IVS has been mostly concerned with the maintenance, extension, and improvement of the International Celestial Reference Frame (ICRF). This includes regular imaging of the ICRF sources and evaluation of their astrometric suitability, as well as developing specific VLBI observing programs for celestial frame applications.

In addition, the group is in charge of the VLBI component in the multi-technique GINS software package [1] as part of a collaborative effort within the French “Groupe de Recherches de Géodésie Spatiale” (GRGS) to combine VLBI and space geodetic data (SLR, GPS, DORIS) at the observation level. This effort also involves space geodesy groups in Toulouse, Grasse, and Paris.

### 2. Description of Analysis Center

The Bordeaux VLBI group routinely analyzes the weekly IVS-R1 and IVS-R4 sessions with the GINS software package. During the past year, specific test solutions for the CONT08 sessions have also been derived as a contribution to the multi-technique solutions produced by the GRGS within the framework of the “Combination at the Observation Level” (COL) Working Group. Further work was dedicated to software improvement and the implementation of operational procedures, e.g. to download automatically the newly-available data from the IVS web site on a regular basis.

Another activity is focused on producing VLBI maps of the ICRF sources by analysis of data from the RDV sessions. This analysis is conducted with the AIPS and DIFMAP calibration and imaging software packages. The aim of such regular imaging is to characterize the astrometric suitability of the sources based on the so-called “structure index”, and to compare source structural evolution and positional instabilities. Such studies are essential for a number of applications, e.g. for selecting sources of high astrometric quality for the realization of the ICRF2 or the Gaia link.

### 3. Scientific Staff

The IVS group in Bordeaux comprises the following six individuals who are involved either part-time or full-time in VLBI analysis and research activities, as described below:

- Patrick Charlot (20%): overall responsibility for Analysis Center work and data processing. His research interests include the ICRF densification, extension, and link to the Gaia frame, studies of source structure effects in astrometric VLBI data, and astrophysical interpretation.
- Antoine Bellanger (80%): engineer with background in statistics and computer science. His main role is to conduct initial VLBI data processing and to develop analysis tools as needed. He is also the web master for the M2A group.
- Géraldine Bourda (40%): post-doc fellow funded by the GRGS and the LAB. She is in charge of the VLBI analysis with GINS for combining space geodesy data at the observation level. She also leads a VLBI observational program for linking the ICRF and the future Gaia frame.
- Arnaud Collioud (100%): engineer with background in astronomy and interferometry. His tasks are to process the RDV sessions with AIPS and DIFMAP to image the sources, to maintain the Bordeaux VLBI Image Database (BVID), and to develop VLBI2010 simulations.
- Ming Zhang (50%): post-doc fellow funded by the CNRS. His work is targeted towards finding automatic ways to model-fit VLBI structures and extract physical information with the aim of studying the evolution of the sources from the BVID.
- Alain Baudry (10%): radioastronomy expert with specific interest in radio source imaging and astrometric VLBI.

### 4. Analysis and Research Activities during 2009

As noted above, a significant portion of our activity consists in imaging the sources observed during the RDV sessions on a systematic basis. During the past year, two such sessions were processed (RDV72 and RDV74), resulting in 365 VLBI images at either X or S band for 172 different sources. The imaging work load has been shared between the USNO and Bordeaux groups since 2007 (starting with RDV61): the USNO group processes the odd-numbered RDV sessions while the Bordeaux group processes the even-numbered ones. The VLBI images are used in a second stage to derive structure correction maps and visibility maps along with values for structure indices and source compactness (see [2, 3] for a definition of these quantities) in order to assess astrometric source quality. All such information is made available through the Bordeaux VLBI Image Database (BVID)<sup>1</sup>. At present, the BVID comprises a total of 1898 VLBI images (with links to an additional 6984 VLBI images from the Radio Reference Frame Image Database of the USNO at either S, X, K or Q band) along with 8882 structure correction maps and as many visibility maps. Apart from being regularly updated, the BVID has also been recently enhanced with new functionalities (quick source query from browser tool bar, image slide show, RSS feed,...).

Additional work aimed at studying the evolution of these structures over time is also pursued to exploit the BVID for astrophysics. For this purpose, a pipeline that automatically fit Gaussian components to the observed VLBI structures has been developed. Its results are repeatable,

---

<sup>1</sup>The BVID may be accessed at <http://www.obs.u-bordeaux1.fr/BVID>



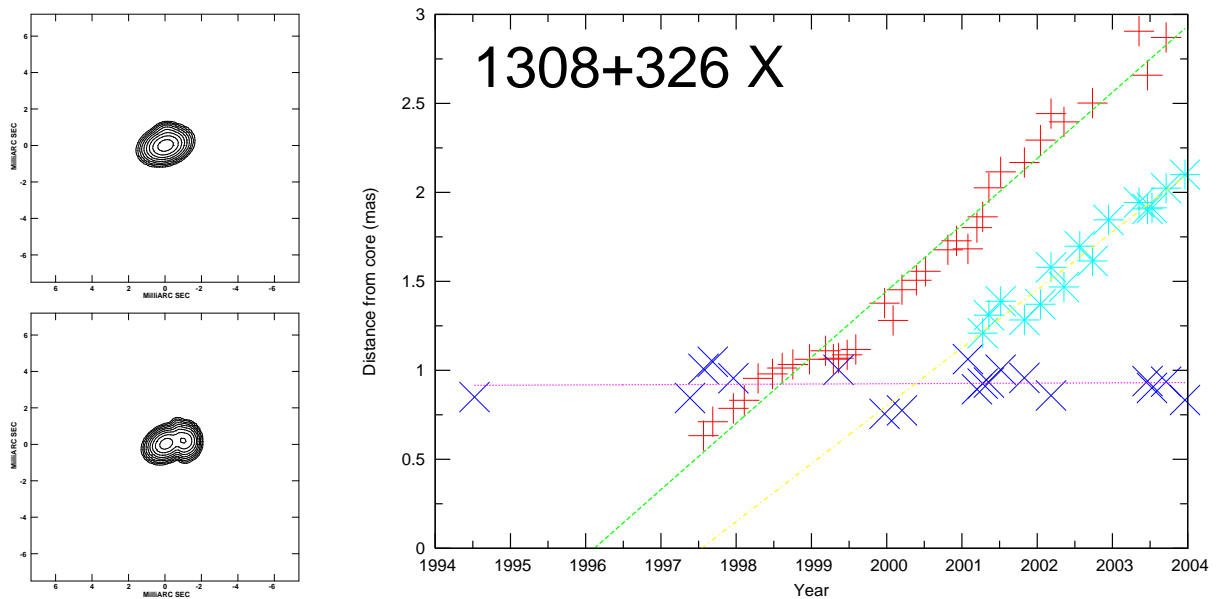

Figure 1. Structure models at X band for the ICRF source 1308+326 at epochs 1997.08 (upper left panel) and 1998.48 (lower left panel). The right panel shows the evolution with time of the component separation from the core. Three components are identified, with linear velocities of  $0.37 \pm 0.01$  mas/yr (green dashed line),  $0.33 \pm 0.02$  mas/yr (yellow dashed-dotted line), and  $0.00 \pm 0.01$  mas/yr (purple dotted line).

thereby providing objective comparisons between different data sets or reduction procedures, unlike traditional model-fitting which is usually user-dependent due to being accomplished manually. In a second step, the source models derived for all epochs are compared to estimate jet proper motions and flux density variability. This second pipeline calculates linear proper motion scatter to reduce the ambiguity in component sequencing and makes the most plausible component identification from epoch to epoch. Figure 1 illustrates our results for the ICRF source 1308+326. Comparison with results obtained manually are underway to assess the quality of this automatic reduction.

Another significant accomplishment of the past year is our contribution to the realization of the ICRF2. In this collaborative work, our task was focused on the selection of defining sources. The selection was made jointly with the Paris Observatory group based on (i) series of structure index, and (ii) arc source positions. This led to the identification of 295 defining sources with high astrometric quality and stable positions, which were adopted as a replacement for the ICRF at the XXVIIth IAU General Assembly held in Rio de Janeiro in August 2009 [4].

The work on the Gaia frame alignment [5] has made further progress, with calculation of structure indices for the 108 candidate sources imaged so far and preparation for the remaining observations. About half of the targets show point-like or quasi point-like structures. Assuming similar statistics for the remainder of the sample, we anticipate that a total of 200 new radio sources suitable for the Gaia alignment should be identified from this project ultimately.

Studies of the imaging capabilities of the VLBI2010 system continued during 2009 with focus on developing Monte Carlo simulations and calculating structure corrections from the simulated images in order to assess the accuracy of such structure corrections. The results of this work will be presented at the upcoming IVS General Meeting to be held in Hobart in February 2010.

## 5. Dissemination and Outreach

The Bordeaux VLBI group was involved in organizing two major IVS events during the past year: (i) the “VLBI 2009” series of meetings which were hosted in Bordeaux during the period 23–28 March 2009, and (ii) the International Year of Astronomy 2009 (IYA2009) specific IVS session which took place on 18 November 2009 and was meant both as an outreach and a scientific event.

The VLBI 2009 event comprised the 19th European VLBI for Geodesy and Astrometry Working Meeting, the 10th IVS Analysis Workshop, IVS Working Group meetings, and the 21st meeting of the IVS Directing Board. This event culminated with the celebration of the IVS 10th Anniversary on March 25 which was attended by 100 people, while being also streamed on the web in real-time.

The aim of the IYA09 session was to assemble the largest VLBI network ever and to observe as many ICRF2 defining sources as possible. A total of 34 stations was scheduled, while 243 of the 295 ICRF2 defining sources were observed. The contribution of the Bordeaux group consisted in making liaison with the official IYA2009 organization for outreach, preparing press releases, as well as building a dynamic web site displaying VLBI images of the observed sources in real time.

## 6. Outlook

Our plans for the coming year are focused on moving towards an operational analysis of the IVS-R1 and IVS-R4 sessions with the GINS software package. We will also continue imaging the RDV sessions in cooperation with USNO as well as evaluating the source astrometric suitability based on structure index and source compactness indicators. Additionally, we are planning to postprocess further the BVID data by using the pipeline that we have developed to automatically model-fit VLBI structures for astrophysical interpretation. Regarding the Gaia link, further imaging data should be acquired in the coming year, leading to the identification of additional suitable link sources. Simulations of the imaging capabilities of the VLBI2010 system will also continue with focus on the assessment of the accuracy of the structural corrections derived from these images. Finally, at the request of the IVS Directing Board, we are planning to extend the dynamic web site that was set up for the IYA2009 session in order to make it run for every IVS session.

## References

- [1] Bourda, G., Charlot, P., Biancale, R.: 2007, GINS: A New Tool for VLBI Geodesy and Astrometry, 18th EVGA Working Meeting, Eds. J. Böhm, A. Pany & H. Schuh, IGG Vienna, p. 59–63.
- [2] Fey, A. L., Charlot, P.: 1997, VLBA Observations of Radio Reference Frame Sources. II. Astrometric Suitability Based on Observed Structure, *ApJS*, 111, 95–142.
- [3] Charlot, P.: 2008, Astrophysical Stability of Radio Sources and Implication for the Realization of the Next ICRF, 5th IVS General Meeting, St Petersburg, Eds. A. Finkelstein & D. Behrend, p. 345–354.
- [4] IERS Technical Note 35: 2009, The Second Realization of the International Celestial Reference Frame by Very Long Baseline Interferometry, Eds. A. L. Fey, D. Gordon & C. S. Jacobs, Frankfurt am Main: Verlag des Bundesamts für Kartographie und Geodäsie, 204 pages.
- [5] Bourda, G., Charlot, P., Porcas, R., Garrington, S.: 2008, Multi-Step VLBI Observations of Weak Extragalactic Radio Sources to Align the ICRF and the Future GAIA Frame, 5th IVS General Meeting, St Petersburg, Eds. A. Finkelstein & D. Behrend, p. 25–29.

# BKG/DGFI Combination Center Annual Report 2009

*Wolfgang Schwegmann, Robert Heinkelmann, Michael Gerstl*

## Abstract

This report summarizes the activities of the BKG/DGFI Combination Center in 2009 and outlines the planned activities for the year 2010. The main goal in 2009 was to perform the operational combination of the IVS Rapid EOP series (R1 and R4 sessions). Since October 1, 2009 these combinations have been performed at the BKG/DGFI Combination Center. In 2010 the responsibility for the operation of the IVS quarterly solutions should also be taken over from the IVS Analysis Coordinator.

## 1. General Information

The BKG/DGFI Combination Center was established in October 2008 as a joint effort of the Federal Agency for Cartography and Geodesy (Bundesamt für Kartographie und Geodäsie, BKG) and the German Geodetic Research Institute (Deutsches Geodätisches Forschungsinstitut, DGFI). The participating institutions, as well as the tasks and the structure of the IVS Combination Center, have been described in [3]. The tasks comprise quality control and a timely combination of the session-based intermediate results of the IVS Analysis Centers into a final combination product (e.g., Earth Orientation Parameters, EOP). After consultation with the IVS Analysis Coordinator, the combination results will be released as official IVS products. The Combination Center is also expected to contribute to the generation of the official IVS input to any ITRF activities. These tasks should be performed on an operational basis.

## 2. Component Description

The BKG/DGFI Combination Center performs a combination of session-based results of the IVS Analysis Centers on an operational basis. The strategy for the combination has been adapted from the combination process developed and performed by the IVS Analysis Coordinator (cf. [1], [2]). In 2009 the responsibility for the combination of the two IVS EOP series (rapid and quarterly solutions) on the basis of datum-free normal equations in SINEX format has been taken over by the Combination Center.

At BKG the following Combination Center functions are performed:

- Ensuring quality control of the Analysis Center results: Checking the format of the results and their suitability for combination, performing identification and reduction of outliers, comparing the Analysis Centers' results against each other, and comparing the results w.r.t. external time series, e.g. from IERS or IGS.
- Providing feedback to the Analysis Centers: Quality control results will be available at the BKG/DGFI IVS Combination Center Web page [4]. If preferred by the Analysis Centers, the results will be provided by e-mail, too.
- Creating high quality combination products and performing timely archiving and distribution: Combination products will be created using the DGFI DOGS software package, which operates by combining of unconstrained (free) normal equations.

- Submitting official IVS combination products to the IERS: The produced official IVS combination products will be submitted to the responsible IERS components as requested by the IERS. This will be supported by the staff of the IERS Central Bureau at BKG.
- Placing final results in IVS Data Centers: Final results will be placed in the BKG Data Center. This will be assisted by the staff of the BKG Data Center in Leipzig.
- Generating official IVS input to the ITRF: Official IVS input to the ITRF will be created as combined weekly solutions in SINEX format.

DGFI will be in charge of the following Combination Center functions:

- Developing state-of-the-art combination procedures: State-of-the-art combination procedures will be developed mainly at DGFI. This work, as well as the following item, is also related to DGFI's efforts as an IERS Combination Research Center and an IERS ITRS Combination Center.
- Performing software development and documentation: At DGFI the DOGS software package will be continuously updated by implementing the developed state-of-the-art combination procedures.
- Adhering to IERS Conventions: The DGFI DOGS software package is continuously updated to be in accordance with the IERS Conventions, as much as possible.

### 3. Staff

The list of the staff members of the BKG/DGFI Combination Center in 2009 is given in Table 1.

Table 1. Staff members of the BKG/DGFI Combination Center.

Name	Affiliation	Function	E-Mail
Michael Gerstl	DGFI	Software maintenance	gerstl@dgfi.badw.de
Robert Heinkelmann	DGFI	Combination strategies	heinkelmann@dgfi.badw.de
Alexander Lothhammer	BKG	Hardware maintenance	alexander.lothhammer@bkg.bund.de
Wolfgang Schwegmann	BKG	Combination	wolfgang.schwegmann@bkg.bund.de

### 4. Current Status and Activities

In 2009 the software packages necessary for the combination process were installed and tested. Extensive test combination runs were performed in cooperation with Sarah Böckmann from the IVS Analysis Coordinator's team. Operational combination of the IVS Rapid EOP series (R1 and R4 sessions) was taken over from the IVS Analysis Coordinator's team on October 1, 2009. Also, as described in [2], in 2009 six IVS Analysis Centers (BKG, DGFI, GSFC, IAA, OPA, and USNO) contributed to the IVS combined products. The rapid solutions contain only R1 and R4 sessions,

and new data points are added twice a week as soon as the SINEX files of at least four IVS Analysis Centers are available. The results of the combination process are placed in the BKG Data Center in Leipzig. The combined rapid EOP series, as well as the results of the quality control of the Analysis Center results, are also available at the BKG/DGFI Combination Center Web page [4]

To prepare the operational combination of the IVS quarterly solutions, test runs were performed in 2009. Starting in 2010 these quarterly solutions should be performed by the BKG/DGFI Combination Center, too.

## 5. Plans for 2010

In 2010 the work of the BKG/DGFI Combination Center will focus on the following:

- Taking over responsibility for the combination of the IVS quarterly solutions and performing these combinations on an operational basis.
- Performing quality control of improved Analysis Center solutions and using these solutions in the routine combination.
- Including a new Analysis Center solution based on the GEOSAT software and provided by Halfdan Pascal Kierulf from the Geodetic Institute, Norwegian Mapping Authority (STATKART), Honefoss, Norway.
- Maintaining and extending available information on the combination procedure and combination results available at the Combination Center Web page [4].

## Acknowledgements

The establishment of the BKG/DGFI Combination Center has been strongly supported by the IVS Analysis Coordinator's team, respectively Sarah Böckmann. Without her extensive help in installing the software and performing the combination process, the operational combination would not have been possible in such a short time at the BKG/DGFI Combination Center.

## References

- [1] Nothnagel, A., Böckmann, S., Artz, T., Analysis Coordinator Report, In: International VLBI Service for Geodesy and Astrometry 2007 Annual Report, NASA/TP-2008-214162, D. Behrend and K. D. Baver (eds.), 16–17, 2008.
- [2] Nothnagel, A., Böckmann, S., Artz, T., Analysis Coordinator Report, In: International VLBI Service for Geodesy and Astrometry Annual Report 2008, NASA/TP-2009-214183, D. Behrend and K. D. Baver (eds.), 80–82, 2009.
- [3] Schwegmann, W., Gerstl, M., Heinkelmann, R., BKG/DGFI Combination Center Annual Report 2008, In: International VLBI Service for Geodesy and Astrometry Annual Report 2008, NASA/TP-2009-214183, D. Behrend and K. D. Baver (eds.), 250–252, 2009.
- [4] <http://ida.bkg.bund.de/IVS/index.html>  
BKG/DGFI Combination Center Web page.

# Matera CGS VLBI Analysis Center

*Roberto Lanotte, Giuseppe Bianco*

## Abstract

This paper reports the VLBI data analysis activities at the Space Geodesy Center (CGS), Matera, from January 2009 through December 2009 and the contributions that the CGS intends to provide for the future as an IVS Analysis Center.

## 1. General Information

The Matera VLBI station became operational at the Space Geodesy Center (CGS) of the Italian Space Agency (ASI) in May 1990. Since then, it has been active in the framework of the most important international programs. VLBI data analysis activities are performed at CGS for a better understanding of tectonic motions with specific regard for the European area. The CGS, operated by e-geos (formerly Telespazio) on behalf of ASI, provides full scientific and operational support using the main space geodetic techniques: VLBI, SLR, and GPS.

## 2. Staff at CGS contributing to the IVS Analysis Center

- Dr. Giuseppe Bianco, responsible for CGS/ASI (primary scientific/technical contact).
- Dr. Cinzia Luceri, responsible for scientific activities, e-geos.
- Dr. Roberto Lanotte, geodynamics data analyst, e-geos.

## 3. Current Status and Activities

### 3.1. Global VLBI Solution cgs2008a

The main VLBI data analysis activities at the CGS in the year 2009 were directed towards the realization of a global VLBI solution, named cgs2008a, using the CALC/SOLVE software (developed at GSFC). The solution activities, started in 2008, ended in May 2009, when the solution sections (crf, trf, and eop) were published in the IVS archives. The main, final, characteristics of this solution are:

- Data span:  
1979.08.03 - 2008.12.30 (3601 sessions)
- Estimated Parameters:
  - Celestial Frame:  
right ascension and declination as global parameters for 721 sources
  - Terrestrial Frame:  
Coordinates and velocities for 90 stations as global parameters
  - Earth Orientation:  
Unconstrained X pole, Y pole, UT1, Xp rate, Yp rate, UT1 rate, dps and deps.

### **3.2. IVS Tropospheric Products**

Regular submission of tropospheric parameters (wet and total zenith path delays, and east and north horizontal gradients) for all VLBI stations observing in the IVS R1 and R4 sessions continued during 2009. At present 707 sessions have been analyzed and submitted, covering the period from 2002 to 2009. The results are available at the IVS products ftp sites.

### **3.3. IVS Product “Time Series of Baseline Lengths”**

Regular submission of station coordinate estimates, in SINEX files, continued during 2009 for the IVS product “Time Series of Baseline Lengths”. This is composed of 3475 sessions, from 1979 to 2009.

### **3.4. CGS Contribution to IERS EOP Operational Series**

Since 2008, CGS has been delivering IERS R1 and R4 session EOP estimates as a regular contribution to the IERS EOP operational series. The whole cgs2007a solution, available when the contribution started, has been delivered to IERS as a reference series updated by the periodic EOP solution submission.

## **4. Future Plans**

- Continue and improve the realization of our global VLBI solution, providing its regular update on time.
- Continue to participate in IVS analysis projects, providing the datum-free normal equations.

# DGFI Analysis Center Annual Report 2009

*Robert Heinkelmann, Michael Gerstl, Manuela Seitz, Hermann Drewes*

## Abstract

This report summarizes the activities of the DGFI Analysis Center in 2009 and outlines the planned activities for 2010.

## 1. General Information and Component Description

The German Geodetic Research Institute (Deutsches Geodätisches Forschungsinstitut, DGFI) is an autonomous and independent research institute hosted at the Bavarian Academy of Sciences (BADW) located in Munich. It is run by the Free State of Bavaria and it is evaluated every four years by a scientific advisory board consisting of four international experts nominated by the International Association of Geodesy (IAG) and of three professors working at German universities nominated by the German Geodetic Commission (Deutsche Geodätische Kommission, DGK). The research covers all fields of geodesy and includes participation in national and international projects as well as functions in international bodies (see also <http://www.dgfi.badw.de>).

## 2. Staff

The DGFI IVS AC (<http://www.dgfi.badw.de/index.php?id=126&L=2>) is operated by Robert Heinkelmann and Manuela Seitz. The recent developments and numerical optimizations of OC-CAM were almost completely carried out by Michael Gerstl, who is a great gain for our team. Our activities are managed by Hermann Drewes, who also supports our work with his experience.

## 3. Current Status and Activities

- IVS Operational Analysis Center at DGFI:

The first year for DGFI as an operational analysis center has passed. DGFI routinely processes the standard IVS sessions (currently the two rapid turnaround sessions R1 and R4) and additional sessions of the geodetic and astrometric programs run by IVS, and it delivers datum free normal equations in SINEX format. The duty to process and submit sessions within 24 hours after database (DB) version 4 (or higher) is available demands a certain degree of automation of the analysis and can become problematic in the rare case, that operators are out-of-office. A small but important step towards decreasing the product latency could be achieved with the help of the Institute of Applied Astronomy (IAA), St. Petersburg, which provided routines enabling the format transformation from DB to NGS. In this context, we want to thank IAA for the routines again.

- Contribution to the new conventional terrestrial reference frame: ITRF2008:

Our VLBI group was able to successfully compute and contribute a solution including more than 3000 session SINEX files for the new realization of the terrestrial reference system ITRF2008. The VLBI intra-technique combination, an intermediate step towards the inter-



technique combination, already proved to be of better quality than the contribution to its predecessor: ITRF2005.

- Implementation of the new conventional model of thermal deformations of VLBI antennas:  
A new conventional model of antenna thermal deformation developed by the IVS Analysis Coordinator (Nothnagel, 2009) was implemented in and tested with our OCCAM VLBI software (Heinkelmann et al., 2009a). The difference between two VLBI solutions using identical analysis strategies but switching the new thermal deformation model on (A) or off (B) shows insignificant mean variations of the station coordinates but pronounced seasonal signals strongly correlated with the local air temperature. Maximal amplitudes of 3 mm can be found at sites with large antenna dimensions and strong seasonal temperature variations, such as GILCREEK, Fairbanks, Alaska and ALGOPARK, Algonquin Park, Canada. Station coordinate repeatabilities overall slightly improve, if the thermal deformations are applied (solution A). The strongest effect imposed by the thermal deformation model can be found on the epochwise network scale parameter of a seven parameter similarity transformation between A and B (Figure 1).

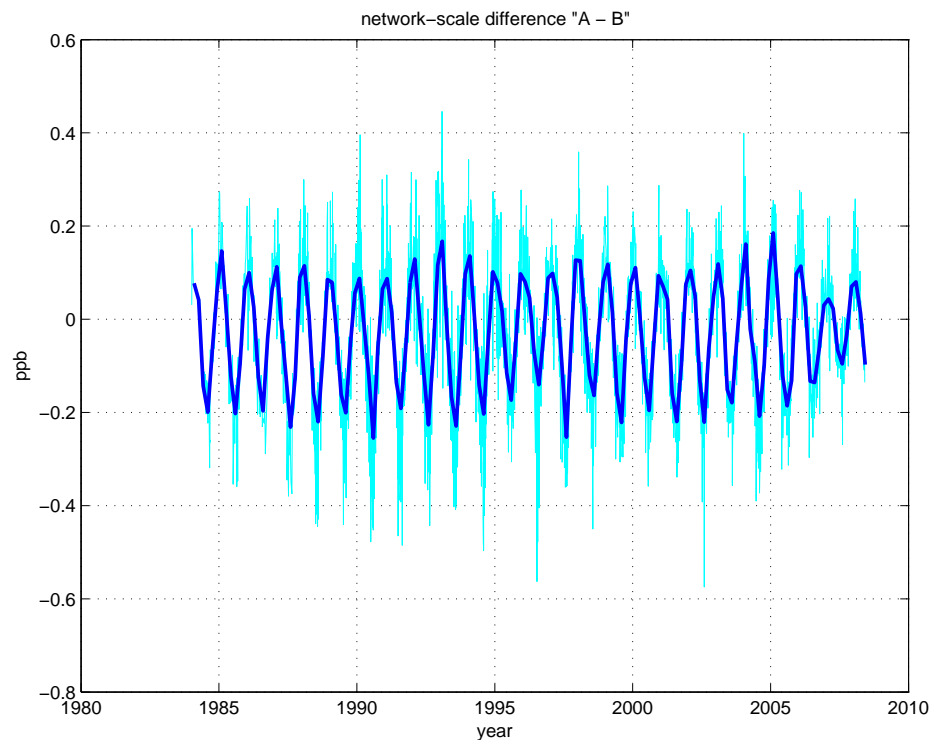

Figure 1. Difference in sessionwise network-scale determined by a 7-parameter similarity transformation.

- Comparison of ionospheric parameters:  
In cooperation with NICT the vertical total electron content (VTEC) determined by GNSS, radio occultation with COSMIC/Formosat-3 satellite constellation, radar altimetry, and VLBI was compared at DGFI. The very good agreement in particular between GNSS- and

VLBI-derived ionosphere parameters motivates us to consider a combination including the aforementioned techniques (Heinkelmann et al., 2009b).

- Atmospheric pressure loading:

In 2009 there was a lot of discussion concerning atmospheric pressure loading. One point of view is that corrections have to be applied at the observation level in order to avoid a transfer of the effects onto other network stations due to the necessary network condition equations. In this case, however, loading corrections have to be known with appropriate precision, and that is the concern among colleagues who decline the correction at the observation level. If the corrections are not precise enough, they will worsen the observations and consequently degrade the parameters. In this context, the question is whether the small but significant improvement of station position repeatabilities in the case of applying corrections at the observation level is sufficient evidence for the correctness and accuracy of present atmospheric loading models. The fact that present models do not differ too much among themselves does not justify the application, because there might be of course the same systematics inherent in all the models (Böhm et al., 2009).

- Theoreticals considering VLBI2010 operability:

The conventional model of VLBI theoretical delays (IERS, 2004) based on the consensus model provides an accuracy of 1 ps. Considering the simulated performance of the VLBI2010 system, the model is to be revisited in order to account for an accuracy of about 0.3 ps. In this case, the gravitational time delay (Shapiro delay) will have to consider not only the Sun and the Earth, which is today's practice, but also Jupiter, Saturn, Venus, and the Moon (Heinkelmann & Schuh, 2009).

- IVS tropospheric combination:

In 2009 the troposphere combined products of IVS were migrated from the Institute of Geodesy and Geophysics (IGG), Vienna, to DGFI, Munich, where an interactive Web page was set up with the help of Christian Schwatke (DGFI). The new Web presentation allows the choice of any subset of Analysis Center solutions and the display of their combined solution, providing a better overview. The new Web pages are accessible through <http://www.dgfi.badw.de/?194> and <http://www.dgfi.badw.de/?196>.

- Rearrangement of the OCCAM software used and developed at DGFI:

The IVS OCCAM Working Group, chaired by Oleg Titov, Geoscience Australia (Canberra, Australia) has been responsible for the development and maintenance of OCCAM, one of the most frequently used VLBI analysis software packages within IVS, for many years. With IGG discontinuing maintenance of OCCAM, DGFI decided to further develop its own version of OCCAM. Many smaller and bigger changes of the former OCCAM 6.1. LSM (Linux version) code have brought DGFI's VLBI software much closer to DOGS, the DGFI Orbit and Geodetic Parameter Estimation Software Package (Gerstl et al., 2000). In the near future, modifications might go so far that DGFI's OCCAM version might become a part of DOGS.

## 4. Future Plans

At the DGFI IVS AC we want to continue and deepen our investigations concerning the atmosphere, i.e. the ionosphere and the neutral atmosphere. In addition, the migration of OCCAM into the DOGS environment will be one of our main goals in 2010. For operational VLBI analysis we want to further automate the analysis procedure and to extend our product portfolio.

## References

- [1] Böhm J., R. Heinkelmann, P.J. Mendes Cerveira, A. Pany, H. Schuh: Atmospheric loading corrections at the observation level in VLBI analysis. *JoGE*, Vol. 83, No. 11, doi:10.1007/s00190-009-0329-y, 2009
- [2] Gerstl M., R. Kelm, H. Müller, W. Ehrnsperger: DGFI Orbit and Geodetic Parameter Estimation Software. Combination and Solution. Deutsches Geodätisches Forschungsinstitut Interner Bericht Nr. MG/01/1995/DGFI, in German, 2000
- [3] Heinkelmann R., M. Seitz, D. Angermann, H. Drewes: Effects of the new conventional model of VLBI antenna thermal deformation on the terrestrial reference frame. Poster at EGU General Assembly, Vienna, Austria, 2009a
- [4] Heinkelmann R., T. Hobiger, M. Schmidt: Contribution of VLBI to a combined model of the ionosphere. Poster at EGU General Assembly, Vienna, Austria, 2009b
- [5] Heinkelmann R. and H. Schuh: Very Long Baseline Interferometry: Accuracy limits and relativistic tests. In: *Proceedings IAU Symposium No. 261, Relativity in Fundamental Astronomy*, S.A. Klioner, P.K. Seidelmann, M.H. Soffel (Eds.), doi:10.1017/S1743921309990524, 2009
- [6] Nothnagel A.: Conventions on thermal expansion modeling of radio telescopes for geodetic and astrometric VLBI. *JoGE*, Vol. 83, No. 8, doi:10.1007/s00190-008-0284-z, 2009

# FFI Analysis Center

*Per Helge Andersen*

## Abstract

FFI's contribution to the IVS as An Analysis Center focuses primarily on a combined analysis at the observation level of data from VLBI, GPS, and SLR using the GEOSAT software. This report briefly summarizes the current status of analyses performed with the GEOSAT software. FFI is currently an Analysis Center for IVS and ILRS and a Technology Development Center for IVS.

## 1. Introduction

A number of co-located stations with more than one observation technique have been established. In principle, all instruments at a given co-located station move with the same velocity, and it should be possible to determine a single set of coordinates and velocities for each co-located site. In addition, a constant eccentricity vector from the reference point of the co-located station to each of the individual phase centers of the co-located antennas is estimated using constraints in accordance with a priori information given by ground surveys. One set of Earth orientation parameters (EOP) and geocenter coordinates can be estimated from all involved data types. The present dominating error source of VLBI is the water content of the atmosphere, which must be estimated. The introduction of GPS data with a common VLBI and GPS parameterization of the zenith wet delay and atmospheric gradients will strengthen the solution for the atmospheric parameters. The inclusion of SLR data, which is nearly independent of water vapor, gives new information which will help in the de-correlation of atmospheric and other solve-for parameters and will lead to more accurate parameter estimates. These, and many more advantages with the combination of independent and complementary space geodetic data at the observation level, are fully provided by the GEOSAT software developed at FFI.

The Norwegian Mapping Authority (NMA) and FFI have started a close cooperation in the analysis of space geodetic data using the GEOSAT software. NMA has initiated a collaboration with the IVS with a goal of becoming a full IVS Analysis center with contributions obtained from VLBI data using the GEOSAT software. Dr. Per Helge Andersen is responsible for the maintenance of the software. Dr. Halfdan Kierulf (also with NMA) will be responsible for the daily analyses. A software package has been written to transform the output from GEOSAT to SINEX format. A large number of session-by-session SINEX files have been combined with solutions from the IVS Analysis centers, and the results seem quite encouraging.

## 2. Staff

Dr. Per Helge Andersen—Research Professor of Forsvarets forskningsinstitutt (FFI) and Institute of Theoretical Astrophysics, University of Oslo.

## The BKG/IGGB VLBI Analysis Center

*Volkmar Thorandt, Axel Nothnagel, Gerald Engelhardt, Dieter Ullrich, Thomas Artz,  
Sarah Böckmann, Judith Pietzner*

### Abstract

In 2009, the activities of the BKG/IGGB VLBI Analysis Center, as in previous years, consisted of routine computations of Earth orientation parameter (EOP) time series and of a number of research topics in geodetic VLBI. The VLBI group at BKG continued its regular submissions of time series of tropospheric parameters and the generation of daily SINEX (Solution INdependent EXchange format) files. Quarterly updated solutions have been computed to produce terrestrial reference frame (TRF) and celestial reference frame (CRF) realizations. Routine computations of the UT1–UTC Intensive observations include all sessions of the Kokee–Wettzell and Tsukuba–Wettzell baselines and the networks Kokee–Svetloe–Wettzell and Ny-Ålesund–Tsukuba–Wettzell. The data analysis was refined and the work for the IERSU Working Group on ICRF2 was completed. At IGGB, the emphasis has been placed on individual research topics.

### 1. General Information

The BKG/IGGB VLBI Analysis Center has been established jointly by the Federal Agency for Cartography and Geodesy (BKG), Leipzig, and the Institute of Geodesy and Geoinformation of the University of Bonn (IGGB). Both institutions maintain their own analysis groups in Leipzig and Bonn but cooperate intensely in the field of geodetic VLBI. The responsibilities include data analysis for generating IVS products as well as special investigations with the goal of increasing accuracy and reliability. BKG is responsible for the computation of time series of EOP and tropospheric parameters, for the generation of SINEX files for 24-hour VLBI sessions and 1-hour Intensive sessions, and for the generation of quarterly updated global solutions for TRF and CRF realizations. Besides data analysis, the BKG group is also responsible for the scheduling of the Tsukuba–Wettzell INT2 UT1–UTC observing sessions. IGGB continues to host the office of the IVS Analysis Coordinator and carries out special investigations within the techniques of geodetic and astrometric VLBI. Details of the research topics of BKG and IGGB are listed in Section 2.

### 2. Data Analysis

At BKG, the Mark 5 VLBI data analysis software system Calc/Solve, release of December 05, 2008 [4], has been used for VLBI data processing. It is running under Fortran 90 on a PC with the GNU/Linux 2.6.5-7.97-smp operating system. The software includes the new Calc 10 implementation for complying with the IAU 2000 Resolutions and the IERS Conventions 2003. The Vienna Mapping Function (VMF1) implemented in a Solve version modified in Leipzig for this purpose was used for all data analyses. There were no negative effects in the daily update of the VMF1 data from the server of the Technical University of Vienna. In addition, an independent technological software environment for the Calc/Solve software is available. The latter is used for linking up the Data Center management with the pre- and post-interactive parts of the EOP series production and for monitoring all Analysis and Data Center activities.

- **Processing of correlator output**

The BKG group continued the generation of calibrated databases for the sessions correlated

at the MPIfR/BKG Mark 5 Astro/Geo Correlator at Bonn (e.g., EURO, OHIG, and T2) and submitted them to the IVS Data Centers.

- **Scheduling**

BKG continued scheduling the INT2 Intensive sessions, which are observed on the baseline TSUKUBA-WETTZELL. Altogether 104 schedule files were created in 2009.

- **BKG EOP time series**

A new EOP time series bkg00012 was created. The data analysis was done with the thermal expansion modelling published in [6]. Instead of the high frequency EOP model hf1102a, the short period ocean tide and nutation contributions to EOP in accordance with the IERS Conventions 2003 were used. For modelling of ocean tide loading, the model FES2004 [5], as made available from H. G. Scherneck [7], was applied. Furthermore, the new a priori set of coordinates and velocities, VTRF2008a, generated as input to ITRF2008 [3] was used in data processing.

Each time after the preprocessing of any new VLBI session (correlator output database version 1), a new global solution with 24-hour sessions since 1984 has been computed, and the EOP time series bkg00012 has been extracted. Altogether 3953 sessions have been processed. The main parameter types in this solution are globally estimated station coordinates and velocities together with radio source positions. The datum definition was realized by applying no-net-rotation and no-net-translation conditions for 26 selected station positions and velocities with respect to VTRF2008a and a no-net-rotation condition for 212 defining sources with respect to ICRF/ICRF-Ext.1. The station coordinates of the telescopes AIRA (Japan), BADARY (Russia), CHICHI10 (Japan), CTVAJSTJ (Canada), DSS13 (USA), PT\_REYES (USA), SEST (Chile), SINTOTU3 (Japan), WIDE85.3 (USA), and YEBES40M (Spain) were estimated as local parameters in each session.

The UT1-UTC Intensive time series bkgint07 was replaced by bkgint08 with the new models mentioned above. In addition to the observations of the two baselines KOKEE-WETTZELL and TSUKUBA-WETTZELL, also the networks KOKEE-SVETLOE-WETTZELL and NYALES20-TSUKUBA-WETTZELL, each with a duration of about 1 to 1.5 hours, were processed regularly. The series bkgint08 was generated with fixed TRF (VTRF2008a) and fixed CRF derived from the global BKG solution for EOP determination. The estimated parameter types were only UT1-TAI, station clock, and zenith troposphere. A total of 3112 UT1 Intensive sessions were analyzed for the period between 1999.01.01 and 2009.12.31.

- **Quarterly updated solutions for submission to IVS**

In 2009, one quarterly updated solution was computed for the IVS products TRF and CRF. There are no differences in the solution strategy compared to the continuously computed EOP time series bkg00012. The results of the radio source positions were submitted to IVS in IERS format. The TRF solution is available in SINEX format, version 2.1, and includes station coordinates, velocities, and radio source coordinates together with the covariance matrix, information about constraints, and the decomposed normal matrix and vector. In the frame of the ICRF2 working group, a solution for the ICRF2 catalog and the corresponding TRF was also created with special requirements for the CRF.

- **Tropospheric parameters**

The VLBI group of BKG continued regular submissions of long time series of tropospheric

parameters to the IVS (wet and total zenith delays, and horizontal gradients) for all VLBI sessions since 1984. The tropospheric parameters were extracted from the standard global solution bkg00012 and transformed into SINEX format.

- **Daily SINEX files**

The VLBI group of BKG also continued regular submissions of daily SINEX files for all available 24-hour sessions for the IVS combined products [2] and for the IVS time series of baseline lengths. In addition to the global solutions, independent session solutions with the new models mentioned above were computed for the station coordinates, EOP parameters, and nutation parameters. The a priori datum for TRF is defined by the VTRF2008a, and the fixed CRF derived from the complete global BKG solution for EOP determination is used for the a priori CRF information.

- **SINEX files for Intensive sessions**

The parameter types are station coordinates, pole coordinates and their rates, and UT1-TAI and its rate. But only the normal equations stored in the SINEX files are important for further combination with other space geodetic techniques.

### 3. Research Topics

- **Further work for ICRF2**

The special investigations at BKG concerning long-term stability of radio sources in VLBI analysis on the basis of time series of radio source positions in the frame of the ICRF2 working group were completed [8]. 226 stable radio sources with an axis stability of 0.01 mas could be identified. They include 100 ICRF2 axis-defining sources determined independently from the method applied in the ICRF2 working group. It was found that 29 radio sources with a source structure index of less than 3.0 are stable enough that they could be used to increase the number of 295 ICRF2 defining sources.

- **CONT08 Pre-release tests**

Prior to the release of the correlator output of the CONT08 sessions, a preliminary quality check was performed at Bonn in order to avoid inconsistencies in the data. For this, preliminary solutions were calculated for the 15 individual sessions, and the site coordinate repeatabilities were checked. The data proved to be according to the specifications, and the databases were released five days later.

- **Input to ITRF2008**

IGGB has computed its own solution for IVS' input to ITRF2008. For 4370 sessions with 112 sites from 1979.7 to 2009.0, datum-free normal equations have been generated from analyses with the Calc/Solve software installed at Bonn [3].

- **Sub-daily EOP determinations**

At Bonn, investigations of sub-daily EOP variations in CONT02, CONT05, and CONT08 data have been carried out and the CONT08 results have been published [1]. It turned out that the drop-out of Gilcreek and Algonquin Park weakened the network for sub-daily EOP determinations, and the results are slightly noisier than those of CONT05. Although scheduled for an atmospherically more active period in August (compared to September 2005 and October 2002), no stronger atmospherically induced signals were found in the CONT08

data. Amplitudes at non-tidal periods, e.g., at 6 h and 8 h, could be detected with different characteristics for the three campaigns.

In addition, investigations into the estimation of an empirical sub-daily EOP model have been performed. Here, three different approaches for the computation of a sub-daily EOP model have been tested and compared: (a) the estimation based on EOP time series, (b) based on normal equation systems and (c) based on the observation equation systems. Moreover, the stability and reliability of the estimated coefficients have been assessed by comparing the coefficients estimated from data of different time spans.

#### 4. Personnel

Table 1. Personnel at BKG/IGGB Analysis Center

Thomas Artz	IGGB	+49-228-733563	thomas.artz@uni-bonn.de
Sarah Böckmann	IGGB	+49-228-733563	boeckmann@uni-bonn.de
Gerald Engelhardt	BKG	+49-341-5634438	gerald.engelhardt@bkg.bund.de
Axel Nothnagel	IGGB	+49-228-733574	nothnagel@uni-bonn.de
Judith Pietzner	IGGB	+49-228-733565	judith.pietzner@igg.uni-bonn.de
Volkmar Thorandt	BKG	+49-341-5634285	volkmar.thorandt@bkg.bund.de
Dieter Ullrich	BKG	+49-341-5634328	dieter.ullrich@bkg.bund.de
Reiner Wojdziak	BKG	+49-341-5634286	reiner.wojdziaak@bkg.bund.de

#### References

- [1] Artz T., Böckmann S., Nothnagel A., Steigenberger P. (2010) Sub-diurnal variations in the Earth's rotation from continuous VLBI campaigns, *J. of Geophysical Research*, doi:10.1029/2009JB006834, in press.
- [2] Böckmann S., Artz T., Nothnagel A., Tesmer V. (2010) International VLBI Service for Geodesy and Astrometry: EOP combination methodology and quality of the combined products, *J. of Geophysical Research*, doi:10.1029/2009JB006465, in press.
- [3] Böckmann S., Artz T., Nothnagel A., (2010) VLBI terrestrial reference frame contributions to ITRF2008, *J. of Geodesy*, doi:10.1007/s00190-009-0357-7, in press.
- [4] GSFC, NASA (2008): Release of Mark 5 VLBI Analysis Software Calc/Solve from December 05, 2008 (Web reference: <http://gemini.gsfc.nasa.gov/solve>).
- [5] Lyard, F., F. Lefevre, T. Letellier, and O. Francis (2006), Modelling the global ocean tides: modern insights from fes2004. *Ocean Dynamics*, Vol. 56, 394–415, DOI 10.1007/s10236-006-0086-x.
- [6] Nothnagel A. (2008) Short Note: Conventions on thermal expansion modelling of radio telescopes for geodetic and astrometric VLBI; *Journal of Geodesy*, DOI: 10.1007/s00190-008-0284-z.
- [7] FES2004: (Web reference: <http://www.oso.chalmers.se/~loading/>).
- [8] Engelhardt G., Thorandt V. (2010): Long-Term Stability of Radio Sources in VLBI Analysis. In: IVS General Meeting Proceedings 2010, Hobart, Tasmania, Australia (in preparation).



## GSFC VLBI Analysis Center

*David Gordon, Chopo Ma, Dan MacMillan, John Gipson, Karen Baver, Sergei Bolotin,  
Karine Le Bail*

### Abstract

This report presents the activities of the GSFC VLBI Analysis Center during 2009. The GSFC Analysis Center analyzes all IVS sessions, makes regular IVS submissions of data and analysis products, and performs research and software development aimed at improving the VLBI technique.

## 1. Introduction

The GSFC VLBI Analysis Center is located at NASA's Goddard Space Flight Center in Greenbelt, Maryland. It is part of a larger VLBI group which also includes the IVS Coordinating Center, the CORE Operation Center, a Technology Development Center, and a Network Station. The Analysis Center participates in all phases of geodetic and astrometric VLBI analysis, software development, and research aimed at improving the VLBI technique.

## 2. Activities

### 2.1. Analysis Activities

The GSFC analysis group analyzes all IVS sessions, using the *Calc/Solve* system, and it performs the *AIPS* fringe fitting and *Calc/Solve* analysis of the VLBA-correlated RDV sessions. The group submits the analyzed databases to IVS for all R1, RDV, R&D, CONT08, NEOS INT01, and INT03 sessions. During 2009, the group processed and analyzed 171 24-hour sessions (53 R1, 52 R4, 6 RDV, 10 R&D, 15 CONT08, 6 EURO, 6 T2, 4 APSG, 8 OHIG, 2 CRF, and 9 JADE) and 371 1-hour UT1 sessions (223 NEOS INT01, 101 INT02, and 47 INT03). We also submitted updated EOP files and daily Sinex solution files for all IVS sessions to the IVS Data Centers immediately following analysis. The GSFC VLBI Analysis Center provides a source position service as part of the RDV program. Observations of 64 requested sources were made in 2009 for members of the astronomy and astrometry community, and precise positions were obtained for most of them. The GSFC Analysis Center maintains a Web site at <http://lupus.gsfc.nasa.gov>.

### 2.2. Research Activities

The GSFC Analysis Center performs ongoing research aimed at improving the VLBI technique. Several of these research activities are described below:

- ICRF2: Members of the analysis group took a major role in the preparation of the Second Realization of the International Celestial Reference Frame (ICRF2). Most of the preparatory work was done at GSFC, including resolution of numerous source and session problems, designation of unstable sources, and evaluation of the effects of different time ranges, different session types, different solution types, gradients, pressure loading, the Vienna mapping function, and thermal deformation. Extensive decimation testing was done to determine a realistic noise floor. Also, systematic differences between preliminary catalogs from different

analysis centers were studied, in cooperation with S. Lytvyn (MAO/NASU, Kiev, Ukraine). The final underlying catalog solution was made at GSFC, as well as much of the writing of the IERS Technical Note [1]. The ICRF2 was adopted by the International Astronomical Union in August 2009 and became official on January 1, 2010.

- **R&D Intensives:** Four R&D sessions were devoted to studying alternative scheduling strategies for the UT1 Intensives. In each of these, the network was divided into two subnets, with Kokee and Wettzell scheduled as a series of 1-hour Intensives and the other stations as a regular R&D. The Intensives alternated between the current strategy, which uses a small list of strong sources, and an alternative strategy, which uses all mutually visible geodetic sources. Preliminary results indicate that the test strategy is more robust and has lower formal errors. We have requested time for four more such sessions in 2010.
- **Source Monitoring:** The source monitoring program continued, with the goal of observing all geodetic sources at least 12 times, and a set of other astrometric sources at least twice in any 12-month period. The latter list contains sources in the ICRF, as well as other sources of special interest. In 2009, 189 new sources were added to the geodetic catalog. The new sources generally have less structure, but are also weaker. At the beginning of 2009, there were 186 geodetic sources that did not meet the observing target, but by the end of 2009 this was reduced to 117.
- **VLBI/SLR Combination:** The traditional procedure used by the IERS for generating an ITRF is to combine the different technique solutions from each technique combination center. Alternatively, we would like to generate multi-technique solutions using the same software and a priori models. Eventually, we want to produce solutions combining all the geodetic techniques at the normal equation level using *GEODYN*. As a first step, we considered a VLBI-SLR combination solution. Doing VLBI-only solutions, we verified that *GEODYN* and *Calc/Solve* parameter estimates for 24-hour sessions agree at the one formal error level. We generated a VLBI/SLR solution for Earth orientation parameters using *GEODYN SOLVE* by combining VLBI and SLR normal equations. In future work, we will investigate the optimal strategy for combining VLBI and SLR normal equations, taking into account the problems of ground ties and technique weighting.
- **IYA2009 Session:** For the celebration of the International Year of Astronomy, GSFC scheduled the largest astrometric VLBI session ever attempted. This involved 34 globally distributed stations and used 243 of the 295 ICRF2 defining sources. Writing the schedule required modifying *Sked* to allow more stations, and similar changes will be needed to various *Calc/Solve* programs for analysis. This session is being correlated at the Haystack Correlator and will be analyzed at GSFC.
- **Atmospheric Pressure Loading:** We investigated the differences between applying atmospheric pressure loading corrections at the observation level versus applying 24-hour session average pressure loading corrections. It was found that observation level non-tidal pressure loading corrections do not reduce baseline length and UEN site coordinate RMS scatter by more than the 24-hour average corrections. However, NNT/NNR conditions must be applied if 24-hour corrections are used. The tidal components (S1 and S2) of pressure loading must still be applied at the observation level. We presented this work with T. van Dam at the Spring 2009 EGU meeting and are writing it up for publication.

- TRF2008: The GSFC group generated a solution for the ITRF2008 IVS combination solution, which was submitted to the IERS. New features included recently implemented *Solve* options to apply antenna thermal deformation and VMF1 mapping functions.
- Ny-Ålesund Site Motion: We completed work on a paper comparing site coordinate time series and velocity estimates from co-located VLBI, GPS, and DORIS antennas at Ny-Ålesund [2]. The main points of the paper are that the observed uplift is about twice that predicted from postglacial rebound and present day ice melting. GPS and VLBI vertical rates show an increase of 3-4 mm/yr between the rates measured before 2003 and the rates measured after 2003, indicating that ice melting estimates need to be revised.
- Source position time series: We began a study of source stability using source position time series. From methods developed by Martine Feissel-Vernier, the Allan variance is being used to determine the level and type of noise for each source. Information on the drift is also used to build a stability index. Stability indices were determined for different sets of time series from GSFC and Observatoire de Paris (OPAR). A new method was developed to classify sources into three categories: 1) showing a noise level (white noise) that is improving with time, 2) showing a threshold noise level (flicker noise) that has stabilized at a certain level, and 3) showing a disturbance due to some “signal” in the time series (structure, periodic signal, outliers, etc.). This study led to the development of a MATLAB software package to operationally analyze time series of VLBI source positions, using the Allan variance.
- Higher Frequency CRF: We continued working with associates at JPL, USNO, NRAO, and Bordeaux Observatory to extend the celestial reference frame to higher frequencies by using the VLBA at K and Q bands ( $\sim 24$  and  $\sim 43$  GHz). The primary goals are to build up a reference frame for use in planetary spacecraft navigation at Ka band ( $\sim 33$  GHz), and to build a reference frame less affected by source structure and potentially more precise than the current X/S frame. The K/Q group updated and re-submitted two papers on this work to the *Astronomical Journal* [3, 4]. Two additional K-band sessions were also analyzed.

### 2.3. Software Development

The GSFC group develops and maintains the *Calc/Solve* analysis system, a package of approximately 120 programs and 1.2 million lines of code. One significant addition was program *make\_vmf\_trp\_file*, which makes external VMF files for use in *Solve* analysis.

The current Mark III VLBI database system is over 30 years old and suffers from flexibility and portability issues. Therefore, we have begun development of a new VLBI data structure and a new analysis software package. The new data structure will use the NetCDF library to store observations and auxiliary data in binary files. The new data format will allow greater flexibility, space efficiency, and portability. The initial stage of the new software development process has been finished. All of the current features and abilities in *Calc/Solve* will be implemented in the new data analysis software, and it will be more flexible, efficient, and user friendly.

### 3. Staff

The Analysis Center staff consists of a GSFC civil servant, Dr. Chopo Ma, and six NVI, Inc. employees who work under contract to GSFC. Dr. Ma oversees the GSFC VLBI project for GSFC

and is also the IVS representative to the IERS, the current chair of the IERS Directing Board, and the chair of the IVS/IERS ICRF2 Working Group. Dr. John Gipson is the GSFC VLBI Project Manager and also the chair of IVS Working Group 4 on VLBI Data Structures. Dr. David Gordon and Dr. Daniel MacMillan lead contract tasks that support the Analysis Center. New members of the group include Dr. Sergei Bolotin, formerly of the Main Astronomical Observatory of the National Academy of Sciences of Ukraine, and Dr. Karine Le Bail. Table 1 lists the seven staff members and their main areas of activity.

Table 1. Staff members and their main areas of activity.

Ms. Karen Baver	Intensive analysis and monitoring, software development, Web site.
Dr. Sergei Bolotin	Database analysis, ICRF2, next generation software development.
Dr. John Gipson	Source monitoring, station dependent noise, parameter estimation, new data structure.
Dr. David Gordon	ICRF2, database analysis, RDV analysis, K/Q reference frame, <i>Calc</i> development, quarterly EOP/TRF updates.
Dr. Karine Le Bail	ICRF2 source stability studies.
Dr. Chopo Ma	ICRF2, CRF/TRF/EOP, K/Q reference frame.
Dr. Daniel MacMillan	ICRF2, CRF/TRF/EOP, mass loading, antenna deformation, apparent proper motion, VLBI2010 simulations, VLBI+SLR combination.

#### 4. Future Plans

Plans for the next year include: ICRF2 maintenance, participation in VLBI2010 development efforts, continued development of the new VLBI data structure and the new analysis software, participation in additional K/Q observations and high frequency reference frame development, and further research aimed at improving the VLBI technique.

#### References

- [1] “The Second Realization of the International Celestial Reference Frame by Very Long Baseline Interferometry”, A. Fey, D. Gordon, and C. Jacobs, editors, IERS Technical Note 35, 2009.
- [2] “The Kinematics of Ny-Ålesund from Space Geodetic Data”, H. Kierulf, B. Pettersen, D. MacMillan, and P. Willis, *Journal of Geodynamics*, 48, 37-46, July 2009.
- [3] “The Celestial Reference Frame at 24 and 43 GHz. I. Astrometry”, G. Lanyi, D. Boboltz, P. Charlot, A. Fey, E. Fomalont, B. Geldzahler, D. Gordon, C. Jacobs, C. Ma, C. Naudet, J. Romney, O. Sovers, and L. Zhang; submitted to *Astronomical Journal*.
- [4] “The Celestial Reference Frame at 24 and 43 GHz. II. Imaging”, P. Charlot, D. Boboltz, A. Fey, E. Fomalont, B. Geldzahler, D. Gordon, C. Jacobs, G. Lanyi, C. Ma, C. Naudet, J. Romney, O. Sovers, and L. Zhang; submitted to *Astronomical Journal*.
- [5] “Precise Geodesy with the Very Long Baseline Array”, L. Petrov, D. Gordon, J. Gipson, D. MacMillan, C. Ma, E. Fomalont, R. C. Walker, and C. Carabajal, *Journal of Geodesy*, 83, 859-876, 2009.

# Haystack Observatory Analysis Center

*Arthur Niell, Chris Beaudoin, Brian Corey*

## Abstract

Analysis activities at Haystack Observatory in 2009 were closely related to the technology development progress that is reported separately. Some of these efforts were:

- analysis of the expected efficiency of MV3
- analysis of the Eleven feed in a Dewar for optimum use on the Patriot 12-m antenna
- upgrade of the program *fourfit* to handle the broadband delay
- generation of Matlab scripts to duplicate much of the functionality of the post-correlation program *fourfit* for rapid modification and development of new modeling
- investigation of the impact of the phase variation due to changing differential linear polarization on the phase delay

## 1. Introduction

It is often difficult to separate analysis and hardware development. Here we report numerical calculations and software development related both to the technology development and to the observation program of the IVS. In this period the developments are entirely driven by the VLBI2010 program and the advances associated with the implementation of the broadband delay (BBD). The broadband delay is obtained by measuring the phase across four bands that will eventually span approximately 10 GHz, using the curvature to estimate the charged particle contribution. This is in contrast to the current determination of delay as the group delay across about 1 GHz at X-band, using S-band to provide the ionosphere correction.

The hardware development which has prompted the analysis effort reported here is the project that has installed proof-of-concept broadband systems on the 5-m MV3 antenna at GGAO, Greenbelt, Maryland, and on the 18-m antenna at Haystack Observatory, Westford, Massachusetts.

## 2. Analysis of the MV3 Efficiency

Antenna chamber measurements of the Lindgren feed, which is mounted on the 5-m MV3 antenna for the proof-of-concept broadband system, were combined with direct physical measurements of the sub-reflector and primary reflector shape of the MV3 antenna to better understand the efficiency and gain characteristics after the measured efficiency was found to be very low. Additionally, it did not seem possible to determine an optimum focus setting.

The problem was found to be a mis-match of the paraboloidal shape of the primary reflector and the shape of the sub-reflector, which is not hyperboloidal. One possible way to improve the efficiency is to make a new sub-reflector of the proper shape, but this was judged unnecessary since the new 12-m antenna was anticipated to be available in mid- to late 2009.

This study has led to understanding the low efficiency of the antenna that has been experienced with standard S/X observations over the entire history of the antenna's usage.

### 3. Analysis of the Optimum Dewar Design for the Patriot 12-m Antenna

A newly designed feed from Chalmers University, designated the Eleven feed, is expected to be used for VLBI2010. However, it is important to optimize the size of the Dewar that will house the Eleven feed on the 12-m antenna. To do this, the physical dimensions of the Eleven feed were used in combination with a proposed design of a Dewar/cryostat and with the specifications of the 12-m to determine the size of the Dewar that would minimize the blockage of the sub-reflector and maximize the efficiency of the antenna. Figure 1 displays the dependence of the Eleven antenna's feed efficiency on the cryostat radius and the cryostat wall length protruding above the top face of the feed.

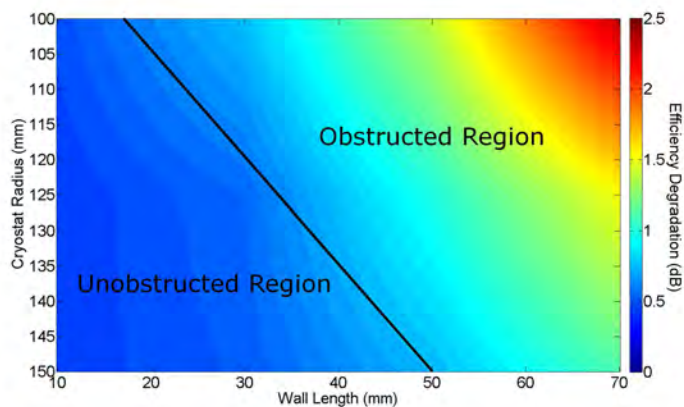

Figure 1. Feed efficiency dependence on cryostat size. The obstructed region is that in which the cylinder radius and length are such that the opening angle of the feed is obstructed by the cylinder wall in the geometric optics sense. The efficiency degradation increases from bottom left to top right.

### 4. Estimation of Broadband Delay Using *Fourfit* and Matlab Scripts

The program *fourfit*, which evolved from *frnge*, continues to be the program for obtaining the observables from the Mark IV correlator output. Up to now it has dealt only with a single band of data, such as S or X, and the calculation of the ionosphere corrected delay has been made at the following stage of analysis. To obtain the broadband delay, all four bands must be fit simultaneously in order to obtain the maximum signal-to-noise ratio. Furthermore, in some cases a source may not be detected in some band because of the low SNR in that band. To remedy this, *fourfit* has been enhanced to simultaneously fit multiple bands for amplitude, phase, delay, and rate. For the first time the contribution of the ionosphere to the phase can also be introduced in *fourfit* to accommodate the quadratic phase term introduced by charged particles along the signal path. Further improvements will allow the simultaneous estimation of the ionosphere difference contribution to the delay. Ultimately all polarizations will be combined in the estimation of the observables.

A MATLAB implementation of *fourfit*, which is written in C, has been developed specifically for rapid prototyping of VLBI2010 broadband fringe fitting algorithms. This software does not possess the full functionality of *fourfit* but does incorporate the identical fringe-search engine. The

MATLAB fringe fitting software has enabled the development of a new phase calibration correction algorithm that has been shown to align fringe phases across 2 GHz (4 contiguous 512 MHz bands) of analog bandwidth. Figure 2a shows the raw fringe phases obtained on the Westford to GGAO baseline while observing source 4C39.25, and Figure 2b shows the phase calibrated fringe phases. This result is a significant step towards realizing the goals of VLBI2010. It is expected that this algorithm will also allow fringe fitting of non-contiguous 512 MHz bands, and future broadband development observations will be conducted to test this expectation.

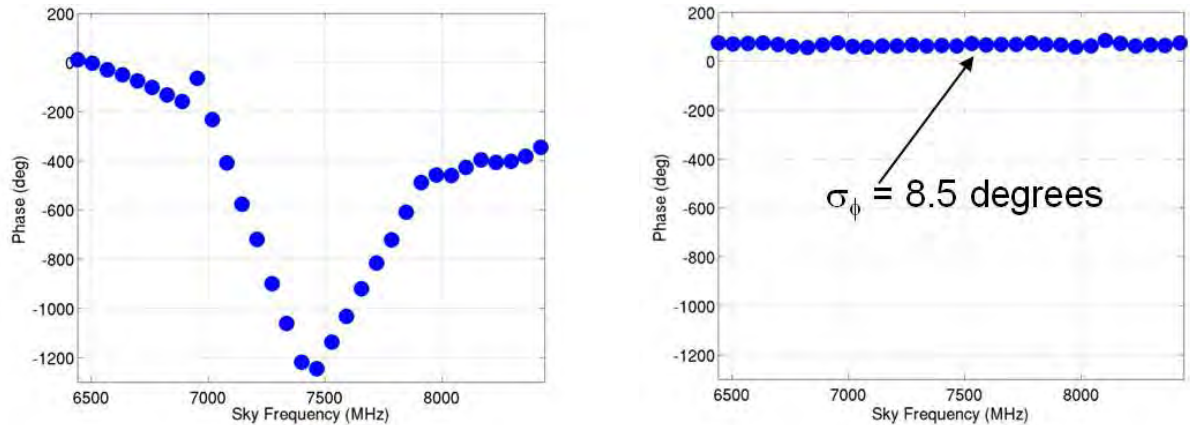

Figure 2. Cross correlation phase on Westford-MV3 baseline for a) raw fringe phases and b) phase-calibrated fringe phases.

## 5. Polarization

The feeds being developed for the VLBI2010 broadband delay system intrinsically produce linear polarization. As the antennas rotate to observe a common source from different parts of the world, the relative parallactic angles of the antennas will vary. In order to realize the maximum sensitivity it will be necessary to cross-correlate all possible polarization products.

To investigate the effect, observations were made of the source 4C39.25, which passes south of Westford and north of MV3. With this geometry the two antennas rotate in opposite directions as the source crosses the sky, and the relative parallactic angles change by  $180^\circ$ . The cross-correlation amplitudes for the 512 MHz band above 3.5 GHz are shown in Figure 3 for one of the parallel-hand and cross-hand polarization cross-correlations. (Due to intrinsic labeling in the post-correlation software, the vertical and horizontal polarizations are assigned to the circular polarization labels R and L.) The amplitudes of the 10 minute scans follow the pattern expected for the change in relative parallactic angle, although the magnitude of the cross-hands does not come up to that of the parallel hands as would be expected if the responses of both antennas were the same in both polarizations.

The two polarizations in each antenna are independent, so in principle two independent estimates of the delay are obtained for each scan. Furthermore the delay difference between the two polarizations should differ by a constant value after phase calibration. An active area of research is how to obtain the best estimate of the delay observable or observables from the linear polarizations.

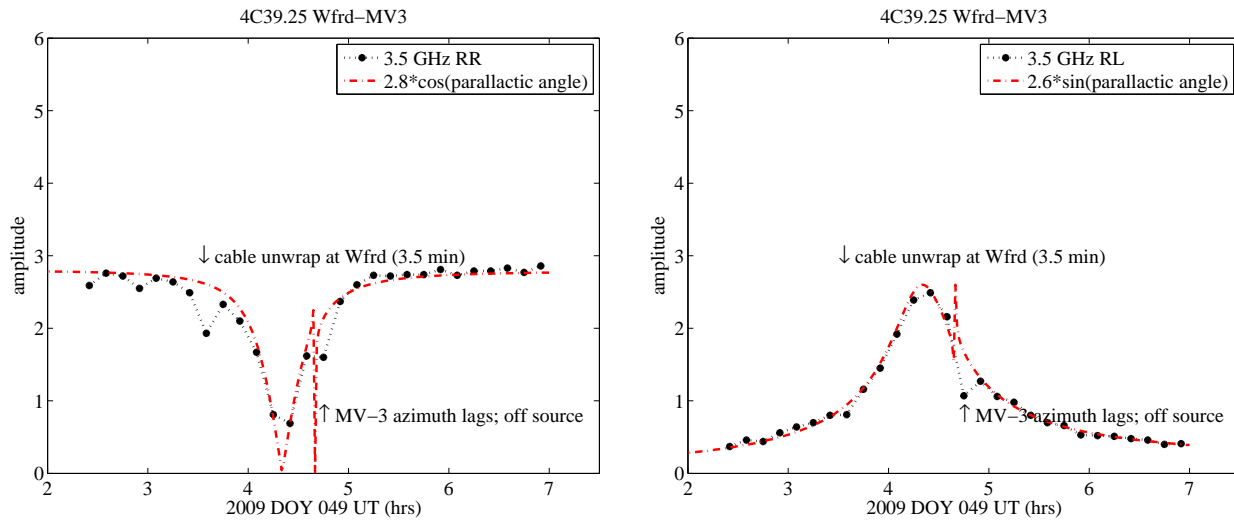

Figure 3. Amplitudes for the parallel-hand (RR) and cross-hand (RL) linear polarization correlations for the 3.5 GHz band.

An alternate approach that would avoid the problem of reduced cross-correlation amplitude for differential parallactic angles around  $90^\circ$  would be to produce circular polarization just following the feed (in the Dewar). This approach is being considered also, but calibration of the cross-polarization in each antenna is a concern.

## 6. Outlook

Efforts will continue to apply the analysis tools for optimizing the VLBI2010 observing system hardware and to develop algorithms for estimating the new observables to be obtained from the broadband equipment. Foremost will be how to make use of the multi-polarization observations in an optimal production mode.

Among the first observations with the new 12-m antenna waiting to be assembled at GGAO will be the sampling of sources with both simple and complex structure in order to assess the impact of source structure phase on the broadband delay. Previously at Haystack models were developed of the phase change with frequency and baseline of several sources by using the S/X structures and by making assumptions about the spectral characteristics of the components. More detailed modeling will be necessary to compare with observations when actual data become available.



# IAA VLBI Analysis Center Report 2009

*Elena Skurikhina, Sergey Kurdubov, Vadim Gubanov*

## Abstract

This report presents an overview of IAA VLBI Analysis Center activities during 2009 and the plans for the coming year.

## 1. General Information

The IAA IVS Analysis Center (IAA AC) is located at the Institute of Applied Astronomy of the Russian Academy of Sciences in St. Petersburg, Russia. The IAA AC contributes to IVS products, such as daily SINEX files, TRF, CRF, rapid and long-term series of EOP, baseline length, and tropospheric parameters. A source position catalog has been calculated within the scope of the IERS/IVS Working Group on the Second Realization of the ICRF. Several ways of source selection with NNR constraints were proposed and tested. EOP, UT1, and station positions were estimated from domestic observation programs Ru-E and Ru-U. The IAA AC generates NGS files.

## 2. Component Description

The IAA AC performs data processing of all kinds of VLBI observation sessions. For VLBI data analysis we use the QUASAR and the OCCAM/GROSS software packages. All reductions correspond to the IERS Conventions (2003). Both packages use NGS files as input data.

The IAA AC submits to the IVS Data Centers all kinds of products: daily SINEX files for EOP and EOP-rates and station position estimations, TRF, CRF, baseline length, and tropospheric parameters.

The QUASAR and the OCCAM/GROSS software packages are supported and developed. IVS NGS files are generated in automatic mode on a regular basis.

## 3. Staff

- Vadim Gubanov, Prof.: development of the QUASAR software and development of the methods of stochastic parameter estimation.
- Sergey Kurdubov, scientific researcher: development of the QUASAR software, global solution, and DSNX file calculation.
- Elena Skurikhina, Dr.: team coordinator, VLBI data processing, and OCCAM/GROSS software development.

## 4. Current Status and Activities

### • Software development for VLBI processing

The QUASAR software is being developed to provide contributions to IVS products. The software is capable of calculating all types of IVS products. A scale problem was fixed in the QUASAR software during 2009.

- **Global solution**

In 2009 two global solutions (iaa2008c and iaa2009a) using the QUASAR software were calculated and submitted to IVS. All available data for 1980–2009 (through the end of March 2009, a total of 6,353,387 delays) were processed. CRF was fixed by NNR constraints to 203 radiosources. TRF was fixed by NNR and NNT constraints to station positions and velocities of 11 stations: MATERA, KOKEE, WETTZELL, FORTLEZA, WESTFORD, ALGOPARK, NYALES20, NOTO, ONSALA60, LA-VLBA, and MK-VLBA. Stochastic signals were estimated by means of the least-squares collocation technique. The radio source coordinates, station coordinates, and velocities were estimated as global parameters. EOP, WZD (linear trend plus stochastic signal), troposphere gradients, and station clocks (quadratic trend plus stochastic signal) were estimated as arc parameters for each session.

3,165 global parameters have been estimated: 2,918 radio source positions, and the positions and the velocities of 141 VLBI stations (14 with discontinuities).

Global solution iaa2009a is different from the iaa2008c solution only in corrected (corresponding to the other ACs) relativistic formulae; as a result, the scale factor was improved.

- **Participation in the IERS/IVS Working Group on the Second Realization of the ICRF**

Global solutions with different sets of sources for NNR constraints were obtained. Transformation parameters between obtained source catalogs were calculated and compared.

A ranking method of source sets was suggested, in order to select the list of sources that better defines the orientation parameters of rigid rotation transformation from one system to another. Formal errors of the transformation parameters were selected as a characteristic of the source set.

- **Routine analysis**

The IAA AC submits daily SINEX files for the IVS-R1 and IVS-R4 sessions as rapid solution (iaa2008a.snx) and SINEX files based on all 24-hour experiments for the Quarterly Solution.

During 2009 the routine data processing was performed with the OCCAM/GROSS software using a Kalman Filter. The IAA AC operationally processed the “24h” and Intensive VLBI sessions. Submitting the results to the IERS and the IVS was performed on a regular basis. Processing of the Intensive sessions is fully automated. The EOP series iaa2007a.eops and iaa2005a.eopi, baseline lengths iaa2007a.bl, and troposphere parameters iaa2007a.trl were continued. At the moment, the EOPS series contains 3,718 estimates of pole coordinates, UT1, and celestial pole offsets, and the EOPI series contains 6,490 estimates of UT1. Long-time series of station coordinates, baseline lengths, and tropospheric parameters (ZTD, gradients) were computed with the station position catalog ITRF2005.

- **EOP parameter calculation from domestic QUASAR network observations**

Since February 2009 the QUASAR VLBI Network Svetloe—Zelenchukskaya—Badary has used the Mark 5B registration system for regular determination of Earth orientation parameters. Correlation is performed at the IAA correlator. The observations are carried out in the framework of two national programs: 24-hour sessions for the determination of five EOP parameters from the full network (Ru-E program) and one baseline 1-hour sessions for the determination of Universal Time on the Zelenchukskaya—Badary (or the Svetloe—Badary)

baseline (Ru-U program). Each of these two sessions is run twice per month. The mean RMS EOP deviations from the IERS 05C04 series in the Ru-E program are 1.03 mas for Pole position, 46 s for UT1-UTC, and 0.66 mas for Celestial Pole position for 46 sessions. The RMS deviation of the Universal Time values from the IERS C04 series for 73 sessions for the Ru-U program is 98  $\mu$ s. Since February 2009, a year of observations within the Russian Domestic programs was carried out using the Mark 5B registration system. For 14 sessions from the Ru-E program, the rms from the IERS 05C04 series is 1.12 mas for Pole position, 49  $\mu$ s for UT1-UTC, and 0.41 mas for Celestial Pole position. For 36 Ru-U Mark 5B sessions, the rms from the UT1 IERS 05C04 was 46  $\mu$ s. Station positions were specified in the ITRF2005 and VTRF2008 catalog systems for both domestic and IVS observations.

• **Antenna axis offset estimation from VLBI**

The antenna axis (AO) offsets were estimated from global solution and single sessions. We have built a set of global solutions from all available sessions and from a set of sessions between stations discontinuous in observations. We compared offsets estimated on different intervals for some stations which are discontinuous due to repair work. For the stations of the QUASAR network, we compared our estimations to local surveying data. For some stations the value of axis offset has been changed after repairs: at time spans

03.03.04 – 06.05.04:  $AO_{Svetloe} = -15.5 \pm 3.5$  (mm) (from local surveying: -12.5 (mm));  
 06.08.03 – 07.06.21:  $AO_{Svetloe} = -10.0 \pm 2.8$  (mm) (from local surveying:  $-7.5 \pm 0.5$  (mm)),  
 and 07.06.21 – 09.11.12:  $AO_{Svetloe} = 1.0 \pm 2.0$  (mm) (from local surveying:  $-3.0 \pm 1.5$  (mm)).

• **CONT08 data processing**

15 daily CONT08 sessions were united in one 15-day session and processed with OC-CAM/GROSS software. Pole position, UT1, WZD, and clock offsets were estimated as stochastic parameters with Kalman filter. EOP are modeled as a random walk dynamical process with an a-priori standard deviation of 1 mas and a Power Spectral density of ruled white noise of 0.000010  $as^2$  a day. The results of the comparison of Total Zenith Delay (TZD) to data calculated from GPS observations by CODE AC are presented in Figure 1 and in Table 1.

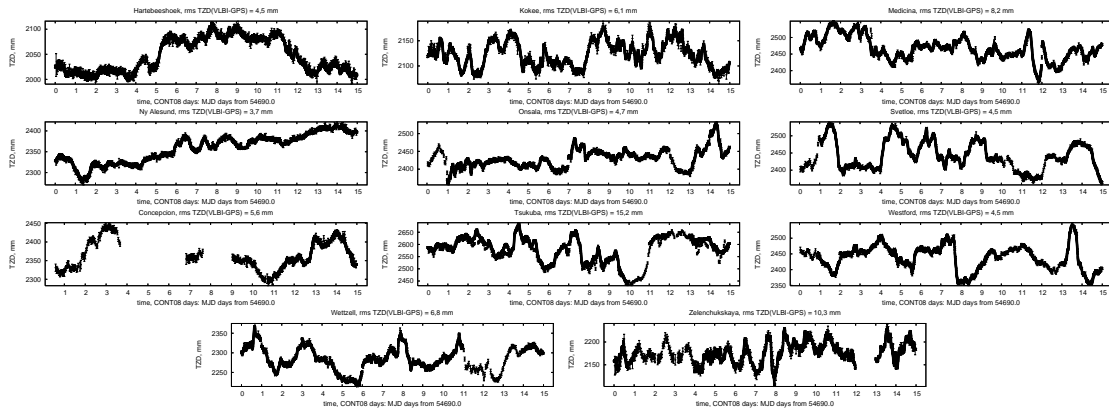

Figure 1. TZD from VLBI and GPS comparison

Table 1. CONT08: TZD comparison for VLBI and GPS

Station	Hh	Kk	Mc	Ny	On	Sv	Tc	Ts	Wf	Wz	Zc
bias, mm	1.9	0.1	-1.2	0.3	-1.1	-0.5	-0.2	-9.6	-1.8	2.5	0.9
rms, mm	4.4	6.1	8.1	3.5	4.3	4.2	5.7	11.0	6.6	5.4	9.9

Figure 2 presents 1-hour estimations of  $X_p$ ,  $Y_p$ , and UT1 relative to slowly varying daily a-priori series. The subdaily RMS residuals after removing the IERS Conventions (2003) model (for diurnal and sub-diurnal variations in polar motion caused by ocean tides and nutation terms with periods less than two days) are  $249 \mu\text{as}$  for  $X_p$ ,  $223 \mu\text{as}$  for  $Y_p$ , and  $15 \mu\text{s}$  for UT1.

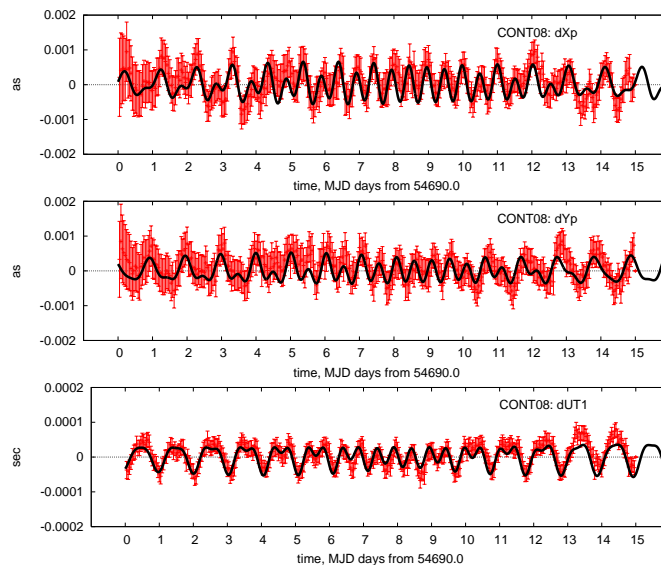

Figure 2. Subdaily estimates of EOP at 1-hour intervals compared to the IERS Conventions (2003) model of EOP diurnal and sub-diurnal variations (tidal plus nutation terms)

## 5. Future Plans

We plan to:

- Continue to submit all types of IVS product contributions.
- Continue investigations of VLBI estimation of EOP, station coordinates, and troposphere parameters, and comparison with satellite techniques.
- Calculate CRF and TRF from global solutions.
- Further improve algorithms and software for processing VLBI observations.

## Vienna IGG Special Analysis Center Annual Report 2009

*Harald Schuh, Johannes Böhm, Sigrid Böhm, Tobias Nilsson, Andrea Pany, Lucia Plank, Hana Spicakova, Kamil Teke, Jörg Wresnik*

### Abstract

The main activity of the VLBI group at the Institute of Geodesy and Geophysics (IGG) of Vienna University of Technology in 2009 has been the development of new VLBI software based on Matlab, called Vienna VLBI Software VieVS. Furthermore, studies related to VLBI2010 simulations, Earth rotation and geodynamical parameters from VLBI have been continued.

### 1. General Information

The Institute of Geodesy and Geophysics (IGG) is part of the Faculty of Mathematics and Geoinformation of the Vienna University of Technology. It is divided into three research units, one of them focusing on advanced geodesy (mathematical and physical geodesy, space geodesy). Within this research unit, one group (out of three) is dealing with geodetic VLBI.



Figure 1. Some members of the VLBI group at IGG at the EVGA Meeting 2009 in Bordeaux: Andrea Pany, Johannes Böhm, Harald Schuh, Lucia Plank, and Hana Spicakova.

### 2. Staff

Personnel at IGG associated with the IVS Special Analysis Center in Vienna are Harald Schuh (Head of IGG, Chair of the IVS Directing Board), and eight scientific staff members. Their main research fields are summarized in Table 1.

Table 1. Staff members ordered by their main focus of research.

Johannes Böhm	VLBI2010, Vienna VLBI Software (VieVS)
Andrea Pany	VLBI2010, troposphere, turbulence theory
Jörg Wresnik (until 08/2009)	VLBI2010, scheduling
Kamil Teke	VieVS, least squares adjustment
Lucia Plank	VieVS, Earth orientation
Hana Spicakova	VieVS, station displacements
Tobias Nilsson (from 05/2009)	VieVS, Earth orientation
Sigröd Böhm	Earth orientation, tidal influences

### 3. Current Status and Activities

- **Vienna VLBI Software VieVS**

A graphical user interface (GUI) in Matlab was added to VieVS to allow simple handling. Results of VieVS, in terms of baseline length repeatabilities, were compared to those of Occam 6.1. A comparison campaign was started with the goal of comparing different VLBI analysis software packages on the basis of the computed delay and its partial derivatives, in order to detect present inadequacies in the modeling part of the software packages.

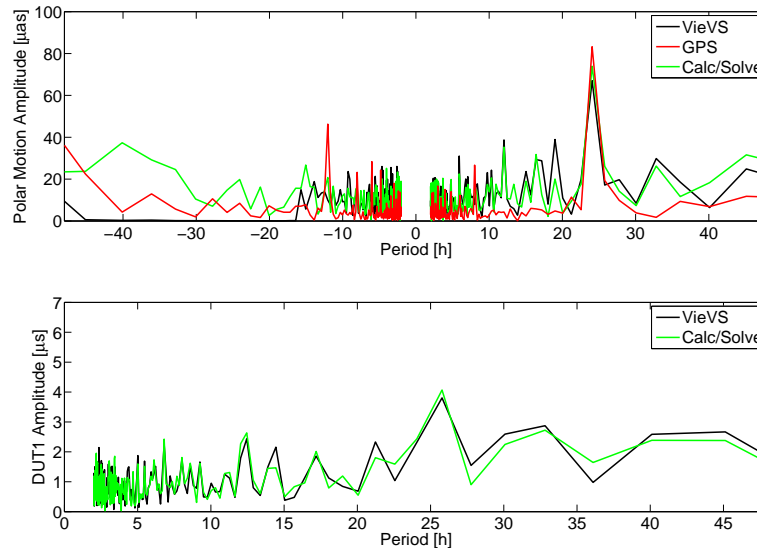

Figure 2. VieVS: Spectra of polar motion and DUT1 from the recent CONT08 campaign. For comparison, we show the spectra from another VLBI solution (made by Thomas Artz, Bonn using CALC/SOLVE) and from a GPS solution (made by Peter Steigenberger with Bernese).

- **Earth orientation parameters from VieVS and Occam 6.1**

We have used VieVS to estimate high frequency Earth rotation variations during the contin-

uous VLBI campaigns CONT02, CONT05, and CONT08. The results were then analyzed and compared to other solutions. As an example, in Figure 2 the spectra of polar motion and DUT1 from the recent CONT08 campaign are plotted. The spectra show the residual polar motion/DUT1 that remain after removing the interpolated C04 05 values as well as the IERS model for high frequency Earth rotation variations (McCarthy and Petit, 2004 [4]). As a comparison, we also show the spectra from another VLBI solution (made by Thomas Artz, Bonn using CALC/SOLVE) and from a GPS solution (Steigenberger et al., 2006 [6]). The two VLBI solutions agree very well, while there are some differences between the VLBI spectra and the GPS spectrum (e.g., there is a peak at 12 hours prograde for VLBI and not for GPS, while GPS has a peak at 12 hours retrograde instead). The reason for this needs further investigations.

In addition to the development of VieVS, the software package Occam 6.1 was used for processing VLBI observation data from 1984-2008, focusing on the derivation of Earth rotation parameters and in particular of DUT1 with sub-daily resolution (Englich et al., 2010 [1]). The estimated DUT1 series were investigated for tidal effects with periods shorter than 35 days. The comparison with DUT1 amplitudes of the conventional IERS models showed deviations in the diurnal and semi-diurnal tidal bands of up to 2.5 microseconds. The residuals in the semi-diurnal tidal band could be reduced almost to zero by accounting for the effect of the lunisolar torque on the triaxial Earth. Concerning the zonal tidal variations our study revealed significant discrepancies ( $> 40$  microseconds) between the observed variations and variations predicted by the conventional model in the fortnightly tidal band, which could be considerably reduced when a combined model as suggested by Gross (2009 [2]) was applied.

- **Love and Shida numbers**

A new module for global solutions is being added to VieVS which allows for the estimation of TRF/EOP/CRF as well as for the determination of geophysical parameters such as Love and Shida numbers and the Free Core Nutation period from solid Earth tidal deformations. First results are obtained from the IVS R1 and R4 sessions covering seven years, and they are shown in Figure 3.

- **Troposphere delays**

We used ray-traced delays computed with the Kashima Ray-tracing Tools (KARAT, Hobiger et al 2008 [3]) and high-resolution numerical weather models of the Japan Meteorological Agency for the VLBI site in Tsukuba during a 14-day typhoon period in September 2007 to explore possibilities of improving mapping functions and the modeling of the asymmetric part of the wet delays (Pany et al. 2009 [5]).

#### 4. Future Plans

In 2010 we will continue the development of the new VLBI software VieVS. This software will also include a tool for scheduling purposes. Additionally, we will contribute to the ongoing activities within VLBI2010, and we will carry out Earth orientation and reference system studies. W.r.t. troposphere delay modeling, we will test the impact of applying a priori correlations from turbulence theory to the analysis, and it is planned to equip VieVS with a Kalman Filter solution and simulation tools.

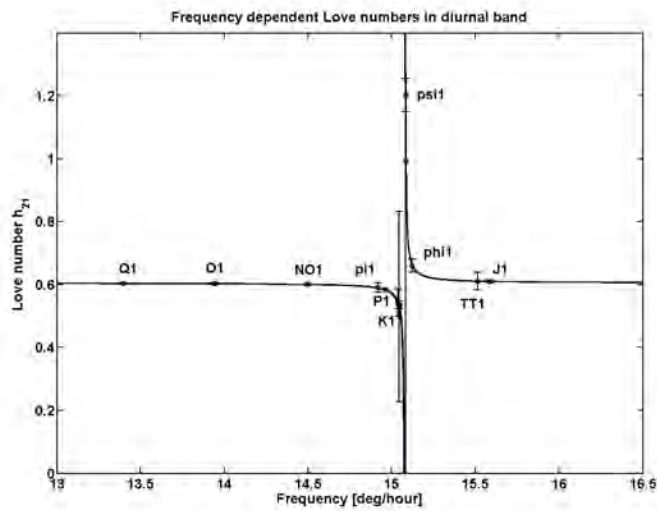

Figure 3. Love numbers: Estimation of frequency-dependent Love numbers in the diurnal band.

## 5. Acknowledgements

We are very grateful to the Austrian Science Fund (FWF) for supporting our work by the research projects P18404-N10 ('VLBI2010') and P21049-N14 ('SCHEDE2010'). We also acknowledge the Austrian Academy of Sciences for funding project 22353 and the German Research foundation (DFG) for funding project SPEED (SCHU 1103/3-1).

## References

- [1] Engligh, S., H. Schuh, R. Weber, Short-term tidal variations in UT1: compliance between modelling and observation, in: Highlights of Astronomy, Vol. 15, ed. by I.F. Corbett, 2010.
- [2] Gross, R., Ocean tidal effects on Earth rotation, Journal of Geodynamics, Vol. 48(3-5):219-225, 2009.
- [3] Hobiger, T., R. Ichikawa, T. Kondo, Y. Koyama, Fast and accurate ray-tracing algorithms for real-time space geodetic applications using numerical weather models, J. Geophys. Res. 113, D20302, 2008.
- [4] McCarthy, D., G. Petit (eds.), IERS Conventions (2003), IERS Technical Note No. 32, Verlag des Bundesamtes für Kartographie und Geodäsie, Frankfurt am Main, 2004.
- [5] Pany, A., J. Böhm, H. Schuh, T. Hobiger, R. Ichikawa, Modeling azimuthal asymmetries of the troposphere delay during a 14-days typhoon period in Tsukuba, Proceedings of the 19th European VLBI for Geodesy and Astrometry Working Meeting, 24-25 March 2009, edited by G. Bourda, P. Charlot, and A. Collioud, 2009.
- [6] Steigenberger, P., M. Rothacher, R. Dietrich, M. Fritsche, A. Rülke, S. Vey, Reprocessing of a global GPS network, J. Geophys. Res., Vol. 111, B05402, 2006.



# Italy INAF Analysis Center Report

*M. Negusini, P. Sarti, C. Abbondanza*

## Abstract

This report summarizes the activity of the Italian INAF VLBI Analysis Center. Our Analysis Center is located in Bologna, Italy and belongs to the Institute of Radioastronomy, which is part of the National Institute of Astrophysics. IRA runs the observatories of Medicina and Noto, where two 32-m VLBI AZ-EL telescopes are situated. This report contains the AC's VLBI data analysis activities and briefly outlines the investigations carried out at Medicina and Noto concerning gravitational deformation of the VLBI telescopes.

## 1. Current Status and Activity

Investigations into VLBI local tie surveying and antenna deformation continued in 2009. On the operational side, a new GPS survey of the antenna reference point was carried out at the Medicina observatory in late June. On the computational side, the deformation patterns of the structure had been determined in previous years, and a complete signal path variation (SPV) model could be defined for the Medicina telescope (see [1] and [2]). The same procedure adopted for Medicina was applied successfully at Noto: the combination of terrestrial surveying methods also allowed the definition of an SPV model. Particular care was taken to accurately compute the coefficients of the linear combinations that determine SPV [3]. The two models were used to correct the VLBI delay in routine geodetic VLBI data analysis. Results clearly show that reference point height depends on elevation-dependent signal path variations, the latter being induced by gravitational deformations [4]. The height shift of the antenna reference point in Medicina is 8.9 mm; and it is 6.7 mm at Noto, much larger than the VLBI position formal errors. This bias cannot be determined by relying on VLBI data alone, as its effect is fully incorporated into the estimated station height and antenna axis offset [4].

## 2. Data Analysis and Results

The IRA started to analyze VLBI geodetic databases in 1989, using a CALC/SOLVE package on the HP1000 at the Medicina station. In subsequent years, the same software was installed first on an HP360 workstation and later on an HP715/50 workstation. In more recent years, two HP785/B2600 workstations and an HP282 workstation were used. In 2007, a new Linux workstation was set up for the migration of all the VLBI data analysis, and Mark 5 Calc/Solve was installed. During 2009, we stored all the 1999-2009 databases available on the IVS data centers. All the databases were processed and saved with the best selection of parameters for the final arc solutions. The most recent IRA solution for crustal deformation comprises all the VLBI sessions analyzed at IRA from 1987 to 2008, and the estimated horizontal and vertical velocities are presented in [5].

Our Analysis Center has participated in the IVS TROP Project on Tropospheric Parameters since its beginning. Tropospheric parameters (wet and total zenith delay and horizontal gradients) of all IVS-R1 and IVS-R4 24-hour VLBI sessions were submitted regularly in the form of SINEX files. During the past year, we started again to regularly submit our results. We have also computed and submitted a long time-series of troposphere parameters using all VLBI sessions available in

our catalog in order to estimate the variations over time of the content of water vapor in the atmosphere.

### 3. Outlook

For the time being, our catalog finally contains all available experiments. In 2010, using our new Linux workstation and the up-to-date Mark 5 Calc/Solve software, we plan to analyze all available databases, thus completing the catalog. We will continue with the regular submission of INAF tropospheric parameters to the IVS data centers.

### References

- [1] Sarti, P., C. Abbondanza, L. Vittuari (2009). Gravity dependent signal path variation in a large VLBI telescope modelled with a combination of surveying methods. *J Geodesy* 83(11):1115-1126.
- [2] Sarti, P., L. Vittuari, C. Abbondanza (2009) Laser scanner and terrestrial surveying applied to gravitational deformation monitoring of large VLBI telescope's primary reflectors, *J Surv Eng* 135(4):136-148.
- [3] Abbondanza, C., P. Sarti. Effects of illumination functions on the computation of gravity-dependent signal path variation models in Cassegrainian VLBI telescopes. *J Geodesy* (*submitted*)
- [4] Sarti P., C. Abbondanza, L. Petrov, M. Negusini. Height bias and scale effect induced by antenna gravity deformations in geodetic VLBI data analysis. *J Geodesy* (*submitted*)
- [5] Negusini, M., P. Sarti, C. Abbondanza (2009). Geodetic research at IRA-INAf: recent results between a golden past and a gloomy future. In: Proceedings of the 19th European VLBI for Geodesy and Astrometry Working Meeting, 92-96.

# JPL VLBI Analysis Center Report for 2009

*Chris Jacobs*

## Abstract

This report describes the activities of the JPL VLBI Analysis Center for the year 2009. We continue to do celestial reference frame, terrestrial reference frame, earth orientation, and spacecraft navigation work using the VLBI technique. There are several areas of our work that are undergoing active development. An important development was moving measurements to higher data rates with our earth orientation work going to 448 Mbps and our reference frame work to 224 Mbps. Our international collaboration to build celestial frames at K- (24 GHz) and Q-bands (43 GHz) matured to roughly part-per-billion (ppb) accuracy. Our in-house work to build a reference at X/Ka-bands (8.4/32 GHz) is also close to ppb accuracy. We supported several missions with VLBI navigation measurements. We continue to study ways to improve spacecraft tracking using VLBI techniques.

## 1. General Information

The Jet Propulsion Laboratory (JPL) Analysis Center is located in Pasadena, California. Like the rest of JPL, the center is operated by the California Institute of Technology under contract to NASA. JPL has had a VLBI analysis group since about 1970. Our work is focused on supporting spacecraft navigation. This includes several components:

1. Celestial Reference Frame (CRF) and Terrestrial Reference Frame (TRF) are efforts that provide infrastructure to support spacecraft navigation and Earth orientation measurements.
2. Time and Earth Motion Precision Observations (TEMPO) measures Earth orientation parameters based on single baseline semi-monthly measurements. These VLBI measurements are then combined with daily GPS measurements, as well as other sources of Earth orientation information. The combined product is used to provide Earth orientation for spacecraft navigation use.
3. Delta differenced one-way range ( $\Delta$ DOR) is a differential VLBI technique that measures the angle between a spacecraft and an angularly nearby extragalactic radio source. This technique thus complements the radial information from spacecraft doppler and range measurements by providing plane-of-sky information for the spacecraft trajectory.
4.  $\Delta$ VLBI phase referencing using the VLBA to measure spacecraft positions.

## 2. Technical Capabilities

The JPL Analysis Center acquires its own data and supplements it with data from other centers. The data we acquire is taken using NASA's Deep Space Network (DSN).

1. Antennas: Most of our work uses 34-m antennas located near Goldstone (California, USA), Madrid (Spain), and Tidbinbilla (Australia). These include the following Deep Space Stations

(DSS): the “High Efficiency” subnet comprised of DSS 15, DSS 45, and DSS 65 (see Figure 1) which has been the most often used set of antennas for VLBI. More recently, we have been using the DSN’s beam waveguide (BWG) antennas: DSS 13, DSS 24, DSS 25, DSS 26, DSS 34, DSS 54, and DSS 55. Less frequent use is made of the DSN’s 70-m network (DSS 14, DSS 43, and DSS 63). Typical X-band system temperatures are 35K on the HEF antennas. The 70-m and BWGs are about 20K. Antenna efficiencies are typically well above 50% at X-band.

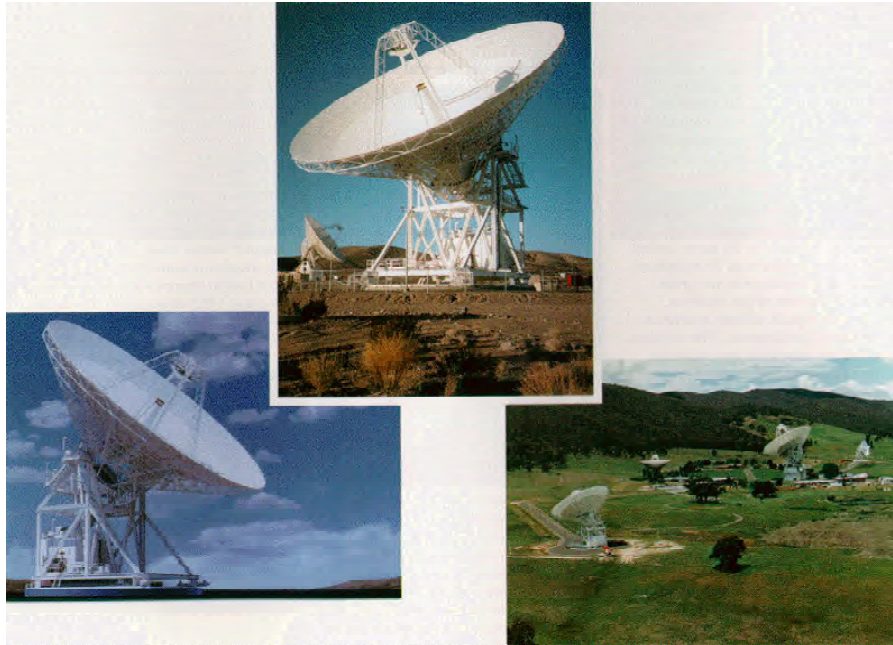

Figure 1. This figure shows the three high-efficiency antennas in the subnet: Goldstone is in the center; Robledo, Spain is on the lower left; and Tidbinbilla, Australia is on the lower right. These antennas were designed to have an optimum efficiency at X-band (8.4 GHz), which was to become the standard downlink frequency for solar-system exploration. An important secondary objective was to have a reasonable efficiency at Ka-band (32 GHz) thereby allowing for possible future use at the next highest band allocated for deep space communications. The subnet was completed in 1986 in time for the Voyager encounter with Uranus.

2. Data acquisition: We use the Mark 5A VLBI data acquisition systems. In addition, we have JPL-unique systems called the VLBI Science Recorder (VSR) and the Wideband VSRs (WVSR) which have digital baseband converters and record directly to hard disk. The data is later transferred via network to JPL for correlation with our software correlator.
3. Correlators: JPL VLBI Correlation systems are now exclusively based on the SOFTC software, which handles the  $\Delta$ DOR, TEMPO, and CRF correlations of disk format recordings. The VSRs and the software correlator have also been used for connected element interferometry tests of antenna arraying concepts.
4. Solution types: We run several different types of solutions. For  $\Delta$ DOR spacecraft tracking we make narrow field ( $\approx 10^\circ$ ) differential solutions. The TEMPO solutions typically have a

highly constrained terrestrial (TRF) and celestial frame (CRF) as a foundation for estimating Earth orientation parameters. These reference frames are produced from global solutions which then provide the framework needed for use by TEMPO and  $\Delta$ DOR.

### 3. Staff

Our staff are listed below with a brief indication of areas of concentration within the VLBI effort at JPL. Note that not all of the staff listed work on VLBI exclusively, as our group is involved in a number of projects in addition to our VLBI work.

- Durgadas Bagri: VLBI instrumental calibrations and TEMPO.
- Jim Border:  $\Delta$ DOR spacecraft tracking.
- Mike Heflin:  $\Delta$ DOR, CRF, and TRF. Maintains MODEST analysis code.
- Chris Jacobs: S/X, K, Q, X/Ka CRFs, and TRF.
- Peter Kroger:  $\Delta$ DOR spacecraft tracking.
- Gabor Lanyi: VLBA phase referencing,  $\Delta$ DOR, WVR, K-Q CRF, and TRF.
- Steve Lowe: Software correlator, fringe fitting software.
- Walid Majid:  $\Delta$ DOR, VLBA phase referencing.
- Chuck Naudet: WVR, Mark 5A support, and K-Q CRF.
- Lyle Skjerve: Field support of VLBI experiments at Goldstone.
- Ojars Sovers: S/X, K, Q, and X/Ka CRFs and TRF. Maintains MODEST analysis code.
- Alan Steppe: TEMPO and TRF.
- L. D. Zhang: S/X, K & Q CRFs, and TEMPO.

### 4. Current Status and Activities

In order to support the DSN's move to Ka-band (32 GHz), JPL is leading a collaboration with the Goddard Space Flight Center, the U.S. Naval Observatory, the National Radio Astronomical Observatory, and the Bordeaux Observatory to extend the ICRF to K-band (24 GHz) and Q-band (43 GHz). Results were presented by Fomalont & Jacobs (2009) and Jacobs et al. (2009). In-house work to build an X/Ka-band CRF was presented by Jacobs & Sovers (2009). Research on phase referencing for spacecraft navigation was done by Bagri & Majid (2009) and Majid, Fomalont, & Bagri (2009). We were also involved in the work which led to the acceptance of the ICRF2 by the IAU (Ma et al., 2009).

During 2009 we demonstrated that data taken at the maximum Mark 5A rate of 1024 Mbps could be processed by our software correlator. This data rate opens the door for a very high sensitivity VLBI system when combined with the large apertures and low system temperatures of the DSN's antennas.

In recent years our Delta-DOR spacecraft tracking team has provided direct measurements of spacecraft angular position to support navigation of the Phoenix landing on Mars, the Messenger flybys of Mercury, and the Dawn flyby of Mars, and it is now supporting Earth return navigation for the Hayabusa mission (Border, 2009).

## 5. Future Plans

In 2010, we expect to improve TEMPO by increasing data rates to 896 Mbps and reference frame VLBI to 448 Mbps—assuming that resources for recording media are approved. We plan to turn our proto-type Ka-band phase calibrator into a set of operational units for operational deployment in late 2010. Work on the Digital Back End (DBE) will continue. Our next generation fringe fitting program is also expected to come online in the next year. We anticipate refereed publications on our high frequency celestial reference frame work. We plan to contribute to a refereed publication describing the ICRF2. On the spacecraft front, we plan to continue supporting a number of operational missions while further improving techniques for using VLBI for spacecraft tracking.

## 6. Acknowledgements

The work described here was in part performed at the Jet Propulsion Laboratory, California Institute of Technology, under contract with the National Aeronautics and Space Administration. Copyright 2010 California Institute of Technology. Government sponsorship acknowledged.

## References

- [1] D. Bagri, W. Majid, ‘Accurate Spacecraft Angular Position from DSN VLBI Phases using X-Band Telemetry or DOR Tones,’ IEEE Aerospace Conference, Big Sky, MT, 7–14 Mar 2009.  
doi: 10.1109/AERO.2009.4839367 [ieeexplore.ieee.org/stamp/stamp.jsp?arnumber=04839367](http://ieeexplore.ieee.org/stamp/stamp.jsp?arnumber=04839367)
- [2] J. S. Border, ‘Innovations in Delta Differential One-way Range: From Viking to Mars Science Laboratory,’ Proc. 21st Int. Symposium on Space Flight Dynamics, Toulouse, France, 28 Sep 2009.
- [3] E.B. Fomalont, and C.S. Jacobs, ‘Extending the ICRF to Higher Radio Frequencies: 24, 32, 43 GHz Global Astrometry,’ Meeting of the Division of Dynamical Astronomy, Virginia, Beach, 05 May 2009.  
[www.astro.iag.usp.br/~sylvio/dda2009.html](http://www.astro.iag.usp.br/~sylvio/dda2009.html)
- [4] E.B. Fomalont, S. Kopeikin, G. Lanyi, and J. Benson, ‘Progress in Measurements of the Gravitational Bending of Radio Waves using the VLBA,’ ApJ, 699, pp. 1395-1402, 10 July 2009.  
doi: 10.1088/0004-637X/699/2/1395 [www.iop.org/ej/abstract/0004-637x/699/2/1395](http://www.iop.org/ej/abstract/0004-637x/699/2/1395)
- [5] C.S. Jacobs, and O.J. Sovers, ‘Extending the ICRF to Higher Radio Frequencies: X/Ka (8.4/32 GHz) Global Astrometry,’ Proc. 19th European VLBI for Geodesy & Astrometry Working Meeting, G. Bourda, P. Charlot, A. Collioud, eds., pp. 9–13, Bordeaux, France, 24 March 2009.  
[www.u-bordeaux1.fr/vlbi2009//travaux/article/84\\_Jacobs%20CS.pdf](http://www.u-bordeaux1.fr/vlbi2009//travaux/article/84_Jacobs%20CS.pdf)  
[www.u-bordeaux1.fr/vlbi2009/index.php?numpage=13&nompage=Proceedings](http://www.u-bordeaux1.fr/vlbi2009/index.php?numpage=13&nompage=Proceedings)
- [6] C.S. Jacobs and the KQ VLBI Collaboration, ‘Extending the ICRF to Higher Radio Frequencies: 24, 32, 43 GHz Global Astrometry,’ New Science Enabled by Microarcsecond Astrometry, Socorro, New Mexico, 23 July 2009. [www.aoc.nrao.edu/events/astrometry/files/Jacobs-KKaQ-090723.ppt](http://www.aoc.nrao.edu/events/astrometry/files/Jacobs-KKaQ-090723.ppt)
- [7] C. Ma, et al, ‘IERS Technical Note No. 35: 2nd Realization of the ICRF by VLBI,’ eds. A. Fey, D. Gordon, & C. Jacobs, IERS, BKG, Frankfurt am Main, Germany, Oct. 2009.  
[www.iers.org/nn\\_11216/IERS/EN/Publications/TechnicalNotes/tn35.html](http://www.iers.org/nn_11216/IERS/EN/Publications/TechnicalNotes/tn35.html)
- [8] W. Majid, E. Fomalont, D. Bagri, ‘Compactness of Weak Radio Sources at High Frequencies,’ *Approaching Micro-Asec. Resolution with VSOP-2: Astrophys. & Tech.*, ASP Conf. Ser. 402, Aug 2009.  
[aspbooks.org/custom/publications/paper/402-0448.html](http://aspbooks.org/custom/publications/paper/402-0448.html)

# KASI Combination Center Report

*Younghee Kwak, Jungho Cho*

## Abstract

This report introduces the activities of the Korea Astronomy and Space Science Institute (KASI) as an IVS Combination Center and shows preliminary combination results. We adopted ADDNEQ2, which is a subprogram of the Bernese GPS software, to stack the normal equations and to estimate the parameters. We also modified the program to apply it to the VLBI daily SINEX format. Our preliminary results, combined station coordinate residuals with respect to the individual solutions of Analysis Centers, show mm to cm-level accuracy. Starting in the second half of 2010, we will provide our official combination products.

## 1. General Information

KASI was accepted as an IVS Combination Center on October 21, 2008. The KASI Headquarters is located in the Daeduk Research and Development Complex, Daejeon. The space geodesy research of KASI was started in 1992 with GPS. Currently, the KASI Space Geodesy Research Group mainly works on the application and the combination of space geodetic techniques.

## 2. Component Description

The mission of the KASI Combination Center is:

- to create high quality combination products
- to control the quality of the Analysis Centers' results
- to provide feedback to the Analysis Centers
- to adhere to the IERS Conventions

## 3. Staff

Table 1. Personnel at the KASI Combination Center

Jungho Cho	+82-42-865-3234	jojh@kasi.re.kr
Younghee Kwak	+82-42-865-2031	bgirl02@kasi.re.kr

## 4. Current Status and Activities

(1) Analysis S/W

For combination analysis, we use the Bernese S/W which is a GPS data processing program. SNX2NQ0 and ADDNEQ2, subprograms of the Bernese S/W, are mainly used. The inputs to the

Bernese S/W are the N.E. (Normal Equation) Matrix and the N.E. vector from every daily SINEX file of the individual ACs since we adopted the Normal Equation level combination. First, the input SINEX files are converted to Normal Equation format (\*.NQ0) by the SNX2NQ0 program. The processing flow is described in Figure 1. The output is a daily SINEX file with combined station coordinates and EOP.

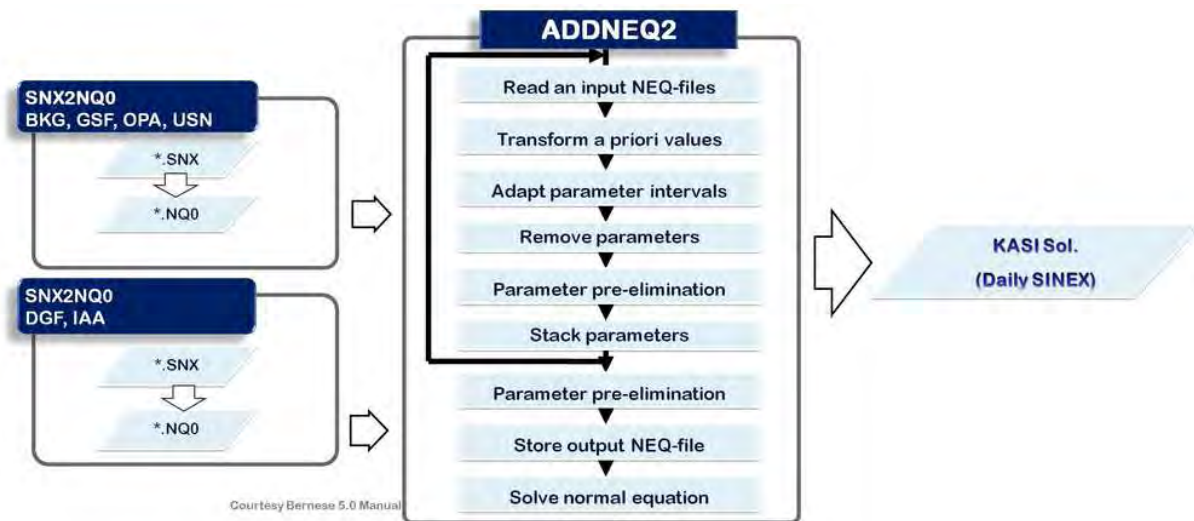

Figure 1. Combination processing flow

## (2) Preliminary Results

We combined the individual solutions of four ACs—BKG, GSFC, OPA, and USNO—for six sessions during January 2008. We could not combine the solutions of DGF and IAA because the daily SINEX files of DGF and IAA need additional processing to be converted to NQ0 format. Figures 2, 3, and 4 show the residuals of the combined station coordinates with respect to the individual solutions, and Figures 5 and 6 show the residuals of combined EOP with respect to the individual solutions.

## 5. Future Plans

First of all, we will continue verifying the Bernese S/W using each solution of the individual ACs one by one, since some of the earth orientation parameters (EOP) look biased. After verification of the Bernese S/W, we will produce NQ0 format files for DGF and IAA to combine all of the ACs' products. We will also establish the automated combination processing with the Bernese Processing Engine (BPE). This automated processing will produce an IVS combination solution for the whole period (1984 to present) easily and rapidly.



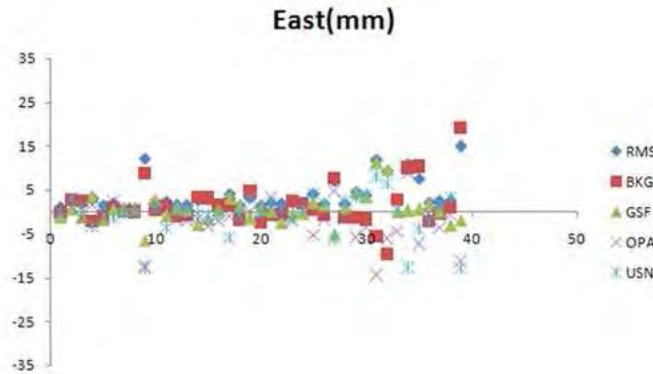

Figure 2. Residuals of East component

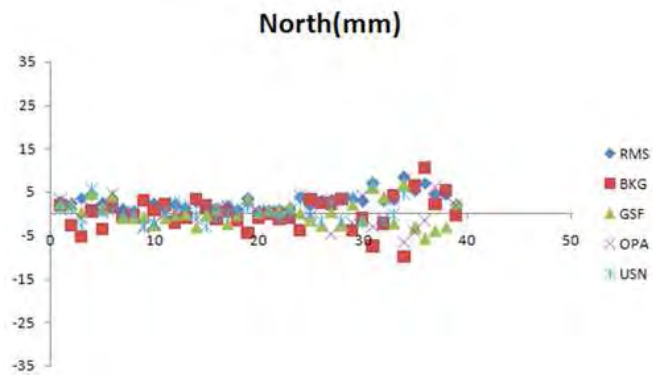

Figure 3. Residuals of North component

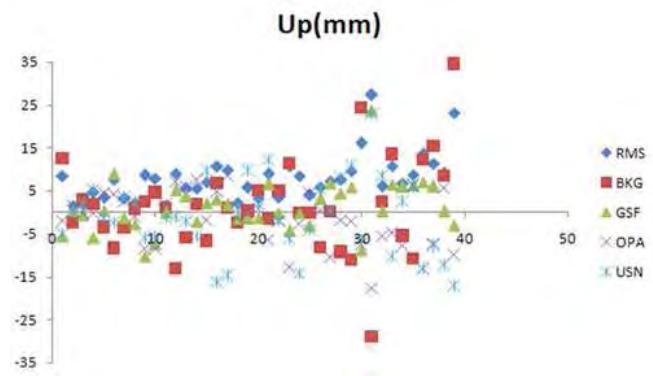

Figure 4. Residuals of Up component

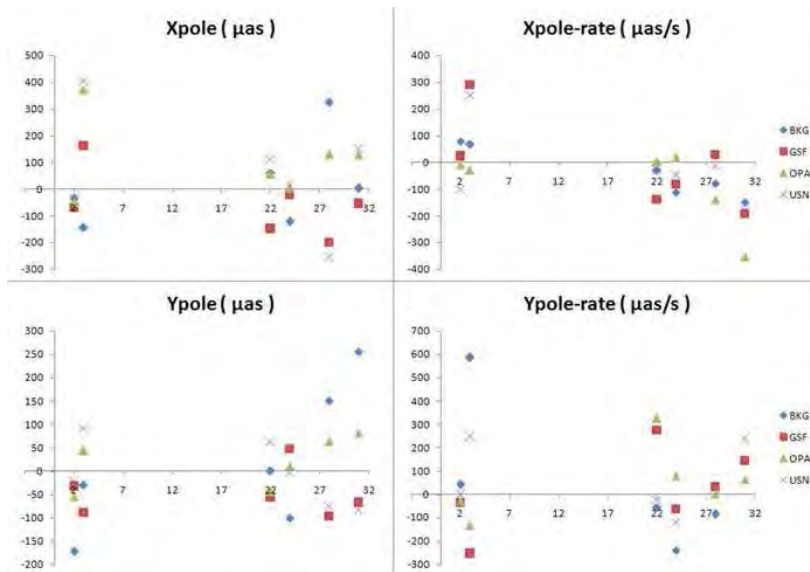

Figure 5. Residuals of X-pole, Y-pole, and their rates

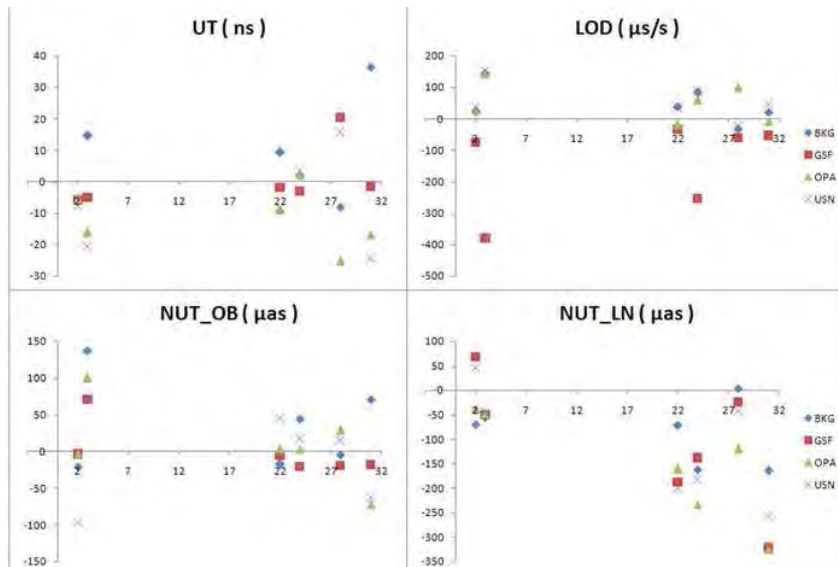

Figure 6. Residuals of UT1, LOD, and Nutation

# KTU-GEOD IVS Analysis Center Annual Report 2009

*Emine Tanır*

## Abstract

This report summarizes the establishment process of the KTU-GEOD IVS Analysis Center (AC) and its foreseen scientific activities. Beginning from 23<sup>rd</sup> of March 2009, the date the IVS Directing Board approved our application for establishing an AC named as KTU-GEOD in Turkey, we equipped our office with two workstations, one server, and one printer. All office supplies and hardware are bought from the budget of Karadeniz Technical University (KTU). KTU-GEOD will be maintained from now on at the department of Geomatics Engineering of KTU which is located in a city on the Black Sea coast of north-eastern Turkey, Trabzon. Being aware of the responsibilities of maintaining an IVS AC, we will strive to do our best in order to answer some of the expected IVS scientific requirements.

## 1. General Information

The proposal of Karadeniz Technical University (KTU) to become an International VLBI Service for Geodesy and Astrometry Analysis Center (IVS AC) [1] was accepted on March 23, 2009 in a Directing Board meeting during the 19<sup>th</sup> European VLBI for Geodesy and Astrometry Working Meeting held in Bordeaux, France.



Figure 1. Emine Tanır while working in the office of KTU-GEOD IVS AC

KTU-GEOD IVS AC will be financed and operated by the department of Geomatics Engineering, KTU. Following the approval of being an IVS AC, we gave an oral presentation at the 4<sup>th</sup> National Engineering Surveying Symposium, which took place at KTU during the days between 14-16 October 2009, concerning the establishment process of KTU-GEOD and its future visions in terms of possible contributions to the IVS [2]. All necessary hardware equipment (two workstations, one server, and one printer) accompanying the MATLAB compiler were provided by the

University budget. Our department provided a separate laboratory room for us to conduct our investigations within the IVS umbrella (see Figure (1)). So far the OCCAM *v.6.0* [4] VLBI analysis software has been used by myself, especially for my PhD. studies. From now on, besides OCCAM, we plan to use the Vienna VLBI Software (VieVS) [3] which is developed by the members of the VLBI group of the Institute of Geodesy and Geophysics (IGG), Vienna University of Technology (TU Wien).

## 2. Staff at KTU-GEOD Contributing to the IVS Analysis Center

- Dr. Emine Tanir, responsible for KTU-GEOD (primary scientific/technical contact).

## 3. Future Plans

In the future, the KTU-GEOD IVS AC plans to use VieVS, which is distributed with its open source code based on Matlab. With accompanying graphical user interfaces and batch process options for single- and multiple-sessions, VieVS is fully compatible with the Windows and Linux Operating Systems. It is compact and easy to use. We are anticipating the release of a geodetic parameter combination module of VieVS. We plan to analyze VLBI sessions with different parameterizations, focusing on the European VLBI Network (EVN). Analysis of EVN sessions is one of our specific interests. In 2010, we plan to study different stochastic models by means of comparing geodetic estimates derived from the analysis of VLBI sessions and from other space geodetic techniques. We would like to highlight that we need your support. Our contribution as an Analysis Center will not be able to be realized without the support of the IVS members and its collaborators.

## 4. Acknowledgements

We are grateful to Prof. Dr. Harald Schuh who has supervised and supported our studies from the very beginning of our PhD.. We are thankful to all the governing board of IVS.

## References

- [1] Schlüter, W., D. Behrend, The International VLBI Service for Geodesy and Astrometry (IVS): current capabilities and future prospects, *Journal of Geodesy*, Vol. 81, Nos. 6–8, pp. 379–387, June 2007. DOI 10.1007/s00190-006-0131-z.
- [2] Tanır, E., K. Teke, J. Böhm, and H. Schuh, Contribution of Geodetic VLBI Studies to IERS Products and Functions of KTU GEOD IVS Analysis Center, In: *4<sup>th</sup> National Engineering Surveying Symposium Proceedings Book*, Karadeniz Technical University, 134–164, 14-16 October 2009 (in Turkish).
- [3] Böhm, J., H. Spicakova, L. Plank, K. Teke, A. Pany, J. Wresnik, S. English, T. Nilsson, H. Schuh, T. Hobiger, R. Ichikawa, Y. Koyama, T. Gotoh, T. Kubooka, and T. Otsubo, Plans for the Vienna VLBI Software VieVS, In: *Proceedings of the 19th European VLBI for Geodesy and Astrometry Working Meeting*, G. Bourda, P. Charlot and A. Collioud (eds.), 24 - 25 March, 2009.
- [4] Titov, O., V. Tesmer, and J. Böhm, OCCAM *v. 6.0* software for VLBI data analysis, In: *International VLBI Service for Geodesy and Astrometry 2004 General Meeting Proceedings*, NASA/CP-2004-212255, N. R. Vandenberg and K. D. Baver (eds.), 2004.

# IVS Analysis Center at Main Astronomical Observatory of National Academy of Sciences of Ukraine

*Svitlana Lytvyn, Yaroslav Yatskiv*

## Abstract

This report summarizes the activities of the VLBI Analysis Center at the Main Astronomical Observatory of the National Academy of Sciences of Ukraine in 2009.

## 1. Introduction

The VLBI Analysis Center was established in 1994 by the Main Astronomical Observatory (MAO) of the National Academy of Sciences of Ukraine (NASU) as a working group of the Department of Space Geodynamics of the MAO. In 1998 the group started its IVS membership as an IVS Analysis Center. The MAO AC is located at the office building of the observatory in Kiev.

## 2. Technical Description

VLBI data analysis at the center is performed on two computers: an Intel Core 2 Duo 3.1 GHz box with 4 Gb RAM and a 1 TB HDD, and a Pentium-4 3.4 GHz box with 1 GB RAM and two 200 GB HDDs. Both computers are running under the Linux/GNU Operating System.

The Main Astronomical Observatory improved its Internet connection in 2009. Now we have a 100 Mbps fiber channel with a 256 Kbps backup on a leased line.

For data analysis we use the STEELBREEZE software which was developed at the MAO NASU. The STEELBREEZE software is written in the C++ programming language and uses the Qt 2.x widget library. STEELBREEZE makes Least Squares estimation of different geodynamical parameters with the Square Root Information Filter (SRIF) algorithm (see [1]).

The software analyzes VLBI data (time delays) of a single session or a set of multiple sessions. The time delay is modeled according to the IERS Conventions (2003) [2], as well as by using additional models (tectonic plate motion, nutation models, wet and hydrostatic zenith delays, mapping functions, etc.). The following parameters are estimated: Earth orientation parameters, coordinates and velocities of a selected set of stations, coordinates of a selected set of radio sources, clock function, and wet zenith delay.

## 3. Staff

The VLBI Analysis Center at Main Astronomical Observatory consists of three members:

**Yaroslav Yatskiv:** Head of the Department of Space Geodynamics; general coordination and support of activity of the Center.

**Svitlana Lytvyn:** Junior research scientist of the Department of Space Geodynamics; investigates the stability of VLBI-derived celestial and terrestrial systems.

**Sergei Bolotin:** Senior research scientist of the Department of Space Geodynamics; responsible for the software development and data processing. Sergei took an active part in the work of

the MAO AC in January—May. Since June he has advised us about the technical aspects of VLBI data analysis.

#### 4. Current Status and Activities in 2009

In 2009 we performed regular VLBI data analysis to determine Earth orientation parameters. “Operational” solutions were produced and submitted to the IVS on a weekly basis. The IERS Conventions (2003) [2] models were applied in the analysis. In the solutions, station coordinates and Earth orientation parameters were estimated.

Also, this year we continued to participate in the IVS Tropospheric Parameters project. Estimated wet and total zenith delays for each station were submitted to IVS. The analysis procedure was similar to the one used for the operational solutions.

The MAO AC participated in the IVS activities concerning ICRF2 preparation. In the frame of the IVS working group (WG) for ICRF2 we produced time series of radio source positions. Also, two global solutions, mao008a and mao006a (with and without VCS sessions), were obtained and provided to the ICRF2 WG.

The combined catalog maoC08a was created using all solutions submitted by various IVS analysis centers (individual solutions: aus007a, bkg001a, gsf007b, iaa008c, mao008a, opa008b and usn010b).

Some activities were directed to porting the STEELBREEZE software to the Qt3 library. The first, preliminary STEELBREEZE release, which can be compiled using the Qt-3.8.8 library, was issued.

#### 5. Plans for 2010

The MAO Analysis Center will continue to participate in operational EOP determination, as well as in updating the TRF and CRF solutions from VLBI analysis of the full data set of observations. We also plan to create a stable STEELBREEZE release based on Qt3 and to start to port this software to Qt4.

#### Acknowledgments

The work of our Analysis Center would be impossible without the activities of other components of IVS. We are grateful to all contributors from the Service.

#### References

- [1] Biermann, G.J., 1977, Factorization Methods for Discrete Sequential Estimation, V128, Mathematics in Science and Engineering Series, Academic Press.
- [2] IERS Conventions (2003), IERS Technical Note 32, eds. D.D. McCarthy and G. Petit, Bundesamt für Kartographie und Geodäsie, Frankfurt am Main.

# Analysis Center at National Institute of Information and Communications Technology

*Thomas Hobiger, Hiroshi Takiguchi, Ryuichi Ichikawa, Mamoru Sekido, Yasuhiro Koyama, Tetsuro Kondo*

## Abstract

This report summarizes the activities of the Analysis Center at National Institute of Information and Communications Technology (NICT) for the year 2009.

## 1. General Information

The NICT Analysis Center is located in Kashima, Ibaraki, Japan and is operated by the space-time standards group of NICT. Analysis of VLBI experiments and related study fields at NICT are mainly concentrated on experimental campaigns for developing new techniques such as e-VLBI for real-time EOP determination, prototyping of a compact VLBI system, time and frequency transfer, atmospheric path delay studies, and improvement of the accuracy of space geodetic techniques.

## 2. Staff

Members who are contributing to the Analysis Center at the NICT are listed below (in alphabetical order, with their working locations in parentheses):

- HOBIGER Thomas (Koganei, Tokyo), Atmospheric and ionosphere research using VLBI and GPS, studies on the improvement of the accuracy of space geodetic techniques
- ICHIKAWA Ryuichi (Kashima), Compact VLBI system development and Atmospheric Modeling
- KONDO Tetsuro (Kashima and Ajou Univ., Korea), Software Correlator
- KOYAMA Yasuhiro (Koganei, Tokyo), International e-VLBI
- SEKIDO Mamoru (Kashima), International e-VLBI and VLBI for spacecraft navigation
- TAKIGUCHI Hiroshi (Kashima), Time-transfer experiments, international e-VLBI, and loading effects

## 3. Current Status and Activities

### 3.1. Time and Frequency Transfer via VLBI

As a new frequency transfer technique, which enables the comparison of highly stable frequency standards, we proposed the geodetic VLBI technique using our MARBLE system. We carried out inter-comparison experiments between VLBI, GPS, and DMTD (Dual Mixer Time Difference) on the local Kashima-34-m—Kashima-11-m baseline in order to show that VLBI is able to measure the correct time difference. The experiment included proof of the clock difference measurement capability, whereby the length of a reference signal transmission cable was artificially changed by using a line stretcher. Usually, geodetic VLBI alternately observes multiple sources that are

uniformly covering the sky. Moreover, usually clock and atmosphere parameters as well as station coordinates are estimated within the geodetic analysis. However in this experiment, as we observed only one source and due to the short baseline, we estimated only clock parameters. The results reveal that the artificial delay changes measured by VLBI and DMTD show good agreement (within 10 ps). In general the VLBI results match the DMTD results better than GPS does. From this experiment, we confirmed the capability of the geodetic VLBI technique for time transfer application [8]. Further investigations of this application will be carried out.

### 3.2. Ultra-rapid UT1 Experiments

Data transfer via Internet protocols allows reduction of the latency of UT1 measurements obtained from VLBI. Such experiments, known as e-VLBI, were conducted in cooperation with colleagues from Metsähovi, Onsala, Wettzell, and GSI in order to demonstrate that the estimates of UT1 can be obtained shortly after the last scan has been observed [7]. By the usage of the UDP-based Tsunami protocol, data were sent to Kashima, converted to K5 format, and handed over to our software correlator, which is operated in distributed computing mode. In cooperation with Geographical Survey Institute (GSI) it was possible to obtain UT1 estimates, which have been proven to be as accurate as the IERS Bulletin-A results, as soon as four minutes after the last observation was made. Additionally application of real-time data transfer for 24-hour VLBI experiments has been tested on the Tsukuba—Onsala baseline. The experience gained from these experiments is going to be applied to the weekly Intensive VLBI sessions and is expected to improve the latency and accuracy of the IERS products.

### 3.3. MARBLE

We are developing a compact VLBI system with a 1.6 m diameter aperture dish in order to provide reference baseline lengths for calibration. We named the system “Multiple Antenna Radio-interferometry for Baseline Length Evaluation (MARBLE)” [4]. On December 9, 2008, we installed the first prototype of the compact VLBI system on the top of the building near the Kashima 34 m antenna and successfully detected the first fringe between the first prototype of the compact VLBI system and the Kashima 34 m on February 9, 2009 [5]. Moreover, we performed the first VLBI geodetic experiment between the first prototype and the Tsukuba 32 m of GSI on June 25, 2009. In this experiment, data acquisition at the Kashima 11 m was also performed. We estimated the baseline length between the first prototype and the Kashima 11 m (about 194 m) using the indirect method (see ‘MARBLE concept [5]’). The formal error of its estimation is about 23% smaller than that of the conventional estimation. At the end of 2009, we installed the second prototype of the compact VLBI system and performed a geodetic experiment with the first prototype and the Tsukuba 32 m on December 23, 2009. We are now processing the obtained data sets.

### 3.4. Ray-traced Troposphere Slant Delay Correction

As numerical weather models have been constantly improved with respect to their accuracy and resolution, it became feasible to utilize them for the purpose of computing troposphere delay corrections from ray-tracing [3], considering that residual delays are still estimated within the geodetic adjustment process. A software package, named Kashima Ray-tracing Tools (KARAT), has been developed with the ability to transform numerical weather model data sets to geodetic



reference frames, compute fast and accurate ray-traced slant delays [2], and correct geodetic data on the observation level. The impact of such corrections on UT1 estimates has been investigated by Boehm et al.[1] and is displayed in Figure 1.

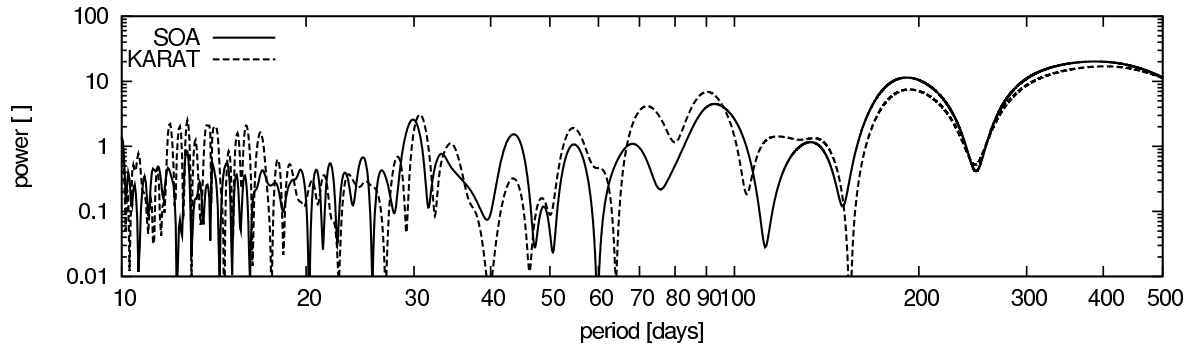

Figure 1. Lomb-Scargle periodogram of INT2 UT1 estimates w.r.t. IERS 05 C04 obtained from state-of-the-art (SOA, solid line) processing and after ray-traced corrections have been applied to station Tsukuba. The power at about fortnightly periods is clearly increased using the delays from direct ray-tracing with KARAT (dashed line). Details of this study can be found in Boehm et al.[1].

### 3.5. Kashima Ray-tracing Service - KARATS

In order to enable users of space geodetic techniques to take advantage of KARAT without the need to access numerical weather models on their own, it was decided to provide ray-tracing as a service. Thus the ray-tracing tools will be embedded in an automatic processing chain, called Kashima Ray-Tracing Service (KARATS), which can be started via a Webinterface. Once a user has taken his observations, he can send the data in a common format via the Internet to KARATS. Thereafter the Web server will do a rough data check and compute the geometry from the observation file. As soon as a ray-tracing client becomes available it will send the geometry file to that machine. The client performs the ray-tracing and sends the tropospheric delays back to the server. Thereafter the ray-traced delays are subtracted from the user's data and a "reduced" observation file is sent back to the user. KARATS is free of charge and can be accessed via <http://vps.nict.go.jp/karats/>. Although currently only GPS corrections can be computed online, VLBI is expected to be supported within 2010.

### 3.6. Development of a Multi-technique Space Geodetic Analysis Software Package

An analysis software package based on Java and named CONCERTO [6] enabled the user to consistently process SLR, GPS, and other satellite tracking data. The next version of this program package will also include VLBI as an additional space geodetic technique. As the software is currently being redesigned and completely re-written in C++, the requirements for complete VLBI data analysis (i.e. from ambiguity resolution through parameter estimation) can be taken into account. Considering the demand of VLBI2010, a focus will be set on automated and unattended processing of observations, which has been already implemented for SLR. A variety of observation formats, including raw correlator output, is supported by the VLBI module of C5++, allowing

consistent processing of VLBI data. Since CONCERTO was originally designed for satellite techniques, existing modules and models can also be utilized to do spacecraft tracking either by VLBI or by a combination of several techniques, which monitor the satellite.

#### 4. Future Plans

For the year 2010 the plans of the Analysis Center at NICT include:

- Further time and frequency transfer experiments
- Development of a multi-technique space geodetic analysis software, allowing automated and unattended processing of VLBI experiments
- Improvement of processing speed and efficiency for VLBI data correlation using multi-processors/multi-cores and high-speed networks
- International and domestic VLBI experiments for real-time EOP determination using e-VLBI and the K5 system
- Differential VLBI experiments for spacecraft tracking and its analysis

#### References

- [1] Boehm J., T. Hobiger, R. Ichikawa, T. Kondo, Y. Koyama, A. Pany, H. Schuh and K. Teke, Neutral atmosphere delays and UT1 determination from VLBI Intensive sessions, submitted to Journal of Geodesy, 2010.
- [2] Hobiger T., R. Ichikawa, Y. Koyama and T. Kondo, Fast and accurate ray-tracing algorithms for real-time space geodetic applications using numerical weather models, J. Geophys. Res., 113, D20302, 2008.
- [3] Hobiger T., R. Ichikawa, T. Takasu, Y. Koyama and T. Kondo, Ray-traced troposphere slant delays for precise point positioning, Earth, Planets and Space, 60(5), e1-e4, 2008.
- [4] Ichikawa R., A. Ishii, H. Takiguchi, H. Kuboki, M. Kimura, J. Nakajima, Y. Koyama, T. Kondo, M. Machida, S. Kurihara, K. Kokado, and S. Matsuzaka, Development of a Compact VLBI System for Providing over 10-km Baseline Calibration, "Measuring The Future", Proc. of the Fifth IVS General Meeting, 400-404, 2008.
- [5] Ichikawa R., A. Ishii, H. Takiguchi, Y. Koyama, T. Kondo, K. Kokado, S. Kurihara, and S. Matsuzaka, Present Status and Outlook of Compact VLBI System Development for Providing over 10 km Baseline Calibration, IVS NICT-TDC News, No. 30, 22-25, October 2009.
- [6] Otsubo T., H. Kunimori, B. Engelkemier, and F. Takahashi, Error control of numerical integration in SLR analysis software CONCERTO, Journal of the Geodetic Society of Japan, 40, 4, 347-355, 1994.
- [7] Sekido M., H. Takiguchi, Y. Koyama, T. Kondo, R. Haas, J. Wagner, J. Ritakari, S. Kurihara and K. Kokado, Ultra-rapid UT1 measurements by e-VLBI, Earth, Planets and Space, 60(8), 865-870, 2008
- [8] Takiguchi H., Y. Koyama, R. Ichikawa, T. Gotoh, A. Ishii, T. Hobiger and M. Hosokawa, VLBI Measurements for Frequency Transfer, Highlights of Astronomy, Volume 15, XXVIIth IAU General Assembly, August 2009, Ian F Corbett, ed.

# Paris Observatory Analysis Center OPAR: Report on Activities, January - December 2009

*Anne-Marie Gontier, Sébastien B. Lambert, Christophe Barache*

## Abstract

We report on activities of the Paris Observatory VLBI analysis center (OPAR) for calendar year 2009 concerning the development of operational tasks, the OPAR Web site, and research.

## 1. Developments at OPAR

### 1.1. Operational Status

OPAR personnel routinely analyzed diurnal (IVS rapid turnaround R1 and R4) sessions since 1979 (solution 2009a). Unconstrained normal equations of diurnal sessions were sent to the IVS in SINEX format for combination in the framework of the IVS analysis coordinator's task.

Late in 2009, an operational solution (2009i) analyzing Intensive sessions after 2006 was submitted to the IVS together with corresponding SINEX files.

Two reanalyses of diurnal sessions were done (2009a and 2009b), and the resulting EOP series and radio source catalogs were sent to the IVS.

Station and radio source coordinate time series were also produced and updated regularly.

Operational analysis of both diurnal and Intensive sessions will be continued in 2010. All the above products, except SINEX files, were also published on the OPAR Web site at <http://ivsopar.obspm.fr>.

### 1.2. Web Site and Virtual Observatory

The reader is referred to the IVS 2008 Annual Report for explanations about the Virtual Observatory (VO) activities at OPAR. In 2009, we developed the interface between the OPAR Web site and a number of astronomy and astrometry databases (e.g., NASA/NED, BVID, CDS, and the MOJAVE database at Purdue University, IN). The visitor is allowed to get information about radio sources observed during the analyzed VLBI sessions, including an optical view using the French Aladin software package.

### 1.3. Working Groups

OPAR members are involved in various working groups. A.-M. Gontier is a member of the IVS WG 4 and of the IAG WG 1.4.1. S. B. Lambert is the chair of the IAG WG 1.4.3. Both were members of the IVS/IERS WG on the Second Realization of the ICRF.

## 2. Research Activities Involving OPAR

### 2.1. Finalizing the ICRF2

We actively participated in the analyses for the IVS/IERS WG on the Second Realization of the ICRF. Especially, during the final phase of the frame construction, A.M. Gontier, S. B.

Lambert, and P. Charlot selected the 295 defining sources on the basis of coordinate time series derived by D. Gordon and structure indices produced by P. Charlot. The alignment of the ICRF2 catalog onto the ICRS was done as well by A.M. Gontier, E. F. Arias (BIPM), and S. B. Lambert, following a method developed and tested at the Observatoire de Paris. The details of the analyses and their results were reported as chapters of the IERS Technical Note 35 (Fey et al. 2009).

## 2.2. The Large Quasar Astrometric Catalog (LQAC)

The very large and increasing number of quasars reckoned from various sky surveys leads to a large quantity of data which brings various and inhomogeneous information in the fields of astrometry, photometry, radioastronomy, and spectroscopy. In [2], we described a work that aims at making available a general compilation of the largest number of recorded quasars obtained from all the available catalogs, with their best position estimates, and providing physical information at both optical and radio wavelengths. Thus, we constructed a catalog compilation giving coordinates, multiband photometry, radio fluxes, redshift, luminosity distances, and absolute magnitudes. We gathered the 12 largest quasar catalogs (four from radio interferometry programs and eight from optical surveys), and we carried out systematic cross-identifications of the objects. Information concerning *ubvgrizJK* photometry as well as redshift and radio fluxes at 1.4 GHz, 2.3 GHz, 5.0 GHz, 8.4 GHz, and 24 GHz were given when available. A small proportion of remaining objects, not present in the 12 catalogs but included in the Véron-Cetty & Véron quasar catalogs, are added to the compilation.

The LQAC contains 113,666 quasars. We discussed the external homogeneity of the data by comparing the coordinates, the redshifts, and the magnitudes of objects belonging to different catalogs. We used up-to-date cosmological parameters as well as recent models for galactic extinction and K-correction in order to evaluate the absolute magnitudes of the objects. In 2010, we foresee publishing an update of the present version, including the ICRF2.

## References

- [1] Fey, A. L., Gordon, D., & Jacobs, C. S. (Eds.) 2009, The Second Realization of the International Celestial Reference Frame by Very Long Baseline Interferometry, IERS TN 35, in print
- [2] Souchay, J., Andrei, A. H., Barache, C., et al. 2009, The construction of the large quasar astrometric catalog (LQAC), *A&A*, 494, 799

# Onsala Space Observatory – IVS Analysis Center

*Rüdiger Haas, Gunnar Elgered, Hans-Georg Scherneck, Tobias Nilsson<sup>1</sup>*

## Abstract

We briefly summarize the activities of the IVS Analysis Center at the Onsala Space Observatory during 2009 and give examples of results of ongoing work.

## 1. Introduction

We concentrate on a number of research topics that are relevant for space geodesy and geosciences. These research topics are addressed in connection to data observed with geodetic VLBI and complementary techniques.

## 2. Simulations for VLBI2010: Assessment of Atmospheric Turbulence for VLBI

During 2009 we continued to contribute to the simulations for the VLBI2010 project [1] and to the VLBI2010 design [2]. Using simulated and observed data from CONT05 and CONT08, we assessed the importance of atmospheric turbulence for geodetic VLBI [3], [4]. For this purpose, we used a method to simulate wet delays in a turbulent atmosphere [5], [6]. Seven different sets of turbulence parameters  $C_n^2$  were used for these simulations, including standard  $C_n^2$  values from literature (simulations S-1 and S-2),  $C_n^2$  values derived from high-resolution radiosonde profiles (S-3 to S-5), and  $C_n^2$  values derived from GPS observations at the CONT08 stations (S-6 and S-7). Clock errors were simulated as the sum of a random walk process, an integrated random walk process, and an integrated integrated random walk process. The observation noise was simulated as white noise with a standard deviation of 30 ps.

We analyzed the simulated and the observed data sets with the CALC/SOLVE software [7] using an identical analysis strategy. Radio source positions, polar motion, and the earth rotation angle were fixed to a priori values. The earth rotation rate and nutation offsets were estimated as daily parameters. Station positions were estimated for all participating stations, applying no-net-translation and no-net-rotation conditions. Clock and atmosphere parameters were estimated as piece-wise linear functions with an interval length of 20 minutes, and horizontal gradients were estimated every 6 hours. Figure 1 shows the repeatabilities of the three dimensional station position grouped according to the analysis. Results from the analysis of the seven simulated data sets (S-1 to S-7) and the observed data (Ref) are presented.

The study shows that atmospheric turbulence is the major error source for geodetic VLBI today. It also shows that the best agreement with the observations are obtained for the simulations using  $C_n^2$  obtained from the variance of the zenith total delay estimated from GPS data (S-6 and S-7).

---

<sup>1</sup>since May 1st, 2009, at Technical University of Vienna, Austria

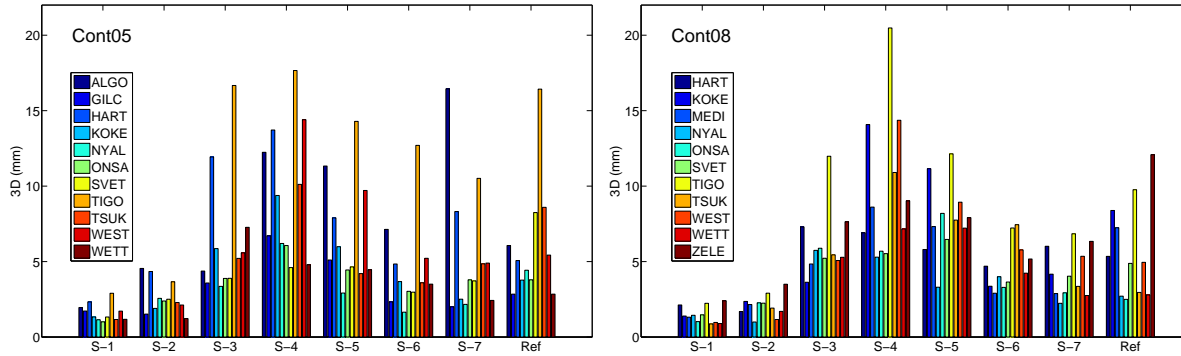

Figure 1. Repeatabilities of the three dimensional station positions grouped according to the analysis (simulations S-1 to S-7 and reference solution Ref) for CONT05 (left) and CONT08 (right). The participating stations are shown with shaded bars in the order listed in the key. Be aware that the shades of gray are different for CONT05 and CONT08.

### 3. Simulations for VLBI2010: Impact of Telescope Slew Rates

We studied the impact of the telescope slew rates on the geodetic results if a new and fast radio telescope is added to the existing VLBI network of rather slow telescopes [8]. In principle, faster slew rates do improve the accuracy of, for example, the derived station coordinates. However, fast slew rates also mean increased mechanical stress for the telescope. Furthermore, we show that by adding a fast telescope to a network of slower telescopes, the amount of idle time increases. A good balance between increased accuracy for the geodetic results and increased mechanical stress has to be found. This means that it might be advantageous to control and successively adapt telescope slew rates of newly added fast telescopes in the transition from today’s VLBI network to the future VLBI2010 network.

### 4. An Assessment of Long Time Series of Atmospheric Water Vapor Content

During 2009 we assessed the possibility of validating long time series of the atmospheric water vapor [9]. An overall motivation was to determine the relationship—and its uncertainties—between trends in the atmospheric water vapor and trends in the ground temperature. For this study we used one decade of data from GPS and VLBI observed at the Onsala Space Observatory, and additionally radiosonde (RS) data from the Gothenburg-Landvetter Airport, covering November 1996 to November 2006. Figure 2 shows the corresponding time series of the equivalent zenith wet delay.

The results show that the three data sets give comparable accuracy for time series of atmospheric water vapor. However, we also find that the frequency of VLBI experiments observed at the Onsala Space Observatory is too low to validate estimated linear trends using data acquired over a ten year period.

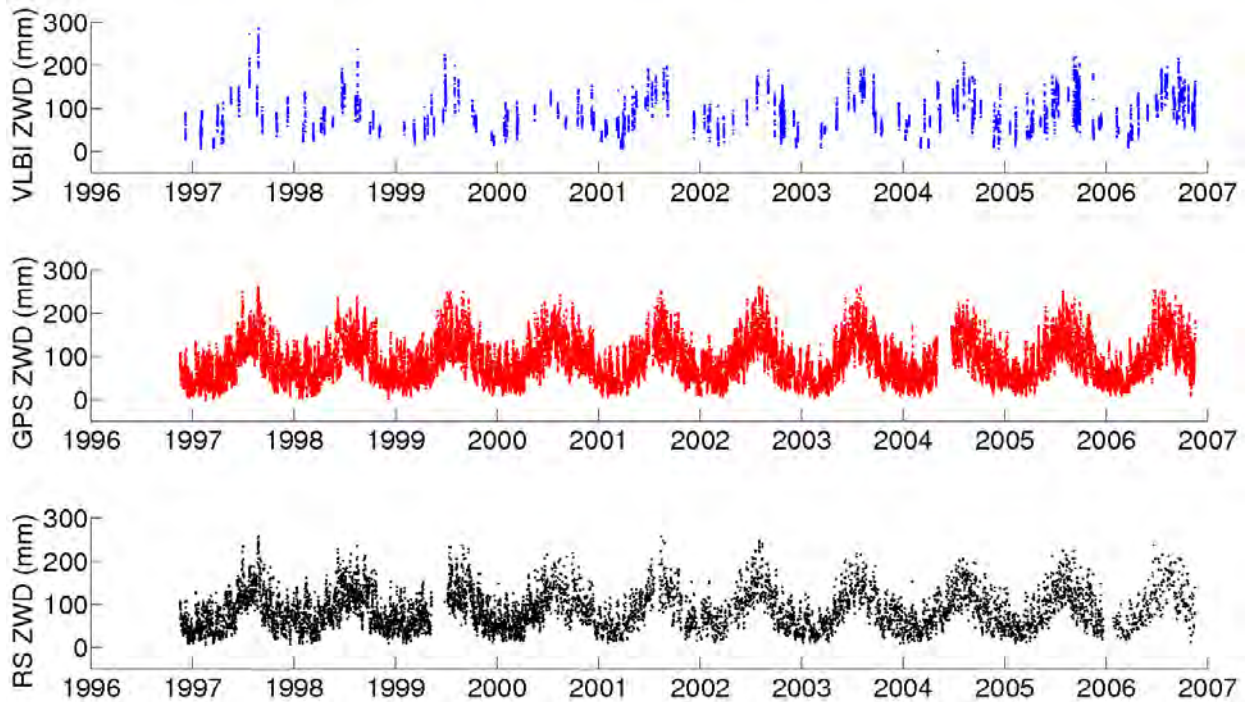

Figure 2. Time series of the equivalent zenith wet delay (ZWD) estimated from VLBI data (top), GPS data (middle), and radiosonde (RS) data (bottom).

## 5. Ultra-rapid dUT1 Observations

We compared the results of the Fennoscandian-Japanese ultra-rapid dUT1 experiments [10] with the corresponding values of the IERS Bulletin-A, the IERS rapid service) and the IERS Bulletin-B [11]. As a reference for the comparison, we used the IERS C04 series. The study shows that the agreement of the ultra-rapid dUT1 results with IERS C04 is on the same level as the IERS rapid values. However, the latency of the ultra-rapid dUT1 values is much shorter and can be on the order of a couple of minutes [12].

## 6. Contribution to the IVS Trop Project

During 2009 we started again slowly to contribute to the IVS Trop Project. So far we contributed time series of tropospheric parameters for CONT08. The plan is, however, to restart a regular contribution with the results of all R1 and R4 sessions.

## 7. Ocean Tide Loading

The automatic ocean tide loading provider [13] was maintained during 2009. A small bug in the refinement stage of the loading provider was corrected, and the new ocean model TPXO.7.2 was added [14].

## 8. Outlook

The IVS Analysis Center at the Onsala Space Observatory will continue its efforts to work on specific topics relevant for space geodesy and geosciences. During 2010 we plan to intensify the analysis of VLBI data and, for example, restart our contribution to the IVS TROP project.

## References

- [1] Behrend D, Böhm J, Charlot P, Clark T, Corey B, Gipson J, Haas R, Koyama Y, MacMillan D, Malkin Z, Niell A, Nilsson T, Petrachenko B, Rogers A E E, Tuccari G, & Wresnik J (2008) Recent progress in the VLBI2010 development. In: *Proc. IUGG XXIV General Assembly 2007*, Observing our Changing Earth, IAG Symposia, 133, 833–840, Springer, doi:10.1007/978-3-540-85426-5.
- [2] Petrachenko B, Niell A, Behrend D, Corey B, Böhm J, Charlot P, Collioud A, Gipson J, Haas R, Hobiger T, Koyama Y, MacMillan D, Malkin Z, Nilsson T, Pany A, Tuccari G, Whitney A, & Wresnik J (2009) Design Aspects of the VLBI2010 System. **NASA/TM-2009-214180**, 58 pages.
- [3] Nilsson T, & Haas R (2009) An Assessment of Atmospheric Turbulence for CONT05 and CONT08. In: *Proc. 19th EVGA Working Meeting*, G. Bourda, P. Charlot, and A. Collioud (eds.), 39–43.
- [4] Nilsson T, & Haas R (2010) Impact of atmospheric turbulence on geodetic very long baseline interferometry. *Journal of Geophysical Research*, doi:10.1029/2009JB006579, in press.
- [5] Nilsson T, Haas R, & Elgered G (2007) Simulations of atmospheric path delays using turbulence models. In: *Proc. 18th EVGA Working Meeting*, J. Böhm, A. Pany, and H. Schuh (eds.), 175–180.
- [6] Nilsson T, & Haas R (2008) Modeling Tropospheric Delays with Atmospheric Turbulence Models. In: *Proc. 5th IVS General Meeting*, A. Finkelstein and D. Behrend (eds.), 361–370.
- [7] Ma C, Sauber J M, Bell L J, Clark T A, Gordon D, Himwich W E & Ryan J W (1990) Measurement of horizontal motions in alaska using very long baseline interferometry. *Journal of Geophysical Research*, **95(B13)**, 21 991–22 011, doi:10.1029/JB095iB13p21991.
- [8] Garcia-Espada S, Colomer Sanmartin F, & Haas R (2009) Simulations of Different Antenna Velocities in VLBI Networks. In: *Proc. 19th EVGA Working Meeting*, G. Bourda, P. Charlot, and A. Collioud (eds.), 169–172.
- [9] Elgered G, Haas R, & Nilsson T (2009) Atmospheric VLBI: A method to validate long time series of water vapour content. In: *Proc. 19th EVGA Working Meeting*, G. Bourda, P. Charlot, and A. Collioud (eds.), 49–53.
- [10] Sekido M, Takiguchi H, Koyama Y, Kondo T, Haas R, Wagner J, Ritakari J, Kurihara S, Kokado K (2008) Ultra-rapid UT1 measurements by e-VLBI. *Earth Planets and Space*, **60**, 865–870.
- [11] Haas R, Sekido M, Kurihara S, Hobiger T, Wagner J, Kondo T, Koyama Y, Tanimoto D, Takiguchi H, Kokado K, Ritakari J, & Mujunen A (2009) Ultra-rapid dUT1-observations with e-VLBI. Presentation at *IERS Workshop on EOP Combination and Prediction, Warsaw, 19-21 October 2009*, [www.cbk.waw.pl/EROPP2009/contributions/session1/session1.1/mon09\\_Haas\\_et\\_al\\_IERS\\_2009.pdf](http://www.cbk.waw.pl/EROPP2009/contributions/session1/session1.1/mon09_Haas_et_al_IERS_2009.pdf).
- [12] Matsuzaka S, Shigematsu H, Kurihara S, Machida M, Kokado K, & Tanimoto D (2008) Ultra Rapid UT1 Experiment with e-VLBI. In: *Proc. 5th IVS General Meeting*, A. Finkelstein and D. Behrend (eds.), 68–71.
- [13] Scherneck H-G, & Bos M (2002) Ocean Tide and Atmospheric Loading. In: *IVS 2002 General Meeting Proceedings*, N. R. Vandenberg and K. D. Baver (eds.), **NASA/CP-2002-210002**, 205–214.
- [14] Egbert G D, & Erofeeva L (2002) Efficient inverse modeling of barotropic ocean tides. *Journal of Atmospheric and Oceanic Technology*, **19**,183–204.



# Pulkovo IVS Analysis Center (PUL) 2009 Annual Report

*Zinovy Malkin, Natalia Miller, Elena Popova*

## Abstract

This report briefly presents the PUL IVS Analysis Center activities during 2009 and plans for the coming year. The main topics of the investigations of PUL staff in that period were ICRF related studies, computation and analysis of EOP series, and VLBI2010 related issues.

## 1. General Information

The PUL IVS Analysis Center was organized in September 2006 and is located at the Central Astronomical Observatory at Pulkovo of Russian Academy of Sciences (Pulkovo Observatory). It is a part of the Pulkovo EOP and Reference Systems Analysis Center (PERSAC). The main topics of our IVS related activity are:

- Improvement of the International Celestial Reference Frame (ICRF), including investigations of stochastic and systematic errors of radio source catalogs, construction of combined catalogs, investigation of the ICRF stability, and investigation of radio source position time series.
- Computation and analysis of EOP, station position, baseline length, and zenith troposphere delay time series.
- Investigation of the Free Core Nutation (FCN).
- Comparison of VLBI results with other space geodesy techniques.
- Observation statistics.

The PUL AC's Web page [http://www.gao.spb.ru/english/as/ac\\_vlbi/](http://www.gao.spb.ru/english/as/ac_vlbi/) is supported. The homepage contains the following sections:

- General Information: brief history, activity overview, staff.
- Data files used in analysis: station information adapted to the SINEX SITE/ID format, a database name/experiment code cross-reference table including the number of actually observed stations based on the IVS master file, average meteo parameters for stations based on information from databases, and a catalog of optical characteristics of astrometric radio sources (OCARS).
- Observation statistics based on the PUL archive of NGS cards mainly obtained from the IVS Data Center: session statistics, global statistics, station/date statistics, and problems (duplicate observations, mixed baselines, absent or suspicious meteo data, etc.)—updated with every new database.
- Results of analysis: currently only two FCN series and mean Pole coordinates are available. These are updated daily.
- Publications and presentations.
- Links to the VLBI World.
- Contact information.

## 2. Scientific Staff

The PUL team in 2009 includes:

1. Zinovy Malkin (70%) — team coordinator, EOP and CRF computation and analysis;
2. Natalia Miller (10%) — EOP and zenith troposphere delay analysis;
3. Julia Sokolova — CRF computation and analysis; on leave of absence at the Curtin University of Technology since November;
4. Elena Popova (100%) — radio source velocities and EOP analysis.

## 3. Activities

The main activities of the PUL IVS Analysis Center during 2009 included:

- ICRF related research was continued, mainly in the framework of the IERS/IVS Working Group on the Second Realization of the ICRF. The main directions of this activity were comparison and combination of radio source catalogs, investigation of their stochastic and systematic errors, investigation of the systematic differences between catalogs obtained with different analysis options, and source position time series analysis. The main results obtained in 2009 are the following:
  - Source position time series submitted in the framework of the ICRF2 activity were analyzed with respect to the selection of defining and non-stable sources [1].
  - Systematic effects in the source motions were studied using the same source position time series [2].
  - The work on the catalog of optical characteristics of geodetic radio sources (OCARS) and its use in data analysis was continued [3]. The first results of the determination of the redshifts of selected geodetic sources were obtained [4].
- Relativistic effects which can be observed during the occultations of and close approaches to geodetic radio sources by planets were re-visited, and a new catalog of the forthcoming close approaches and occultations through the year 2050 was computed [5].
- Investigations of the empiric FCN models were continued [6]. Regular computation of two refined FCN series was continued.
- VLBI2010 related studies were conducted in two directions: participation in the IVS VLBI2010 Committee and participation in the development of a Russian VLBI network in accordance with the VLBI2010 specifications.
- PUL archive of VLBI data and products is supported. At present, all available databases and NGS cards have been stored along with the main IVS and IERS products.
- Development of algorithms and software for data processing and analysis was continued.
- PUL staff members participated in activities of several IERS, IAG, and IVS projects, Working Groups, and Committees.

## 4. Outlook

Plans for the coming year include:

- Continuation of the IVS related studies.
- Development of algorithms and software used for data processing.
- Support of the PUL archive of data and products.

## References

- [1] Malkin Z. Some Results of Analysis of Source Position Time Series. IVS Memorandum 2009-001v01, <ftp://ivscc.gsfc.nasa.gov/pub/memos/ivs-2009-001v01.pdf>.
- [2] Popova E.A. Investigation of systematic variations of the radio source coordinates using position time series. *Izvestiya GAO*, 2009, No. 219(4), Proceedings of the All-Russian Astrometry Conference “Pulkovo-2009”, St. Petersburg, June 15-19, 273–278. (in Russian)
- [3] Titov O., Malkin Z. Effect of asymmetry of the radio source distribution on the apparent proper motion kinematic analysis. *Astron. Astrophys.*, 2009, v. 506, No. 3, 1477–1485.
- [4] Maslennikov K., A. Boldycheva, Z. Malkin, O. Titov. Determination of Redshifts for Selected IVS Sources. I. arXiv:0912.5431, 2009.
- [5] Malkin Z.M., L’vov V.N., Tsekmejster S.D. Forthcoming Close Angular Approaches of Planets to Radio Sources and Possibilities to Use Them as GR Tests. *Solar System Research*, 2009, v. 43, No. 4, 313–318.
- [6] Malkin Z.M. A comparison of empiric Free Core Nutation models. *Izvestiya GAO*, 2009, No. 219(4), Proceedings of the All-Russian Astrometry Conference “Pulkovo-2009”, St. Petersburg, June 15–19, 205–210. (in Russian)

# SAI VLBI Analysis Center Report 2009

*Vladimir Zharov, Mark Kaufman*

## Abstract

This report presents an overview of the SAI VLBI Analysis Center activities during 2009 and the plans for 2010. The SAI AC analyzes all IVS sessions for computation of the Earth orientation parameters (EOP), time series of source positions at the scope of future realizations of the ICRF, makes submissions of data and analysis products, and performs research and software development aimed at improving the VLBI technique.

## 1. General Information

The SAI VLBI Analysis Center is located at Sternberg State Astronomical Institute of Lomonosov Moscow State University in Moscow, Russia. The Analysis Center participates in geodetic and astrometric VLBI analysis, software development, and research aimed at improving the VLBI technique.

## 2. Component Description

The SAI AC performs data processing of all kinds of VLBI observation sessions. For VLBI data analysis we use the ARIADNA software package developed at SAI. All reductions are performed in agreement with the IERS Conventions (2003).

Our package uses files in the NGS format as input data.

## 3. Staff

- Vladimir Zharov, Prof.: development of the ARIADNA software, development of the methods of parameter estimation.
- Mark Kaufman, scientific researcher: development of the ARIADNA software, solutions, and analysis
- Dmitry Duev, post-graduate student: VLBI data processing, troposphere modeling
- Nikolay Voronkov, scientific researcher: global solutions

## 4. Current Status and Activities

- **Software development for VLBI processing**

The ARIADNA software is being developed to provide contributions to IVS products. The software is used for calculating all types of IVS products.

- **Routine analysis**

During 2009 the routine data processing was performed with the ARIADNA software using the least-squares method with constraints. The SAI AC operationally processed the 24-hour

and Intensive VLBI sessions. The formation of data bases for the VLBI sessions and the processing of all sessions is fully automated. The EOP series sai2008a.eops and sai2008a.eopi were continued. These series were computed with the catalog ITRF2005 of station positions and velocities.

Differences  $\Delta$  between the EOP from solutions sai2008a.eops and EOP05C04 and the variance  $\sigma$  of each difference are shown in Table 1. The values of  $\Delta$  are WRMS estimates for the period 1984—2008.

Table 1. Difference between EOP from solutions sai2008a.eops and EOP05C04 and variance.

<i>EOP</i>	$\Delta$	$\sigma$
$x, \mu as$	-66	272
$y, \mu as$	-54	281
$UT1 - UTC, \mu s$	-2	13
$\Delta\psi \sin \varepsilon, \mu as$	-49	437
$\Delta\varepsilon, \mu as$	7	206

- **Global solution**

During 2009 software to obtain a global solution was developed and tested by N. Voronkov. Data for 2008 were processed. The radio source coordinates and velocities and the station coordinates and velocities were estimated as global parameters. EOP, troposphere wet zenith delay (approximated as a polynomial function), troposphere gradients, and station clocks (approximated as a polynomial function) were estimated as arc parameters for each session. The variance  $\sigma_1$  of differences between the EOP from solution sai2008a.eops and gsf2008a.eops and  $\sigma_2$  between global solution and gsf2008a.eops are shown in Table 2.

Table 2. Comparison of EOP (solution sai2008a.eops and global solution for 2008) to solution gsf2008a.eops.

<i>EOP</i>	$\sigma_1$	$\sigma_2$
$x, \mu as$	260	30
$y, \mu as$	390	30
$UT1 - UTC, \mu s$	7	0.8
$\Delta\psi \sin \varepsilon, \mu as$	600	30
$\Delta\varepsilon, \mu as$	250	10

- **Participation in the IERS/IVS Working Group on the Second Realization of the ICRF**

Time series of frequently observed sources were calculated using the ARIADNA software. Source positions for every source were obtained from a solution for each VLBI 24-hour session. A priori source positions were taken from the ICRF-Ext.2 catalog. Corrections of the coordinates of defining sources were calculated with the NNR constraint, and coordinate corrections for other sources were calculated without this constraint.

It was shown that some of the radio sources, including the defining sources, show significant apparent motion [1]. The method of approximation of time series of coordinates by polynomial models was used, and a few methods to select stable radio sources were suggested [2]. The linear and uniform motion of sources has been explained by the precession of jet. Some of the sources demonstrate non-uniform motion related to the acceleration processes of the matter in jets.

The motion of the defining sources leads to a rotation of the celestial reference frame axes. To improve the stability of the ICRF, we suggested additional principles for the generation of the new ICRF catalog [3]. The new selection criteria are based on not only statistical properties of the position time series but also on physical properties of the quasars. It was shown that inclusion of a subset of sources formed on the basis of cosmological criteria makes stability of the ICRF better. The main conclusion of our work is that any new catalog of reference radio sources has to contain both coordinates and apparent motions.

- **Troposphere modeling**

At the stations with missing meteorological data, we used surface data files (temporal coverage: four times daily; spatial coverage: a 2.5 degree latitude x 2.5 degree longitude global grid) from NCEP/NCAR Reanalysis (<http://www.cdc.noaa.gov/data/gridded/data.ncep.reanalysis.surface.html>) for calculating air temperature, pressure and relative humidity. For that purpose a program was written to interpolate these data to the given coordinates of the station at the time of the observations.

For calculating the atmospheric path delay, a sophisticated tool was developed (D. Duev). It uses the ray-tracing technique through the NOAA NCEP/NCAR Reanalysis I numerical weather model (3-D pressure level data). Transformation of meteorological parameters (temperature, pressure, and relative humidity) into refractive index was made with the help of the MPM93 model. The tool developed performs slightly better (or at least not worse) than results based on Vienna Mapping Functions I (VMF1) and Niell Mapping Functions (NMF) which are widely used in VLBI and GPS analysis. The increase of spatial and temporal resolution of the NMW will immediately improve the quality of results obtained with our tool.

## 5. Future Plans

We plan to:

- Continue to submit all types of IVS product contributions and to start to submit SINEX files both for IVS 24-hour and Intensive sessions.
- Continue investigations of VLBI estimation of EOP, station coordinates, and troposphere parameters, and comparison with satellite techniques.
- Continue studies in the framework of the Third Realization of the ICRF.
- Further improve algorithms and software for processing VLBI observations.

## References

- [1] V. E. Zharov, M. V. Sazhin, V. N. Sementsov, K. V. Kuimov, O. S. Sazhina, Physical Origins for Variations in the Apparent Positions of Quasars. *Astronomy Reports*, v.53, p.579, 2009.
- [2] V. E. Zharov, M. V. Sazhin, V. N. Sementsov, K. V. Kuimov, O. S. Sazhina, N. T. Ashimbaeva. The celestial reference frame stability and apparent motions of the radio sources. In “Relativity in Fundamental astronomy: dynamics, reference frames and data analysis”. Proc. of the IAU Symp. 261. Ed. by S. A. Klioner, P. K. Seidelmann and M. H. Soffel 2010, Cambridge Univ. Press, p. 50-55.
- [3] V. E. Zharov, M. V. Sazhin, V. N. Sementsov, K. V. Kuimov, O. S. Sazhina, and N. T. Ashimbaeva. Principles for Selecting a List of Reference Radio Sources for a Celestial Coordinate System. *Astronomy Reports*, v. 54, p. 112, 2010.

# SHAO Analysis Center 2009 Annual Report

*Guangli Wang, Jinling Li, Bo Zhang, Li Guo, Fengchun Shu, Zhihan Qian*

## Abstract

This report gives an introduction to the astrometric/geodetic activities of the Shanghai Astronomical Observatory (SHAO) in 2009. They are summarized as follows: the observation and processing of the VLBI experiments with the Chinese VLBI Network (CVN) and the research activities geared towards VLBI2010.

## 1. General Information

We use the CALC/SOLVE system for routine VLBI data analysis. The members involved in the IVS analysis activities are Guangli Wang, Jinling Li, Bo Zhang, Li Guo, Fengchun Shu, and Zhihan Qian.

## 2. Activities in 2009

We participated in some IERS/IVS campaigns aimed at comparisons of reference frames and/or Earth Rotation Parameters. Our research activities in 2009 were related to the VLBI experiments and data analysis of the Chinese VLBI Network (CVN), as well as to observations, models, algorithms, and software implementation geared towards VLBI2010.

### 2.1. Astrometric and Geodetic VLBI Experiments and Data Analysis

For the compilation of ITRF2008, we submitted our solutions to IVS. We conducted VLBI experiments using the CVN, including the antennas at Shanghai, Urumqi, Beijing, and Kunming, and we performed the related data analysis in order to determine the station coordinates, especially those of the two new stations for the Chinese space exploration projects, as well as for the Project of the Monitoring Network of the Chinese Mainland Geological Environment.

### 2.2. Work Concerning VLBI2010

We set up a domestic seminar in 2008 to investigate and evaluate the current status of astrometric and geodetic VLBI, and our goal is to give a report about the efforts to be done towards VLBI2010 in the areas of observations, models, algorithms, and software. As we know, the IVS community has been carrying out similar work, but by doing the work, we are trying to determine some aspects in which we can make contributions, and we are also trying to promote the theoretical abilities of our research group.

### 2.3. Site Survey at the Sheshan 25-m Radio Telescope

We conducted a site survey at the Sheshan 25-m radio telescope in July and August 2008 in order to develop a strategy of observing and data analysis, to develop software, and to check the precision of parameter solutions. This survey is a part of the whole effort to determine the local tie parameters among the sites of VLBI and SLR at Sheshan. Such parameters are important to



the compilation of terrestrial reference frames based on various space geodetic techniques. The data were re-analyzed this year.

### **3. Plans for 2010**

We will enhance the IVS analysis work, return to our normal contributions of solutions to IVS, and make more active efforts to be involved in the activities of the VLBI community.

## U.S. Naval Observatory VLBI Analysis Center

*David A. Boboltz, Alan L. Fey, Nicole Geiger, Roopesh Ojha, Zachary Dugan,  
Kerry A. Kingham, David M. Hall*

### Abstract

This report summarizes the activities of the VLBI Analysis Center at the United States Naval Observatory for calendar year 2009. Over the course of the year, Analysis Center personnel continued analysis and timely submission of IVS-R4 databases for distribution to the IVS. During the 2009 calendar year, the USNO VLBI Analysis Center answered a call for contributions to ITRF2008 and produced two periodic global Terrestrial Reference Frame (TRF) solutions for internal use only. Earth orientation parameters (EOP), updated by the latest diurnal (IVS-R1 and IVS-R4) experiments, were routinely submitted to the IVS. Sinex files based upon the bi-weekly 24-hr experiments were also submitted to the IVS, and in 2009, the Analysis Center began production of a Sinex series based upon the 1-hr Intensives.

Other activities in the 2009 calendar year included continued research into celestial reference frames. Analysis Center personnel made significant contributions to the recently approved Second Realization of the ICRF (ICRF2) and continued research into future high-frequency reference frames based upon the VLBA K/Q-band experiments. VLBI Analysis Center personnel also implemented the DiFX software correlator at USNO and were involved in its testing and evaluation. Finally, a program of observations using the Very Long Baseline Array (VLBA) were initiated to test the feasibility of using the VLBA to measure UT1-UTC.

## 1. Introduction

The USNO VLBI Analysis Center is supported and operated by the United States Naval Observatory (USNO) in Washington, DC. The primary services provided by the Analysis Center are the analysis of diurnal experiments, the production of periodic global Terrestrial Reference Frame (TRF) and Celestial Reference Frame (CRF) solutions, and the submission to the IVS of Intensive (EOP-I) and session-based (EOP-S) Earth orientation parameters based on USNO global TRF solutions. Analysis Center personnel maintain the necessary software required to continue these services to the IVS including periodic updates of the GSFC CALC/SOLVE software package. In addition to operational VLBI analysis, Analysis Center personnel are actively engaged in research related to future reference frames, e-VLBI, and software correlation.

## 2. Current Analysis Center Activities

### 2.1. IVS Experiment Analysis and Database Submission

During the 2009 calendar year, personnel at the USNO VLBI Analysis Center continued to be responsible for the timely analysis of the IVS-R4 experiments, with the resulting databases to be submitted within 24 hours of correlation for dissemination by the IVS. Due to a decrease in staffing, the Analysis Center temporarily suspended in-house analysis of the IVS-R1 experiments in favor of using the databases submitted by NASA GSFC. Analysis Center personnel continue to be responsible for the analysis and database submission for the periodic IVS-CRF experiments. The primary goal of these experiments is the densification of ICRF sources in the southern hemisphere. In 2009, USNO scheduled and analyzed four CRF related experiments including IVS-CRF55 through IVS-CRF57, and IVS-CRFS13. The analyzed databases were submitted to the IVS. Analysis Center

personnel also continued analyzing IVS Intensive experiments for use in the USN-EOPI time series.

## 2.2. Global TRF Solutions, EOP and Sinex Submission

During 2009, Analysis Center personnel answered an IVS call for contributions to ITRF2008 by producing a series of Sinex files based on the entire USNO data set dating back to 1979. This series departed from the typical USNO Sinex distribution by making use of the Vienna Mapping Function (VMF) for tropospheric delay determination. The Sinex series was submitted to the IVS Analysis Coordinator for use in ITRF2008.

USNO VLBI Analysis Center personnel continued to produce periodic global EOP/TRF solutions (usn2009a and usn2009b) over the course of the 2009 calendar year. However, these solutions were produced for internal use only, and they were not submitted to the IVS. Analysis Center personnel continued to submit the USN-EOPS series based on the global TRF solutions updated with new IVS-R1/R4 experiments. The updated EOPS series was submitted to the IVS twice weekly within 24 hours of experiment correlation and is included in the IERS Bulletin A. Analysis Center personnel also continued routine submission of Sinex format files based upon the 24-hr VLBI sessions. In addition to EOPS and Sinex series, USNO VLBI Analysis Center personnel continued to produce and submit an EOPI series based upon the IVS intensive experiments.

## 2.3. Celestial Reference Frame (CRF)

During the 2009 calendar year, Analysis Center personnel primarily focused on the completion of the Second Realization of the International Celestial Reference Frame (ICRF2) for approval by the International Astronomical Union (IAU). In preparation for ICRF2, Analysis Center personnel produced multiple CRF solutions, performed time series analysis of source position variations for the purpose of source classification, and investigated the feasibility of adding the VLBA Calibrator Survey sources to the CRF. On 13 August 2009, Resolution B3 adopting the ICRF2 as the fundamental celestial reference frame as of 1 January 2010 was approved by the XXVII IAU General Assembly. ICRF2 includes a total of 3414 extragalactic sources of which 295 were selected as “defining” sources. The sky distribution of the ICRF2 Defining sources is shown in Figure 1. USNO VLBI Analysis Center personnel made significant contributions to the IERS Technical Note No. 35, which provides a complete description of ICRF2 and is available at the following Web site:

<http://www.iers.org/MainDisp.csl?pid=46-1100252>.

In 2009, Analysis Center personnel continued to collaborate with colleagues from Bordeaux Observatory, NASA GSFC, NASA HQ, NASA JPL, and NRAO on a program of high-frequency reference frame observations made with the VLBA. This project aims to investigate the feasibility of a CRF at frequencies between 24 and 43 GHz. Two sessions were observed in 2009 (BL151a and BL151b) bringing the total to 12. Four additional epochs were approved for observation in 2009-2010 (BL166). Results from the program are presented in two upcoming articles (Lanyi et al. 2010, AJ, in press; Charlot et al. 2010, AJ, in press).

## 2.4. Software Correlator

Over the course of the 2009 calendar year, Analysis Center personnel began implementation, testing and evaluation of the DiFX software correlator. USNO currently has a small cluster of five multi-core machines on which the software correlator is implemented. Analysis Center personnel

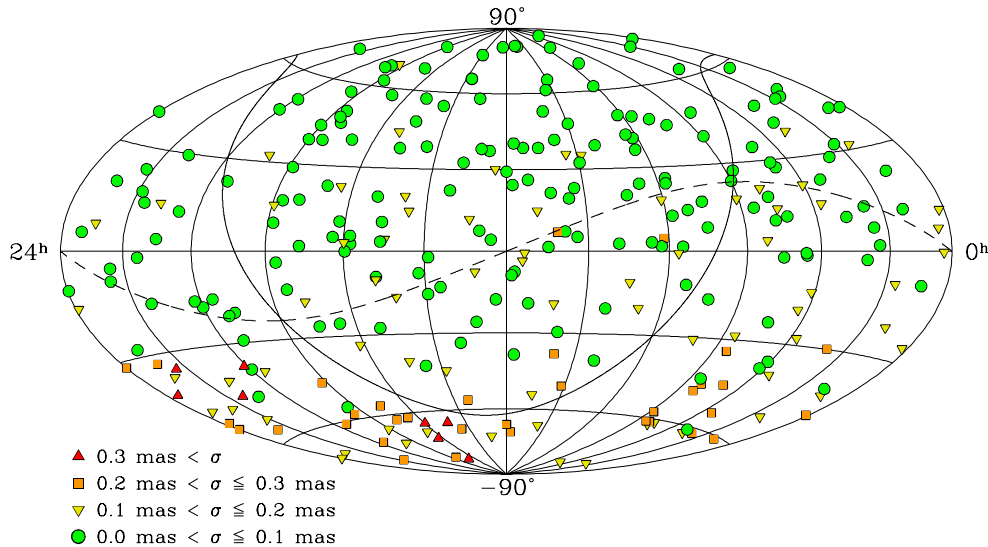

Figure 1. The distribution of the 295 ICRF2 Defining sources on an Aitoff equal area projection of the celestial sphere.

have been interfacing with colleagues at various institutions and attended a DiFX meeting in Perth, Australia in October of 2009. Post-correlation calibration is currently being performed within the Astronomical Image Processing System (AIPS), and the database production and analysis is performed within CALC/SOLVE.

## 2.5. VLBA EOP Experiments

During the 2009 calendar year, Analysis Center personnel began a program to test the feasibility of using the Very Long Baseline Array (VLBA) operated by the National Radio Astronomy Observatory (NRAO) for the purpose of measuring UT1-UTC. A secondary goal of the observations was to test the implementation of the DiFX software correlator at USNO. In Feb. 2009, a series of test observations (TC015) were begun. These observations consisted of five antennas of the VLBA and were scheduled in a geodetic mode optimized for the Mauna Kea to St. Croix baseline with the remaining three antennas (Hancock, Los Alamos, and Pie Town) as tag-along stations. All of the data from the experiments were correlated on the software correlator and compared to results from the NRAO hardware correlator. The data were further analyzed within CALC/SOLVE, and EOPI results compared to other USNO EOP series. Figure 2 shows differences between IERS-C04-05 and the TC015 results. The panel on the left shows the results for just the MK-SC baseline, while the right panel shows the results for all 5 stations combined. Differences between IERS C04-05 and the USN-EOPI and USN-EOPS series are also shown. The TC015 series continued through the end of 2009 and will continue at monthly intervals through mid-2010 in order to cover a full Chandler cycle. An additional series (TB014) was recently approved for observation by the VLBA

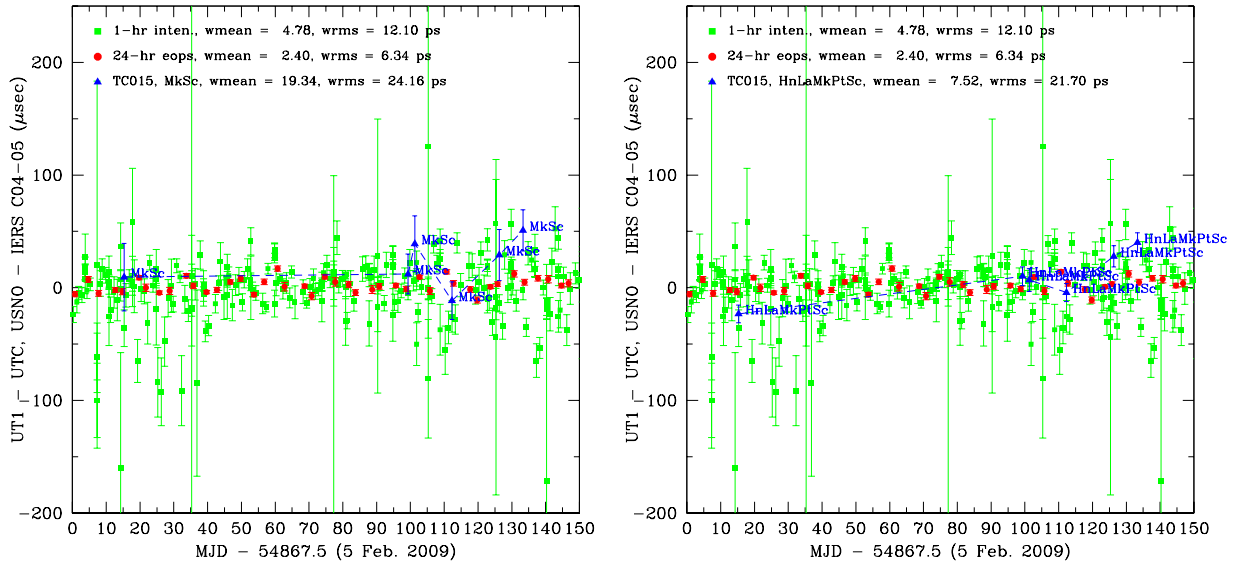

Figure 2. Differences in UT1-UTC between IERS C04-05 and data from VLBA experiment TC015. The left panel shows results for the primary baseline MK-SC. The right panel shows results for all five stations combined. Also shown in each panel are differences between IERS C04-05 and both the USN-EOPI and USN-EOPS standard series for comparison.

in 2010. This series will include only three stations—Mauna Kea, Los Alamos, and Pie Town—and will test the effects of shorter baselines on UT1-UTC.

### 3. Staff

The staff of the VLBI Analysis Center is drawn from individuals in both the Astrometry and Earth Orientation departments at the U.S. Naval Observatory. The staff and their responsibilities are as follows:

Name	Responsibilities
David Boboltz	Periodic global TRF solutions and comparisons, Sinex generation and submission, Web page administration, VLBI data analysis.
Alan Fey	Periodic global CRF solutions and comparisons, CRF densification research, Web page administration, VLBI data analysis.
Nicole Geiger	VLBI data analysis, EOP and database submission.
Roopesh Ojha	Software correlator implementation, VLBA scheduling and data analysis.
Zachary Dugan	VLBI data analysis, EOP and database submission.
Kerry Kingham	Correlator interface, VLBI data analysis.
David Hall	Correlator interface, VLBI data analysis.

# USNO Analysis Center for Source Structure Report

*Alan L. Fey, David A. Boboltz, Roopesh Ojha, Ralph A. Gaume, Kerry A. Kingham*

## Abstract

This report summarizes the activities of the United States Naval Observatory Analysis Center for Source Structure for calendar year 2009. VLBA RDV experiments RDV71 and RDV73 were calibrated and imaged. Images from these two experiments, together with images from RDV25 were added to the USNO Radio Reference Frame Image Database. VLBA high frequency (K/Q-band) experiment BL151a was calibrated and imaged. A Southern Hemisphere imaging and astrometry program for maintenance of the ICRF continued. Activities planned for the year 2010 include continued imaging of ICRF sources at standard and higher frequencies and continued analysis of source structure and its variation.

## 1. Analysis Center Operation

The Analysis Center for Source Structure is supported and operated by the United States Naval Observatory (USNO). The charter of the Analysis Center is to provide products directly related to the IVS determination of the “definition and maintenance of the celestial reference frame.” These include, primarily, radio frequency images of ICRF sources, intrinsic structure models derived from the radio images, and an assessment of the astrometric quality of the ICRF sources based on their intrinsic structure.

The Web server for the Analysis Center is hosted by the USNO and can be accessed by pointing your browser to

[http://rorf.usno.navy.mil/ivs\\_saac/](http://rorf.usno.navy.mil/ivs_saac/)

The primary service of the Analysis Center is the Radio Reference Frame Image Database (RRFID), a Web accessible database of radio frequency images of ICRF sources. The RRFID contains 6,747 Very Long Baseline Array (VLBA) images (an 8.3% increase over the previous year) of 711 sources (a 3.8% increase over the previous year) at radio frequencies of 2.3 GHz and 8.4 GHz. Additionally, the RRFID contains 1519 images (a 13% percent increase over the previous year) of 280 sources (a 2.2% increase over the previous year) at frequencies of 24 GHz and 43 GHz. The RRFID can be accessed from the Analysis Center Web page or directly at

<http://rorf.usno.navy.mil/rrfid.shtml>

The RRFID also contains 74 images of 69 Southern Hemisphere ICRF sources using the Australian Long Baseline Array (LBA) at a radio frequency of 8.4 GHz. Images of ICRF sources can also be obtained from the Bordeaux VLBI Image Database (BVID) at

<http://www.obs.u-bordeaux1.fr/m2a/BVID/>

Shown in Figure 1 is the distribution of the mean structure index for 707 sources with VLBI images available from the RRFID and the BVID. These data and analysis were directly involved in the selection of the defining sources for the second realization of the International Celestial Reference Frame (ICRF2; <http://www.iers.org/MainDisp.csl?pid=46-1100252>).

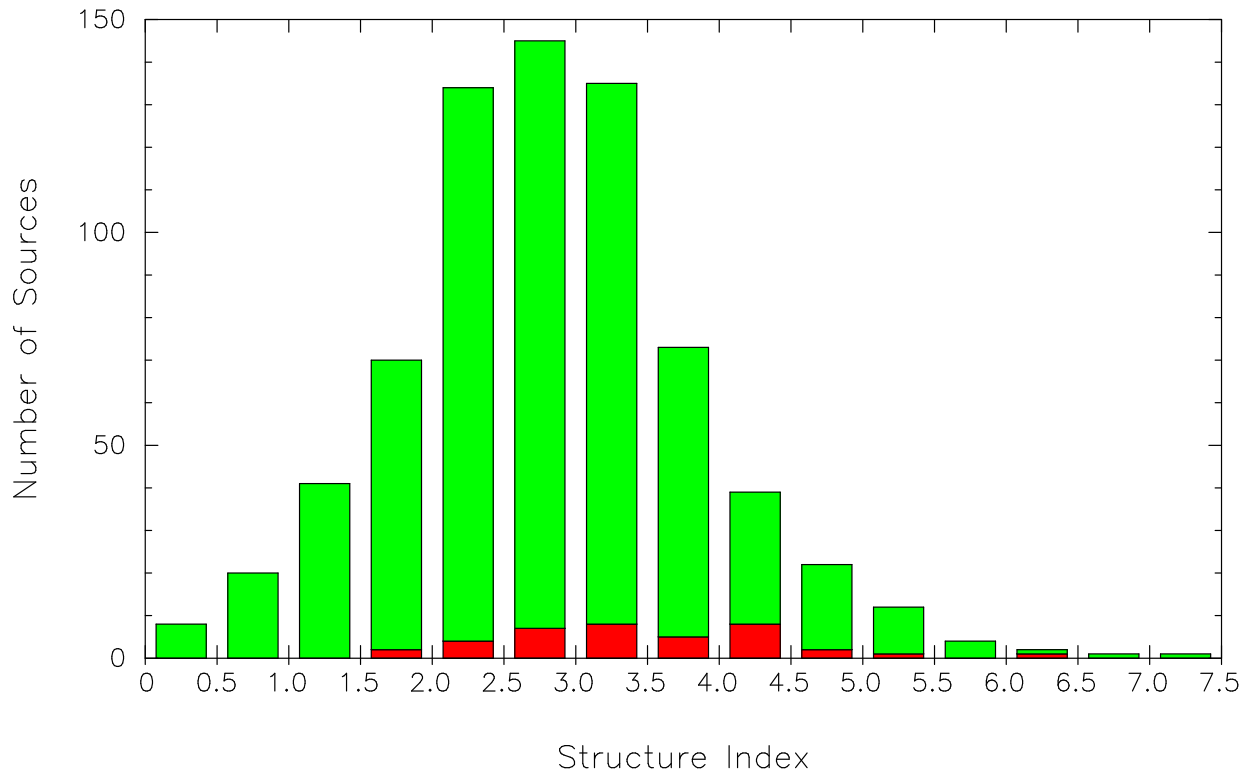

Figure 1. Distribution of the mean structure index for 707 radio sources with VLBI images available from the USNO Radio Reference Frame Image Database or Bordeaux VLBI Image Database. The 39 special handling sources discussed in IERS Technical Note 35 are color-coded in the darker shade of gray.

## 2. Current Activities

### 2.1. VLBA Imaging

Very Long Baseline Array (VLBA) observations for maintenance of the celestial and terrestrial reference frames have been carried out since about 1994. Since 1997, these VLBA RDV observations have been part of a joint program between the USNO, the Goddard Space Flight Center (GSFC) and the National Radio Astronomy Observatory (NRAO). During each 24 hour VLBA RDV session, about 100 ICRF sources are observed at S/X-band (2.3/8.4 GHz) using the VLBA, together with up to 10 additional geodetic antennas. Images are produced from these observations and made available through the RRFID.

VLBA experiment RDV73 (2009JAN21) was calibrated and imaged, adding 175 (87 S-band; 88 X-band) images to the RRFID, including images of 23 sources (0035-252, 0043-268, 0055-059, 0420+022, 0502-152, 0515+208, 0529+483, 0532-378, 0632-235, 0741-444, 0847-120, 0915-118, 1059-438, 1133-032, 1243-160, 1428+370, 1602-115, 1633-409, 1650-157, 1711-209, 1913-272, 2157-255, and 2220-318) not previously imaged.

VLBA experiment RDV71 (2008SEP03) was calibrated and imaged, adding 168 (84 S-band; 84 X-band) images to the RRFID.

VLBA experiment RDV25 (2001JAN29) was calibrated and imaged, adding 175 (87 S-band;

88 X-band) images to the RRFID, including images of two sources (1604-333 and 2312-319) not previously imaged. These results were contributed by Glenn Piner and Christopher Marvin of Whittier College, who calibrated, edited, and imaged the data.

Collaborations continue with Glenn Piner at Whittier College and Patrick Charlot of Bordeaux University to calibrate and image several of the VLBA RDV experiments.

## 2.2. VLBA High Frequency Imaging

VLBA observations to extend the ICRF to 24 and 43 GHz continued in 2009. These observations are part of a joint program between the National Aeronautics and Space Administration, the USNO, the National Radio Astronomy Observatory (NRAO), and Bordeaux Observatory. During the calendar year 2009 two papers, submitted for publication in the *Astronomical Journal*, were revised: 1) “The Celestial Reference Frame at 24 and 43 GHz. I. Astrometry” by Lanyi et al. and 2) “The Celestial Reference Frame at 24 and 43 GHz. II. Imaging” by Charlot et al.

VLBA high frequency experiment BL151a was calibrated and imaged, adding 180 images at 24 GHz to the RRFID.

## 2.3. ICRF Maintenance in the Southern Hemisphere

The USNO and the Australia Telescope National Facility (ATNF) continue a collaborative program of VLBI research on Southern Hemisphere source imaging and astrometry using USNO, ATNF, and ATNF-accessible facilities. These observations are aimed specifically toward improvement of the ICRF in the Southern Hemisphere. One celestial reference frame experiment, CRFS13, was scheduled with antennas at Hobart, Australia and the 70-meter Deep Space Network antenna at Tidbinbilla, Australia.

A program to monitor the structure of quasars south of declination  $-30^\circ$  that are either known to be gamma-ray loud or are expected to be gamma-ray loud continued. The program, called TANAMI (Tracking Active galactic Nuclei with Australia Milliarcsecond Interferometry), is observing a sample of about 75 quasars at 8 GHz and 24 GHz bands, with about a third of the sample observed every two months.

## 3. Staff

The staff of the Analysis Center is drawn from individuals who work at the USNO. The staff are Alan L. Fey, David A. Boboltz, Roopesh Ojha, Ralph A. Gaume, and Kerry A. Kingham.

## 4. Future Activities

The Analysis Center currently has a program of active research investigating the effects of intrinsic source structure on astrometric position determination. Results of this program are published in the scientific literature.

The following activities for 2010 are planned:

- Continue imaging and analysis of VLBA 2.3/8.4/24/43 GHz experiments
- Make additional astrometric and imaging observations in the Southern Hemisphere in collaboration with ATNF partners and the TANAMI program team.



## 5. Relevant Publications

Publications of relevance to Analysis Center activities are:

- “The Second Realization of the International Celestial Reference Frame by Very Long Baseline Interferometry”, Presented on behalf of the IERS / IVS Working Group, Alan Fey, David Gordon and Christopher S. Jacobs (eds.). (IERS Technical Note ; 35) Frankfurt am Main: Verlag des Bundesamts für Kartographie und Geodäsie, 2009. 204 p., in print;  
<http://www.iers.org/MainDisp.csl?pid=46-1100252>
- “TANAMI: Milliarcsecond Resolution Observations of Extragalactic Gamma-ray Sources,” Ojha et al. 2009 Fermi Symposium, eConf Proceedings C091122;  
<http://arxiv.org/abs/1001.0059>





Technology Development Centers

Technology Development Centers



# Canadian VLBI Technology Development Center

*Bill Petrachenko*

## Abstract

The Canadian VLBI Technology Development Center (TDC) is involved in activities related to the realization of VLBI2010.

## 1. Introduction

The Canadian TDC is a collaborative effort of the National partners interested in the advancement of VLBI technology, namely the Geodetic Survey Division of Natural Resources Canada (GSD/NRCan) and the Dominion Radio Astrophysical Observatory (DRAO) of the Herzberg Institute for Astrophysics of the National Research Council of Canada, (DRAO/HIA/NRC).

## 2. VLBI2010 Committee (V2C)

The Canadian TDC is primarily focused on encouraging the realization of VLBI2010. This is done by Bill Petrachenko, who is chairman of the V2C, with added contributions by Toni Searle, both of NRCan. In collaboration with others, this year's activity focused on the following areas.

- Completion and final editing of "Design Aspects of the VLBI2010 System: Progress Report of the IVS VLBI2010 Committee"
- Refinement of recommendations for VLBI2010 subsystems with particular attention to the Digital Back End
- Development of strategies for handling systematic errors due to electronics, antenna deformations, and source structure
- Development of algorithms for processing broadband data
- Execution of studies into the nature, impact, and mitigation of Radio Frequency Interference
- Participation in the VLBI2010 Project Executive Group.

## 3. DRAO Activities

Two prototype 10-m composite antennas that are light, stiff, and cost effective have been developed and tested. Under the leadership of Gordon Lacy, design studies for more efficient designs are under way.

Under the leadership of Brent Carlson and Dave Fort, DRAO is completing the production of the correlator for the EVLA project. It is one of the most ambitious radio interferometry correlators ever designed. Correlator expertise at DRAO is now being directed toward novel designs for the SKA.

# FFI Technology Development Center - Software Development

*Per Helge Andersen*

## Abstract

FFI's contribution to the IVS as a Technology Development Center focuses primarily on the development and validation of the GEOSAT software for a combined analysis at the observation level of data from VLBI, GPS, and SLR. This report briefly summarizes the latest improvements of the GEOSAT software. FFI is currently an Analysis Center for IVS and ILRS, and a Technology Development Center for IVS.

## 1. The GEOSAT Software

FFI's contribution to the IVS as a Technology Development Center focuses primarily on the development and validation of the GEOSAT software for a combined analysis at the observation level of data from VLBI, GPS, and SLR. The advantages of the combination of independent and complementary space geodetic data at the observation level is discussed in Andersen ([1]).

The Norwegian Mapping Authority (NMA) and FFI have started a close cooperation in the analysis of space geodetic data using the GEOSAT software. Dr. Per Helge Andersen is responsible for the maintenance of the software. He will also implement a module for the analysis of GRACE data in the software. NMA has employed Dr. Eirik Mysen for model development and implementation in GEOSAT of spaceborne accelerometry and gradiometry, e.g. using data from GOCE. NMA has also employed Dr. Kristian Breili to update the module in GEOSAT for the analysis of satellite altimetry data. The plan is to combine GOCE (gradiometer, GPS, SLR), GRACE (GPS, K-Band range/range difference SST, SLR), Jason (GPS, altimetry, SLR), GPS, LAGEOS and VLBI at the observation level. Data from other satellites may be included later.

## 2. Staff

Dr. Per Helge Andersen—Research Professor of Forsvarets forskningsinstitutt (FFI) and Institute of Theoretical Astrophysics, University of Oslo.

## References

- [1] Andersen, P. H. Multi-level arc combination with stochastic parameters. *Journal of Geodesy* (2000) 74: 531-551.

# GSFC Technology Development Center Report

*Ed Himwich, John Gipson*

## Abstract

This report summarizes the activities of the GSFC Technology Development Center (TDC) for 2009 and forecasts planned activities for 2010. The GSFC TDC develops station software including the Field System, scheduling software (SKED), hardware including tools for station timing and meteorology, scheduling algorithms, and operational procedures. It provides a pool of individuals to assist with station implementation, check-out, upgrades, and training.

## 1. Technology Center Activities

The GSFC IVS Technology Development Center (TDC) develops hardware, software, algorithms, and operational procedures. It provides manpower for station visits for training and upgrades. Other technology development areas at GSFC are covered by other IVS components such as the GSFC Analysis Center. The current staff of the GSFC TDC consists of John Gipson and Ed Himwich, both employed by NVI, Inc. The remainder of this report covers the status of the main areas supported by the TDC.

## 2. Field System

The GSFC TDC is responsible for development, maintenance, and documentation of the Field System (FS) software package. The FS provides equipment control at VLBI stations. It interprets the .snp schedule and .prc procedure files (both as prepared by DRUDG from the .skd schedule). The FS controls the antenna, data acquisition hardware, and related ancillary equipment needed for making VLBI measurements. All major VLBI data acquisition backends are supported. The FS is customizable to allow it to control station specific equipment. It is used at all the IVS network stations (i.e., more than 30) and also at many stations that do VLBI only for astronomical observations. The only major VLBI facilities not using it are the VLBA and VERA.

There were no new releases of the FS during this period. However, there was a release of a new FS Linux kernel distribution (FSL8). This was a cooperative effort between E. Himwich and J. Quick (HartRAO). The associated documentation was updated as well.

In the next year, several other improvements are expected, including:

- Support for DBBC and DBE racks
- Support for Mark 5C recorders
- Development of an antenna interface for Patriot 12-m antennas
- Use of *idl2rpc* for remote operation
- A complete update to the documentation and conversion to a more modern format that will be easier to use
- Conversion of the FORTRAN source to use the *gfortran* compiler; this will enable use of the source level debugger, *gdb*, for development and field debugging
- *Chekr* support for Mark 5A and 5B systems

- Use of the Mark IV Decoder for phase-cal extraction in the field
- FS Linux 9 (based on Debian *squeeze*) distribution
- Support for periodic firing of the noise diode during observations
- Distribution of the new *gnplt*.

### 3. SKED and DRUDG

The GSFC TDC is responsible for the development, maintenance, and documentation of SKED and DRUDG. These two programs are very closely related, and they operate as a pair for the preparation of the detailed observing schedule for a VLBI session and its proper execution in the field. In the normal data flow for geodetic schedules, first SKED is run at the Operation Centers to generate the .skd file that contains the full network observing schedule. Then stations use the .skd file as input to DRUDG for making the control files and procedures for their station. Catalogs are used to define the equipment, stations, sources, and observing modes which are selected when writing a schedule with SKED.

Changes to SKED and DRUDG are driven by changes in equipment and by feedback from the users. The following summarizes some of the important changes to these programs in 2009.

#### 3.1. SKED

The following changes were made to SKED:

- The station limit was increased from 32 to 64, and this was made a parameter so that this can be easily updated. This was driven by the requirement to schedule IYA2009, which originally had 35 stations.
- The scheduling algorithm was tweaked. This typically results in 5-10% more observations, but fewer scans. There are fewer scans involving sub-nets, and more involving larger sub-nets.
- Schedulers can use either the IAU name or the common name when referring to a source. Previously if the schedule file contained a common name for a source, users would have to use it. *Sked* would not recognize the IAU name.
- A new option was added to the *flux* command. *Flux check* will return a list of sources that are missing fluxes. Previously users had to use *flux list* and visually check for sources with missing flux models.
- Recognition of new disk types: K5, Mark 5B, and Mark 5C
- Minor bug fixes and formatting changes.

Plans for the next year include: (1) updating documentation, (2) making VEX format native, and (3) supporting *CLEAN* components for source flux models.

#### 3.2. DRUDG

The only changes made to DRUDG were two bug fixes. Both of these surfaced under unusual circumstances and have not affected the normally scheduled IVS stations.

Plans for the next year include: (1) a documentation update and (2) support for new rack types.



### **3.3. Station Visits**

During this year there was one formal site visit. It was made to Ny-Ålesund. E. Himwich, R. Strand (NVI, Inc.), and B. Corey (MIT Haystack Observatory) visited the site to perform training, station evaluation, and computer upgrades. A detailed report of this activity, with recommendations for further work, was produced and sent to the station.

# Haystack Observatory Technology Development Center

*Chris Beaudoin, Brian Corey, Arthur Niell, Alan Whitney*

## Abstract

Technology development at MIT Haystack Observatory focused on three areas in 2009:

- a broadband, high-sensitivity receiver and data acquisition system to support VLBI2010 broadband delay observations
- the VLBI2010 prototype 12-m antenna system to be installed at GGAO
- improvement of data transfer over high speed fiber

## 1. The Broadband Delay Signal Chain

A proof-of-concept broadband signal chain has been designed and implemented by Haystack, with significant contributions from Honeywell Technology Solutions, Inc. The main components comprising the receiver front-end are displayed in Figure 1:

- Feed/LNAs in 20K Dewar
- Broadband phase and noise calibration
- RF over fiber transmitter

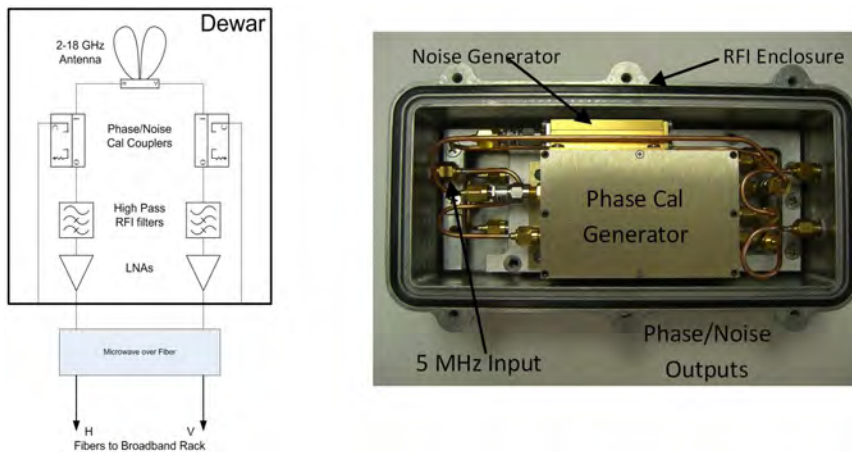

Figure 1. Main components of the receiver front-end: block diagram on the left; phase and noise calibration hardware on the right.

Many parts of the prototype front-end signal chain received attention this past year. Activities included:

- measurement of the antenna pattern of the Lindgren quadridge feed in the Dewar
- receipt and testing of a broadband Eleven feed from Chalmers
- enhancement of the new digital phase cal generator enclosure to reduce leakage to -180 dBm and to mitigate phase cal self-interference

The main components in the back-end are displayed in Figure 2 and Figure 3:

- Fiber receiver, amplifiers, and splitters (ORCA box)
- UpDown Converter (UDC) to select frequency bands
- Digital back-end (DBE) for digitization and filtering
- Mark 5B+ recorder

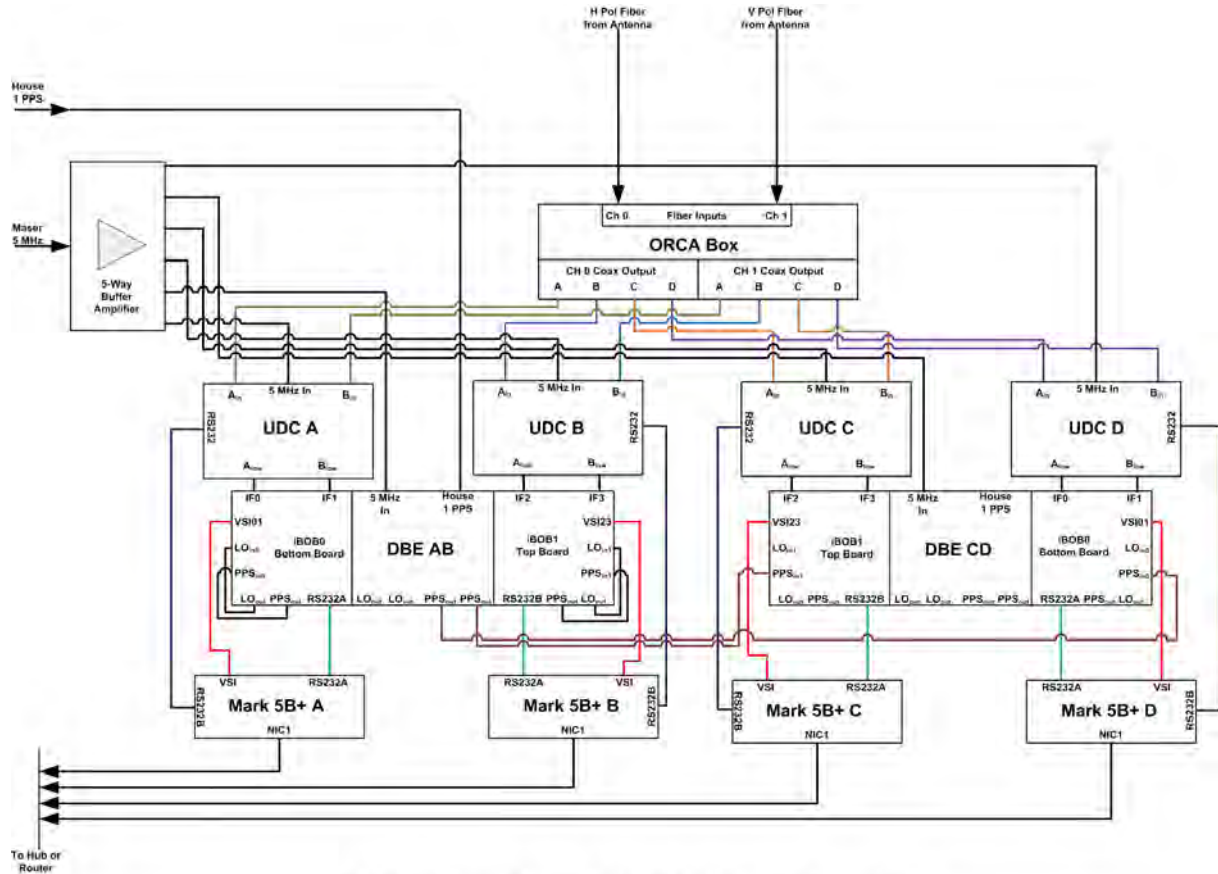

**BBD Multiband Rack Cable Routing Configuration**

Figure 2. Schematic of the receiver back-end

Progress has been made in the development of upgrades for the DBE and the Mark 5B+ recorder. The new DBE, designated RDBE, is being developed jointly with NRAO, while the Mark 5B+ recorder is being upgraded to Mark 5C with hardware modifications from Conduant Corp. The RDBE will have adjustable analog level control, automated digital channel gain, selection of output channels, and 10 GigE output. The Mark 5C will support 4 gigabit per second recording via 10 GigE input. In 2009 the polyphase filter bank was implemented in the FPGA code of the RDBE, data were transferred from the RDBE to the Mark 5C over the 10 GigE path, and auto-correlations were made of the data recorded on Mark 5 disk modules.

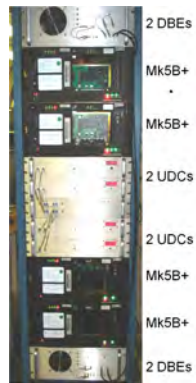

Figure 3. Photo of the receiver back-end hardware

## 2. Patriot 12-m Installation at GGAO

After implementing broadband proof-of-concept data acquisition systems on the Westford 18-m and GGAO 5-m antennas, a 12-m antenna was ordered with NASA funding and was delivered to GGAO. It is awaiting completion of the pad before assembly can continue.

## 3. Monitor and Control Infrastructure

Haystack began developing new monitor and control infrastructure (MCI) for the NASA Patriot 12-m antenna to be installed at GGAO, and a Google group has been established to centralize the development efforts. This MCI is being designed to meet the needs of the next generation VLBI2010 system and to further the initiative to enable remote, mostly unattended station operation. The GGAO 12-m MCI system initially will be composed of five separate nodes which will each collect data and provide control of the various components of the stations, as indicated in Figure 4. Data collected from each node will reside on a local backup repository.

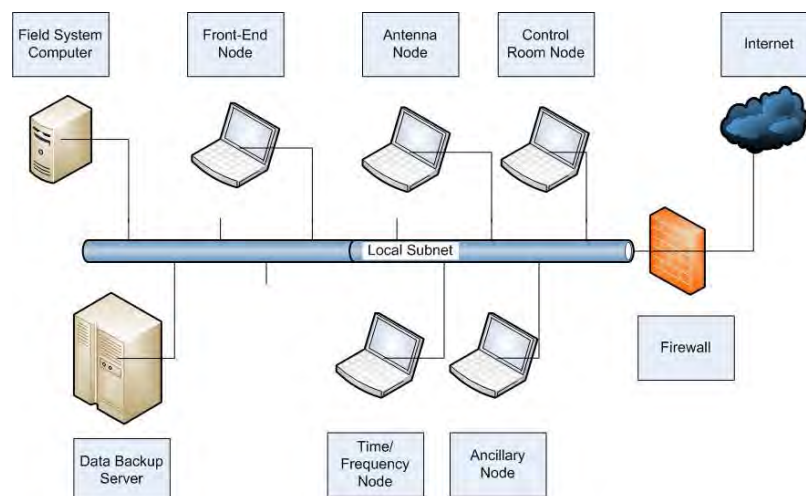

Figure 4. Network diagram of the 12-m monitor/control infrastructure

#### 4. GGOS Station Self-introduced RFI

In an effort to understand what problems might exist when co-locating instruments at a GGOS site, effective isotropic radiated power (EIRP) levels were measured from the SLR 9.4 GHz aircraft radar and from the 2 GHz DORIS beacon at GGAO. These levels are being compared to that which will introduce unacceptable RFI into the VLBI2010 system. A recommendation regarding the acceptable EIRP levels as observed by the VLBI2010 front-end from the DORIS beacon and the SLR radar transmitters is pending.

#### 5. e-VLBI Development

Haystack Observatory continues to support development for real-time e-VLBI and for e-VLBI data transfers. The main activities in 2009 were in e-transfer improvements.

- Improvements have been made in the automated transfer of VLBI data from Wettzell to USNO for the weekday Intensives.
- New connections: Haystack has been very active in helping to specify, support, and test new e-VLBI connections. Connection to the USNO correlator was implemented, but initially at a very low rate due to administrative problems. Work continues on completing the connection from the Kokee, Hawaii site to the DREN network which will provide access to the U.S. Testing has begun on the new connection to Fortaleza.
- Haystack has also been working with GSI and NICT personnel to improve e-transfers from Japanese K5-equipped sites. Data from all K5 sites are e-transferred and translated to Mark 5A or Mark 5B format. Recently the choice of format has been made at the destination correlator, after transfer of the data from GSI, in order to most closely match the complement of Mark 5A and Mark 5B playback systems at the correlator. The K5 e-transfers have been implemented and improved jointly with personnel at GSI and at Kashima.

#### 6. Acknowledgements

The broadband demonstration system is funded by NASA's Earth Surface and Interior Focus Area through the efforts of John LaBrecque, Chopo Ma, and Herb Frey.

Important contributions were made by Bruce Whittier, Mike Titus, Jason SooHoo, Dan Smythe, Chester Ruszczak, Alan Rogers, Jay Redmond, Mike Poirier, Arthur Niell, Russ Mewhirter, Chuck Kodak, Alan Hinton, Ed Himwich, Skip Gordon, Mark Evangelista, Irv Diegel, Brian Corey, and Tom Clark.

Sandy Weinreb and Hamdi Mani of Caltech have also continually supported developments of the broadband receiver through direct and e-mail correspondence on various topics regarding cryogenic microwave receiver front-ends. They have also provided hardware and test support through network measurements of the Eleven antenna received by Haystack and through custom modification of their LNAs to protect the broadband front-end from the high power transmitters at the Millstone Hill Observatory.

# Technology Development Center at NICT

*Kazuhiro Takefuji, Ryuichi Ichikawa, Mamoru Sekido*

## Abstract

National Institute of Information and Communications Technology (NICT) has led the development of the VLBI technique and has been highly active in both observations and technical developments. This report gives a review of the Technology Development Center (TDC) at NICT and summarizes recent activities.

## 1. TDC at NICT

National Institute of Information and Communications Technology (NICT) has published the newsletter “IVS NICT-TDC News (formerly IVS CRL-TDC News)” at least once a year in order to report on the development of VLBI related technology as an IVS technology development center. The newsletter is available through the Internet at the following URL: <http://www2.nict.go.jp/w/w114/stsi/ivstdc/news-index.html>.

## 2. Staff Members of NICT TDC

Table 1 lists the staff members at NICT who are involved in the VLBI technology development center at NICT.

Table 1. Staff Members of NICT TDC as of December, 2009 (alphabetical).

Name	Works
AMAGAI, Jun	K5/VSSP32, GPS analysis, TWSTFT <sup>1</sup>
HASEGAWA, Shingo	K5/VSSP32, K5/VSI
HOBIGER, Thomas	VLBI analysis, e-VLBI
ICHIKAWA, Ryuichi	MARBLE <sup>2</sup> system, Delta-VLBI, VLBI analysis
ISHII, Atsutoshi	MARBLE <sup>2</sup> system
KAWAI, Eiji	34 m and 11 m antenna system
KIMURA, Moritaka	Giga-bit system, K5/VSI, software correlator, e-VLBI
KONDO, Tetsuro <sup>3</sup>	K5/VSSP32, software correlator, e-VLBI
KOYAMA, Yasuhiro	e-VLBI, VLBI analysis
MIYAUCHI, Yuka	software correlator
SEKIDO, Mamoru	e-VLBI, Delta-VLBI, VLBI analysis
TAKEFUJI, Kazuhiro	e-VLBI
TAKIGUCHI, Hiroshi	VLBI analysis, e-VLBI, GPS analysis
TSUTSUMI, Masanori	K5 system, e-VLBI

<sup>1</sup> TWSTFT: Two-Way Satellite Time and Frequency Transfer

<sup>2</sup> MARBLE: Multiple Antenna Radio-interferometry of Baseline Length Evaluation

<sup>3</sup> On leave at Ajou University, Korea

### 3. Current Status and Activities

#### 3.1. e-VLBI

e-VLBI technology has been intensively developed in recent years. International e-VLBI experiments for ultra rapid UT1 measurements have been conducted as a pilot project for testing the operational stability of e-VLBI observation and correlation processing. A distributed correlation processing scheme has been developed and has been used for the rapid UT1 measurements [1]. A record of the minimum latency of UT1 measurement of less than 4 minutes was achieved on 22 February 2008 on the Tsukuba—Onsala baseline with a 256 Mbps data rate. The observation and correlation has been performed by Onsala and GSI. NICT has contributed to it by providing an automatic correlation system, automatic Mark III database creation via NetCDF<sup>1</sup> (MK3TOOLS [2]), and an automatic UT1 analysis scheme with OCCAM developed by T. Hobiger. Also we have participated in several e-VLBI demonstration events with the K5 data acquisition system (DAS). Flexibility in data format conversion is one of the important aspects of e-VLBI. We have developed a series of A/D converters for VLBI (ADS1000, ADS2000, and ADS3000), and they can be used for a variety of observation modes.

The Kashima 34 m telescope participated in the e-VLBI demonstration experiments for the opening ceremony of IYA (the International Year of Astronomy) conducted by JIVE in January 2009. We developed a Mark 5B emulator data sender for this event and adapted our K5/VSI system (see Figures 1 and 2) for the international e-VLBI experiment.



Figure 1. The ADS2000 can sample 16 baseband channels at the sampling rate of 64 Msps suitable for the bandwidth synthesis.



Figure 2. VSI-card can capture a high-rate data stream ( $\leq 2$  Gbps) through a VSI-H interface to a commodity PC.

#### 3.2. MARBLE – Contribution to VLBI2010

We are developing a compact VLBI system with a 1.6 m diameter aperture dish in order to provide reference baseline lengths for calibration. We named the system “Multiple Antenna Radio-interferometry for Baseline Length Evaluation (MARBLE)” [3]. On December 9, 2008, we installed the first prototype of the compact VLBI system on the top of the building near the Kashima 34 m antenna and successfully detected the first fringe between the first prototype of the compact VLBI system and the Kashima 34 m on February 9, 2009 [4]. Moreover, we installed the second prototype of the compact VLBI system at the Geographical Survey Institute (GSI),

<sup>1</sup><http://www.unidata.ucar.edu/software/netcdf/>

Tsukuba until the end of 2009. (See Figure 3.) We performed the first geodetic experiment using both prototypes on December 23, 2009, and we are now processing the obtained data sets.



Figure 3. The MARBLE compact VLBI system. The left panel shows the first prototype at Kashima, NICT, and the right panel shows the second one at Tsukuba, GSI.

### 3.3. ADS3000+ – Detected 4 GHz First Fringe!

NICT has been developing VLBI observation systems and data processing systems since the 1970s. The K5 VLBI system is designed with commodity products such as personal computers, hard disks, and network components. This strategy has been quite successful in developing flexible and high-performance observation systems and data processing systems for VLBI. Two independent series of systems, the K5/VSSP32 and the K5/VSI systems have been developed. The concept of the K5/VSSP32 systems is to develop A/D sampling units interfaced to commodity PC systems with USB2.0 interfaces with simultaneous 16 channel recordings. On the other hand, K5/VSI series are realized by high speed A/D sampler units and a commodity Linux PC system to record data with the VSI-H (VLBI Standard Interface - Hardware specifications).

Three high speed A/D sampler units, ADS1000, ADS2000, and ADS3000, have been developed to support various sampling modes. The next generation A/D sampler, which we called ADS3000+ and which supports up to 4 GHz sampling mode, is equipped with FPGA chips to realize a digital baseband converter (DBBC) and realtime RFI(CW) suppression.

A 4 Gsps (giga-samples per second) fringe test was performed on 27 April 2009 with ADS3000+ [7]. The Kashima 34 m antenna and the 11 m antenna were used. Both stations were set up with ADS3000+ with 4 GHz sampling mode. A target radio source was 3C273B. After being recorded with 1 bit quantization, the whole bandwidth spectrum of X-band is fully shown in Figure 4. A first fringe of 4 Gsps could be successfully detected after the correlation process, as shown in Figure 5. A signal-to-noise ratio (SNR) of the 3C273B fringe is estimated to be about 8.6 at 8 ms integration. The 4 Gsps fringe is the fastest record in NICT and IVS now.



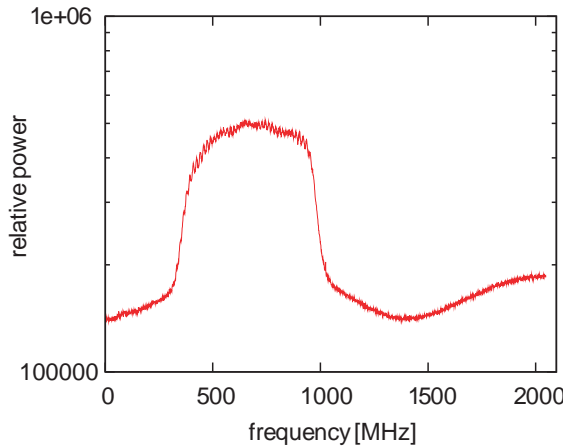

Figure 4. The spectrum of X-band at the Kashima 11 m antenna. The X-band bandwidth is 500 MHz wide; however, the 4 GHz sampling mode detects up to the Nyquist-rate, 2 GHz. The whole bandwidth spectrum of X-band can be obtained at one time.

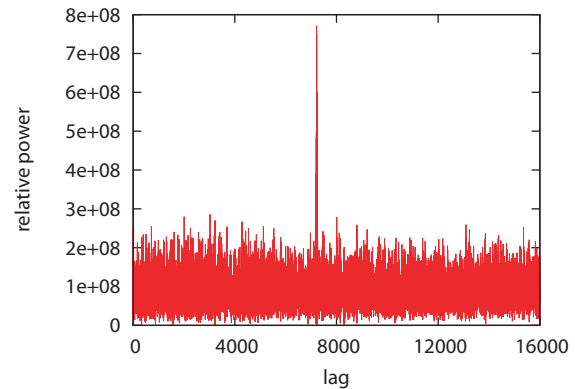

Figure 5. A first fringe of 3C273B at 4 GHz sampling speed with ADS3000+ in 8 ms integration time with the Kashima 34 m and 11 m antennas on 27 April 2009. The 4 Gsps fringe is the fastest record in NICT and IVS now.

#### 4. Future Plans

- Fringe test with digital baseband conversion of ADS3000+ (extraction 16 channels) to confirm compatibility with the K5/VSSP32 system.

#### References

- [1] Sekido M., M. Kimura, “VLBI Correlators in Kashima”, International VLBI Service for Geodesy and Astrometry 2009 Annual Report, edited by D. Behrend and K. D. Baver, this issue, 2010.
- [2] Hobiger, T. et al.: MK3TOOLS & NetCDF – storing VLBI data in a machine independent array oriented data format, Proceeding 18th European VLBI for Geodesy and Astrometry (EVGA) Working Meeting April 12, 2007, Vienna, Austria, <http://mars.hg.tuwien.ac.at/evga/>, P03, 2007.
- [3] Ichikawa R., A. Ishii, H. Takiguchi, H. Kuboki, M. Kimura, J. Nakajima, Y. Koyama, T. Kondo, M. Machida, S. Kurihara, K. Kokado, and S. Matsuzaka, Development of a Compact VLBI System for Providing over 10-km Baseline Calibration, “Measuring The Future”, Proc. of the Fifth IVS General Meeting, 400-404, 2008.
- [4] Ichikawa R., A. Ishii, H. Takiguchi, Y. Koyama, T. Kondo, K. Kokado, S. Kurihara, and S. Matsuzaka, Present Status and Outlook of Compact VLBI System Development for Providing over 10 km Baseline Calibration, *IVS NICT-TDC News* **No.30**, pp.22–25, October 2009.
- [5] Lindgren, ETS-Lindgren (2005). The Model 3164-05 Open Boundary Quadridge Horn, Data Sheet.
- [6] Koyama Y., T. Kondo, M. Sekido, and M. Kimura, Developments of K5/VSI System for Geodetic VLBI Observations, *IVS TDC News*, No. 29, pp.15-18, 2008.
- [7] Takefuji K., Koyama Y., Takeuchi H., First Fringe Detection with Next-Generation A/D Sampler ADS3000+, *IVS TDC News*, No. 30, pp.17-21, 2009.

## Onsala Space Observatory – IVS Technology Development Center

*Rüdiger Haas, Miroslav Pantaleev, Leif Helldner, Lars Pettersson, Hans-Georg Scherneck, Gunnar Elgered*

### Abstract

This report summarizes the technical development related to the geodetic VLBI activities that were performed at the Onsala Space Observatory during 2009. Most of the tasks planned for the year were addressed, and some new tasks were initiated. The focus was on:

- the development of a dual-polarized broadband Eleven feed for VLBI2010
- optical fiber tests for the transfer of VLBI IF-signals
- the new superconducting gravimeter
- the microwave radiometer Konrad
- the time and frequency laboratory

### 1. Development of a Cooled Version of an Eleven Feed for VLBI2010

During 2009 the project to develop a cooled version of an Eleven Feed [1] for VLBI2010 was continued. This project is headed now by Miroslav Pantaleev from the Electronics Lab at the Onsala Space Observatory (OSO). It is a collaboration of OSO, the Antenna Group at the Chalmers University of Technology, the Department of Microelectronics and Nanoscience at Chalmers, and the Hartebeesthoek Radio Observatory. Additional partners of the project are the California Institute of Technology and the Haystack Observatory.

The electrical, mechanical, and cryogenic design was continued, and five prototypes of the Eleven Feed were produced in 2009 at Onsala. The reflection coefficients of the feed at room temperature were measured both at Chalmers and at the California Institute of Technology. The measurement results agree very well with each other and with the design simulations (within 1–3 dB), and they are below –10 dB for the frequency range 2–13 GHz. The radiation pattern was measured at the Technical University of Denmark. Both directivity and radiation intensity agree well with the simulations (within 1 dB).

A prototype receiver cryostat was designed and built at OSO. The cryostat integrates the Eleven Feed together with LNAs at 20 K cryogenic temperature. A number of measurements were done with the cooled receiver to determine, for example, the reflection coefficient and the system noise. The reflection coefficient of the feed does not change when cooling, as compared to room temperature, and agrees within 1 dB with the design values. For the system noise measurements we used two-stage single-ended GaAs cryogenic HEMT amplifiers for the 4–8 GHz band. The measured average noise temperature over this band was 29 K. Similar tests were done at the Haystack observatory with single-ended InP HEMT amplifiers for the 2–12 GHz band, and the average noise temperature of this system was 18 K over the whole band and 20 K over the 4–8 GHz band. The results for the 4–8 GHz band are presented in Figure 2. The lower system noise measured at Haystack is due to the better LNAs used in their receiver.

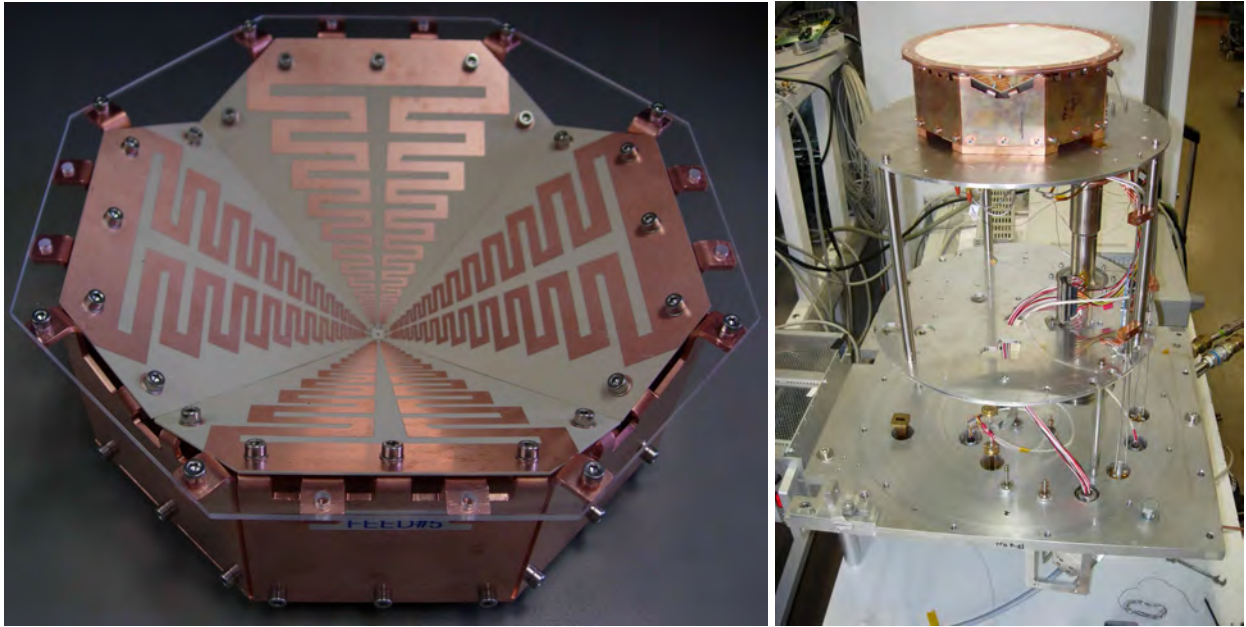

Figure 1. Left: One of the prototypes of the Eleven Feed for VLBI2010, built at the Onsala Space Observatory. Right: The feed prototype mounted on the cryostat.

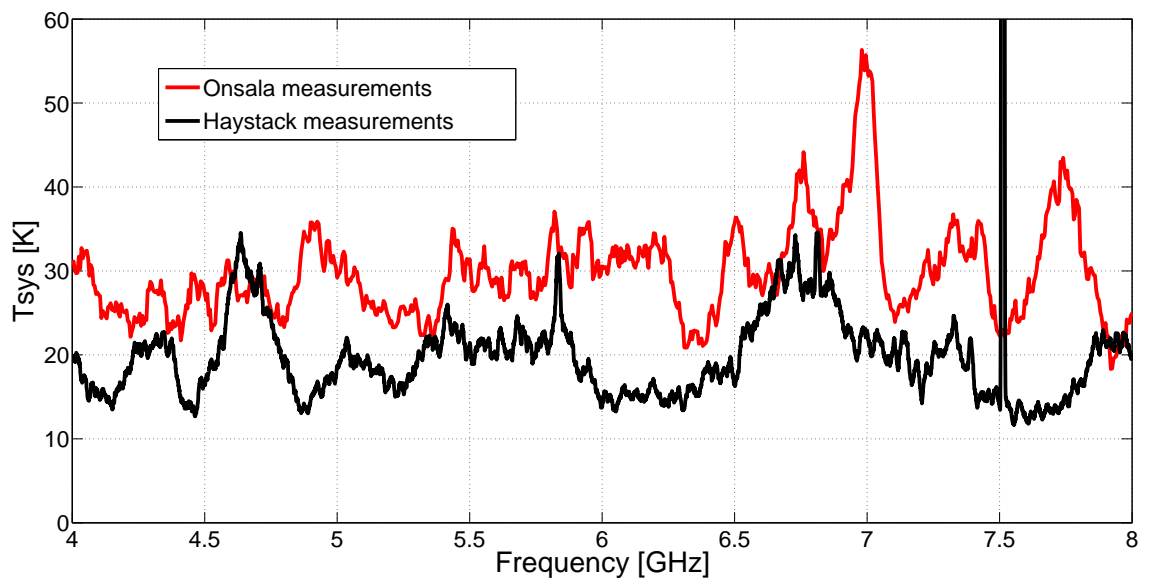

Figure 2. Comparison of the noise temperature measurements done at Haystack and at Onsala. A 15 point moving average is applied to the raw data. The mean values over the 4–8 GHz band are 20 K for the measurements at Haystack and 29 K for the measurements at Onsala.

## 2. Tests of an Analog Optical Fiber for the Transfer of VLBI IF-signals

The tests of optical fibers for the transfer of VLBI IF-signals [2] have continued, and the results have been summarized in a report [3]. The study shows that the fiber is temperature sensitive and that both the transmitter and the receiver of the optical fiber system need to be temperature controlled. Temperature changes do not influence the signal amplitude, but they influence the signal phase. Thus a phase-calibration system is necessary for VLBI operations. The fiber shows also a slight sensitivity to the elevation angle of the telescope, but no significant sensitivity to the azimuth angle. Based on these studies, it was decided to equip the 20-m telescope at Onsala with an analog optical fiber for frequencies up to 15 GHz.

## 3. The Superconducting Gravimeter at Onsala

In the spring of 2009 the new gravimeter house was completed and the superconducting gravimeter was finally installed in June 2009. Figure 3 shows the new gravimeter house and the instrument. Data have been recorded continuously since June 2009.



Figure 3. Left: The new gravimeter house at Onsala. Ground and surface water are collected, and the basin level is controlled by a pump. A barometer and a GPS time-receiver are located at the top of the new gravimeter house. Right: The new superconducting gravimeter “Hans” inside the gravimeter house.

#### 4. The Microwave Radiometer Konrad

The microwave radiometer Konrad [4] was maintained during 2009. The drive system was partly removed, and work to repair the instrument is still ongoing. We expect that the instrument can be taken into operation again in the summer of 2010.

#### 5. The Onsala Time and Frequency Laboratory

In 2009 the time and frequency laboratory at Onsala was equipped with a Cesium clock. Now it contains two H-masers, one Cesium clock, and several GPS timing receivers.

#### 6. Outlook and Future Plans

- During 2010 we will continue the development of a prototype Eleven Feed for VLBI2010. The plan is to integrate cryogenic differential LNAs into the feed. System noise tests will be done in 2010. A design study for the installation of the feed on the Onsala 20-m telescope during 2010 will be performed. In collaboration with the Microwave Electronics Laboratory at Chalmers, the integration of room temperature LNAs will also be prepared. Tests with broad band room temperature LNAs at one of the Onsala 2.5-m telescopes are planned.
- We plan to install an optical fiber covering frequencies up to 15 GHz on the 20-m telescope and to develop a corresponding calibration system.
- We will install the GNSS-based tide gauge at the Onsala Space Observatory and develop an automated data flow and analysis.
- We plan to install various sensors to monitor environmental parameters such as ground water at the new gravimeter house.
- We will try to develop the ability to read and monitor important parameters of the S/X-receiver directly with the FS.
- We will focus on an upgrade of the azimuth and elevation drives of the Konrad radiometer.

#### References

- [1] Olsson, R., Kildal, P.-S., and Weinreb, S.: The Eleven Antenna: A Compact Low-Profile Decade Bandwidth Dual Polarized Feed for Reflector Antennas, *IEEE Trans. Antennas and Propagation*, **54(2)**, 368–375, 2006.
- [2] Haas R, Helldner L, Pantaleev M, Löfgren J, Elgered G (2009) Onsala Space Observatory IVS Technology Development Center. In: *International VLBI Service for Geodesy and Astrometry 2008 Annual Report*, edited by D. Behrend and K. Baver, **NASA/TP-2009-214183**, 329–332.
- [3] Pettersson L (2009) Optical Fiber Tests. Internal report, Onsala Space Observatory, 36 pages.
- [4] Stoew, B., and Rieck, C.: Dual Channel Water Vapour Radiometer Development. In: W. Schlüter and H. Hase (Eds.): *Proceedings of the 13th Working Meeting on European VLBI for Geodesy and Astrometry*, 261–264, 1999.





## Bibliography



## Bibliography





## Bibliography

### 1. Introduction

The following bibliography compiles papers that were published in the field of geodetic and astrometric VLBI during the year 2009. There is no distinction between peer-reviewed, reviewed or proceedings publications. This list is by no means exhaustive.

### 2. Geodetic and Astrometric VLBI Publications of 2009

- O.B. ÅRDAL: “Ny-Ålesund 20-Meter Antenna”. In: International VLBI Service for Geodesy and Astrometry 2008 Annual Report, edited by D. Behrend and K. Baver, NASA/TP-2009-214183, 139–141, 2009.
- C. ABBONDANZA, Z. ALTAMIMI, P. SARTI, M. NEGUSINI, L. VITTUARI: “Local Effects of Redundant Terrestrial and GPS-based Tie Vectors in ITRF-like Combinations.” *Journal of Geodesy*, 83(11), 1031–1040, 2009.
- C. ABBONDANZA, L. VITTUARI, M. NEGUSINI, P. SARTI: “VLBI-GPS Eccentricity Vectors at Medicina’s Observatory via GPS Surveys: Reproducibility, Reliability and Quality Assessment of the Results.” In: *Geodetic Reference Frames*, edited by H. Drewes, IAG Symposia, 134, Springer-Verlag Berlin Heidelberg, 107–112, 2009.
- Y. AILI, X. LIU: “Nanshan VLBI Station Report for 2008”. In: International VLBI Service for Geodesy and Astrometry 2008 Annual Report, edited by D. Behrend and K. Baver, NASA/TP-2009-214183, 173–175, 2009.
- W. ALEF, H. ROTTMANN, D. GRAHAM, A. MÜSKENS, J. MORGAN, S. TINGAY, A. DELLER: “MPIfR/BKG Correlator Report”. In: *Proceedings of the 19th European VLBI for Geodesy and Astrometry Working Meeting*, edited by G. Bourda, P. Charlot, and A. Collioud, Université Bordeaux 1 – CNRS – Laboratoire d’Astrophysique de Bordeaux, 74–78, 2009.
- P.H. ANDERSEN: “FFI Analysis Center”. In: International VLBI Service for Geodesy and Astrometry 2008 Annual Report, edited by D. Behrend and K. Baver, NASA/TP-2009-214183, 259–260, 2009.
- P.H. ANDERSEN: “FFI Technology Development Center – Software Development”. In: International VLBI Service for Geodesy and Astrometry 2008 Annual Report, edited by D. Behrend and K. Baver, NASA/TP-2009-214183, 317, 2009.
- T. ARTZ, S. BÖCKMANN, A. NOTHNAGEL: “CONT08 – First Results and High Frequency Earth Rotation”. In: *Proceedings of the 19th European VLBI for Geodesy and Astrometry Working Meeting*, edited by G. Bourda, P. Charlot, and A. Collioud, Université Bordeaux 1 – CNRS – Laboratoire d’Astrophysique de Bordeaux, 111–115, 2009.
- C. BARACHE: “Paris Observatory (OPAR) Data Center”. In: International VLBI Service for Geodesy and Astrometry 2008 Annual Report, edited by D. Behrend and K. Baver, NASA/TP-2009-214183, 236–238, 2009.
- C. BARACHE, S. BOUQUILLON, J. SOUCHAY, A. ANDREI, F. TARIS, A.-M. GONTIER, S. LAMBERT, E. ARIAS, C. LE PONCIN-LAFITTE: “The Construction of the Large Quasar Astromet-

- ric Catalogue (LQAC)”. In: Proceedings of Semaine de l’Astrophysique Française – Journées de la SF2A 2009, edited by M. Heydari-Malayeri, C. Reylé, and R. Samadi, Société Française d’Astronomie & d’Astrophysique, 93–96, 2009.  
<http://sf2a.cesr.fr/2009/2009sf2a.conf..0093B.pdf>
- A. BAUDRY: “VLBI Potential of the ALMA Telescope in the Millimetre”. In: Proceedings of the 19th European VLBI for Geodesy and Astrometry Working Meeting, edited by G. Bourda, P. Charlot, and A. Collioud, Université Bordeaux 1 – CNRS – Laboratoire d’Astrophysique de Bordeaux, 165–168, 2009.
- D. BEHREND: “Coordinating Center Report”. In: International VLBI Service for Geodesy and Astrometry 2008 Annual Report, edited by D. Behrend and K. Baver, NASA/TP-2009-214183, 77–79, 2009.
- S. BERNHART, A. BERTARINI, A. MÜSKENS, W. ALEF: “The Bonn Astro/Geo Mark IV Correlator”. In: International VLBI Service for Geodesy and Astrometry 2008 Annual Report, edited by D. Behrend and K. Baver, NASA/TP-2009-214183, 201–204, 2009.
- A. BERTARINI, A. NOTHNAGEL, B. COREY, R.C. WALKER, W. ALEF: “Measurements of the Polarization Leakage and their Effects on the Geodetic-VLBI Observables”. In: Proceedings of the 19th European VLBI for Geodesy and Astrometry Working Meeting, edited by G. Bourda, P. Charlot, and A. Collioud, Université Bordeaux 1 – CNRS – Laboratoire d’Astrophysique de Bordeaux, 58–62, 2009.
- G. BIANCO, G. COLUCCI, F. SCHIAVONE: “Matera CGS VLBI Station”. In: International VLBI Service for Geodesy and Astrometry 2008 Annual Report, edited by D. Behrend and K. Baver, NASA/TP-2009-214183, 126–129, 2009.
- D. BOBOLTZ, A. FEY, J. BARTLETT, Z. DUGAN, K. KINGHAM, D. HALL: “U.S. Naval Observatory VLBI Analysis Center”. In: International VLBI Service for Geodesy and Astrometry 2008 Annual Report, edited by D. Behrend and K. Baver, NASA/TP-2009-214183, 305–308, 2009.
- S. BÖCKMANN, T. ARTZ, A. NOTHNAGEL: “IVS Contribution to ITRF2008 – Status & Results”. In: Proceedings of the 19th European VLBI for Geodesy and Astrometry Working Meeting, edited by G. Bourda, P. Charlot, and A. Collioud, Université Bordeaux 1 – CNRS – Laboratoire d’Astrophysique de Bordeaux, 102–106, 2009.
- J. BÖHM, R. HEINKELMANN, P. MENDES CERVEIRA, A. PANY, H. SCHUH: “Atmospheric Loading Corrections at the Observation Level in VLBI Analysis”. *Journal of Geodesy*, 83(11), 1107–1113, 2009.
- J. BÖHM, R. HEINKELMANN, H. SCHUH: “Neutral Atmosphere Delays: Empirical Models versus Discrete Time Series from Numerical Weather Models.” In: *Geodetic Reference Frames*, edited by H. Drewes, IAG Symposia, 134, Springer-Verlag Berlin Heidelberg, 317–321, 2009.
- J. BÖHM, J. KOUBA, H. SCHUH: “Forecast Vienna Mapping Functions 1 for Real-time Analysis of Space Geodetic Observations”. *Journal of Geodesy*, 83(5), 397–401, 2009.
- J. BÖHM, H. SPICAKOVA, L. PLANK, A. PANY, J. WRESNIK, S. ENGLISH, T. NILSSON, H. SCHUH, T. HOBIGER, R. ICHIKAWA, Y. KOYAMA, T. GOTOH, T. KUBOOKA, T. OTSUBO: “Plans for the Vienna VLBI Software VieVS”. In: Proceedings of the 19th European VLBI for Geodesy and Astrometry Working Meeting, edited by G. Bourda, P. Charlot, and A. Collioud, Université Bordeaux 1 – CNRS – Laboratoire d’Astrophysique de Bordeaux, 161–164, 2009.
- S. BOLOTIN, S. LYTVYN, Y. YATSKIV: “IVS Analysis Center at Main Astronomical Observatory

- of National Academy of Sciences of Ukraine”. In: International VLBI Service for Geodesy and Astrometry 2008 Annual Report, edited by D. Behrend and K. Baver, NASA/TP-2009-214183, 285–286, 2009.
- G. BOURDA, A. BELLANGER, P. CHARLOT, A. COLLIOUD, M. ZHANG, A. BAUDRY: “Bordeaux IVS Analysis Center: Activities and Future Plans”. In: Proceedings of the 19th European VLBI for Geodesy and Astrometry Working Meeting, edited by G. Bourda, P. Charlot, and A. Collioud, Université Bordeaux 1 – CNRS – Laboratoire d’Astrophysique de Bordeaux, 173–176, 2009.
- R. CAMPBELL, A. SZOMORU: “e-VLBI and Other Developments at the EVN MkIV Data Processor at JIVE”. In: Proceedings of the 19th European VLBI for Geodesy and Astrometry Working Meeting, edited by G. Bourda, P. Charlot, and A. Collioud, Université Bordeaux 1 – CNRS – Laboratoire d’Astrophysique de Bordeaux, 79–83, 2009.
- N. CAPITAINE, P.M. MATTHEWS, V. DEHANT, P. WALLACE, S. LAMBERT: “On the IAU 2000/2006 Precession-nutation and Comparison with Other Models and VLBI Observations”. *Celest. Mech. Dyn. Astr.*, 103, 179–190, 2009.
- P. CHARLOT, A. BELLANGER, G. BOURDA, A. COLLIOUD, M. ZHANG, A. BAUDRY: “Bordeaux Observatory Analysis Center Report”. In: International VLBI Service for Geodesy and Astrometry 2008 Annual Report, edited by D. Behrend and K. Baver, NASA/TP-2009-214183, 246–249, 2009.
- J. CHO, Y. KWAK: “KASI Combination Center Report”. In: International VLBI Service for Geodesy and Astrometry 2008 Annual Report, edited by D. Behrend and K. Baver, NASA/TP-2009-214183, 283–284, 2009.
- A. COLLIOUD, P. CHARLOT: “The Bordeaux VLBI Image Database”. In: Proceedings of the 19th European VLBI for Geodesy and Astrometry Working Meeting, edited by G. Bourda, P. Charlot, and A. Collioud, Université Bordeaux 1 – CNRS – Laboratoire d’Astrophysique de Bordeaux, 19–22, 2009.
- F. COLOMER, P. DE VICENTE, J. GÓMEZ–GONZÁLEZ, J.A. LÓPEZ–FERNÁNDEZ, S. GARCÍA ESPADA: “Observatorio Astronómico Nacional of Spain”. In: International VLBI Service for Geodesy and Astrometry 2008 Annual Report, edited by D. Behrend and K. Baver, NASA/TP-2009-214183, 184–187, 2009.
- L. COMBRINCK, M. NICKOLA: “Hartebeesthoek Radio Astronomy Observatory (HartRAO)”. In: International VLBI Service for Geodesy and Astrometry 2008 Annual Report, edited by D. Behrend and K. Baver, NASA/TP-2009-214183, 107–110, 2009.
- F. DELEFLIE, S. LAMBERT, X. COLLILIEUX, C. BARACHE, J. BERTHIER, O. LAURAIN, D. COULOT, P. EXERTIER, A.-M. GONTIER: “The Virtual Observatory in Geodesy and Earth’s Sciences: the French Activities”. In: Proceedings of the 16th International Workshop on Laser Ranging, edited by S. Schillak, Space Research Centre, Polish Academy of Sciences, 193–198, 2009.
- K. DOI, K. SHIBUYA, Y. AOYAMA: “JARE Syowa Station 11-m Antenna, Antarctica”. In: International VLBI Service for Geodesy and Astrometry 2008 Annual Report, edited by D. Behrend and K. Baver, NASA/TP-2009-214183, 161–164, 2009.
- A. DYAKOV, S. SMOLENTSEV: “Zelenchukskaya Radio Astronomical Observatory”. In: International VLBI Service for Geodesy and Astrometry 2008 Annual Report, edited by D. Behrend and K. Baver, NASA/TP-2009-214183, 188–190, 2009.

- G. ELGERED, R. HAAS, T. NILSSON: “Atmospheric VLBI: A Method to Validate Long Time Series of Water Vapour Content”. In: Proceedings of the 19th European VLBI for Geodesy and Astrometry Working Meeting, edited by G. Bourda, P. Charlot, and A. Collioud, Université Bordeaux 1 – CNRS – Laboratoire d’Astrophysique de Bordeaux, 49–53, 2009.
- S. ENGLICH, H. SCHUH: “Models for High Accurate Space Geodetic Observations”. In: Proceedings of the “Journées 2008 Systèmes de référence spatio-temporels”, edited by M. Soffel and N. Capitaine, Lohrmann-Observatorium and Observatoire de Paris, 9–13, 2009.
- S. ENGLICH, H. SCHUH, R. HEINKELMANN: “Direct Estimation of Tidally Induced Earth Rotation Variations Observed by VLBI”. In: Proceedings of the “Journées 2008 Systèmes de référence spatio-temporels”, edited by M. Soffel and N. Capitaine, Lohrmann-Observatorium and Observatoire de Paris, 137–138, 2009.
- A. FEY, D. BOBOLTZ, R. OJHA, R. GAUME, K. KINGHAM: “USNO Analysis Center for Source Structure Report”. In: International VLBI Service for Geodesy and Astrometry 2008 Annual Report, edited by D. Behrend and K. Baver, NASA/TP-2009-214183, 309–311, 2009.
- A. FEY, D. GORDON, C. JACOBS (EDS.): “The Second Realization of the International Celestial Reference Frame by Very Long Baseline Interferometry”. Presented on behalf of the IERS/IVS Working Group. IERS Technical Note, No. 35, Verlag des Bundesamts für Kartographie und Geodäsie, Frankfurt am Main, ISBN 3-89888-918-6, 204 pp., 2009.
- R. GAUME, J. SOUCHAY, A. ANDREI, E. ARIAS, C. BARACHE, D. BOBOLTZ, S. BOUQUILLON, J. CHAPRONT, A. FEY, A. FIENGA, G. FRANCOU, A.-M. GONTIER, S. LAMBERT, C. LE PONCIN-LAFITTE, F. TARIS, N. ZACHARIAS: “ICRS Center”. In: International Earth Rotation and Reference Systems Service (IERS) 2007 Annual Report, edited by W. Dick and B. Richter, Verlag des Bundesamtes für Kartographie und Geodäsie, Frankfurt am Main, ISBN 978-3-89888-917-9, 82, 2009.
- J. GÓMEZ-GONZÁLEZ, F. COLOMER, J.A. LÓPEZ-FERNÁNDEZ: “An Atlantic Network of Geodynamical and Space Stations (Project RAEGE)”. In: Proceedings of the 19th European VLBI for Geodesy and Astrometry Working Meeting, edited by G. Bourda, P. Charlot, and A. Collioud, Université Bordeaux 1 – CNRS – Laboratoire d’Astrophysique de Bordeaux, 133–136, 2009.
- A.-M. GONTIER, S. LAMBERT, C. BARACHE: “Paris Observatory Analysis Center OPAR: Report on Activities, January–December 2008”. In: International VLBI Service for Geodesy and Astrometry 2008 Annual Report, edited by D. Behrend and K. Baver, NASA/TP-2009-214183, 291–294, 2009.
- A.-M. GONTIER, S. LAMBERT, C. BARACHE: “VLBI at OPAR: Analysis Service and Research”. In: Proceedings of the 19th European VLBI for Geodesy and Astrometry Working Meeting, edited by G. Bourda, P. Charlot, and A. Collioud, Université Bordeaux 1 – CNRS – Laboratoire d’Astrophysique de Bordeaux, 177–179, 2009.
- D. GAMBIS, C. BIZOUARD: “Monitoring UT1 using both VLBI and GPS Estimates”. In: Proceedings of the 19th European VLBI for Geodesy and Astrometry Working Meeting, edited by G. Bourda, P. Charlot, and A. Collioud, Université Bordeaux 1 – CNRS – Laboratoire d’Astrophysique de Bordeaux, 107–110, 2009.
- S. GARCÍA-ESPADA, F. COLOMER, R. HAAS: “Simulations of Different Antenna Velocities in VLBI Networks”. In: Proceedings of the 19th European VLBI for Geodesy and Astrometry

- Working Meeting, edited by G. Bourda, P. Charlot, and A. Collioud, Université Bordeaux 1 – CNRS – Laboratoire d’Astrophysique de Bordeaux, 169–172, 2009.
- D. GORDON, C. MA, D. MACMILLAN, J. GIPSON, K. BAVER: “GSFC VLBI Analysis Center”. In: International VLBI Service for Geodesy and Astrometry 2008 Annual Report, edited by D. Behrend and K. Baver, NASA/TP-2009-214183, 265–268, 2009.
- D. GORDON, D. MACMILLAN: “Preparations for the Next ICRF: Work at GSFC”. In: Proceedings of the 19th European VLBI for Geodesy and Astrometry Working Meeting, edited by G. Bourda, P. Charlot, and A. Collioud, Université Bordeaux 1 – CNRS – Laboratoire d’Astrophysique de Bordeaux, 1–4, 2009.
- T. GOTOH, T. HOBIGER, J. AMAGAI, Y. KOYAMA, T. KONDO: “Development of a GPS Software Receiver Based on K5/VSSP and a GPU”. IVS NICT Technology Development Center News, No. 30, ISSN 1882-3432, 3–5, October 2009.
- S. GULYAEV, T. NATUSCH: “New Zealand 12-m VLBI Station for Geodesy and Astronomy”. In: International VLBI Service for Geodesy and Astrometry 2008 Annual Report, edited by D. Behrend and K. Baver, NASA/TP-2009-214183, 68–73, 2009.
- R. HAAS, G. ELGERED: “Onsala Space Observatory – IVS Network Station”. In: International VLBI Service for Geodesy and Astrometry 2008 Annual Report, edited by D. Behrend and K. Baver, NASA/TP-2009-214183, 146–149, 2009.
- R. HAAS, L. HELLDNER, M. PANTALEEV, J. LÖFGREN, G. ELGERED: “Onsala Space Observatory – IVS Technology Development Center”. In: International VLBI Service for Geodesy and Astrometry 2008 Annual Report, edited by D. Behrend and K. Baver, NASA/TP-2009-214183, 329–332, 2009.
- R. HAAS, H.-G. SCHERNECK, T. NILSSON: “Onsala Space Observatory – IVS Analysis Center”. In: International VLBI Service for Geodesy and Astrometry 2008 Annual Report, edited by D. Behrend and K. Baver, NASA/TP-2009-214183, 295–298, 2009.
- H. HASE, R. DASSING, G. KRONSNABL, T. KLÜGEL, C. PLÖTZ, A. NEIDHARDT, P. LAUBER, R. KILGER: “Status of the Twin Telescope Wettzell Project”. In: Proceedings of the 19th European VLBI for Geodesy and Astrometry Working Meeting, edited by G. Bourda, P. Charlot, and A. Collioud, Université Bordeaux 1 – CNRS – Laboratoire d’Astrophysique de Bordeaux, 127–132, 2009.
- R. HEINKELMANN: “IVSTrop: Status and Recommendations of the IVS Rapid Troposphere Combination”. In: Proceedings of the 19th European VLBI for Geodesy and Astrometry Working Meeting, edited by G. Bourda, P. Charlot, and A. Collioud, Université Bordeaux 1 – CNRS – Laboratoire d’Astrophysique de Bordeaux, 180–182, 2009.
- E. HIMWICH: “Network Coordinator Report”. In: International VLBI Service for Geodesy and Astrometry 2008 Annual Report, edited by D. Behrend and K. Baver, NASA/TP-2009-214183, 83–88, 2009.
- E. HIMWICH, J. GIPSON: “GSFC Technology Development Center Report”. In: International VLBI Service for Geodesy and Astrometry 2008 Annual Report, edited by D. Behrend and K. Baver, NASA/TP-2009-214183, 318–320, 2009.
- T. HOBIGER, R. ICHIKAWA, Y. KOYAMA, T. KONDO: “Accelerating the Computation of Ray-traced Troposphere Delays by GPUs”. IVS NICT Technology Development Center News, No. 30, ISSN 1882-3432, 6–8, October 2009.

- T. HOBIGER, H. TAKIGUCHI, R. ICHIKAWA, M. SEKIDO, Y. KOYAMA, T. KONDO: “Analysis Center at National Institute of Information and Communications Technology”. In: International VLBI Service for Geodesy and Astrometry 2008 Annual Report, edited by D. Behrend and K. Baver, NASA/TP-2009-214183, 287–290, 2009.
- X. HONG, Q. FAN, T. AN: “Sheshan VLBI Station Report for 2008”. In: International VLBI Service for Geodesy and Astrometry 2008 Annual Report, edited by D. Behrend and K. Baver, NASA/TP-2009-214183, 150–153, 2009.
- R. ICHIKAWA: “Kashima 34m Antenna 20th Anniversary”. IVS NICT Technology Development Center News, No. 30, ISSN 1882-3432, 36, October 2009.
- R. ICHIKAWA, A. ISHII, H. TAKIGUCHI, Y. KOYAMA, T. KONDO, K. KOKADO, S. KURIHARA, S. MATSUZAKA: “Present Status and Outlook of Compact VLBI System Development for Providing over 10km Baseline Calibration”. IVS NICT Technology Development Center News, No. 30, ISSN 1882-3432, 22–25, October 2009.
- A. ISHII, R. ICHIKAWA, H. TAKIGUCHI, K. TAKEFUJI, Y. KOYAMA, S. KURIHARA, K. KOKADO, D. TANIMOTO: “Geodetic VLBI Experiments by a Small VLBI Antenna with a Broad-band Feed”. IVS NICT Technology Development Center News, No. 30, ISSN 1882-3432, 30–32, October 2009.
- C. JACOBS: “JPL VLBI Analysis Center Report for 2008”. In: International VLBI Service for Geodesy and Astrometry 2008 Annual Report, edited by D. Behrend and K. Baver, NASA/TP-2009-214183, 279–282, 2009.
- C. JACOBS, O. SOVERS: “X/Ka-band Global Astrometric Results”. In: Proceedings of the 19th European VLBI for Geodesy and Astrometry Working Meeting, edited by G. Bourda, P. Charlot, and A. Collioud, Université Bordeaux 1 – CNRS – Laboratoire d’Astrophysique de Bordeaux, 9–13, 2009.
- T. JIKE, S. MANABE, Y. TAMURA, M. SHIZUGAMI, VERA GROUP: “VERA Geodetic Activities”. In: International VLBI Service for Geodesy and Astrometry 2008 Annual Report, edited by D. Behrend and K. Baver, NASA/TP-2009-214183, 132–135, 2009.
- P. KAUFMANN, A.M. PEREIRA DE LUCENA, A. SOMBRA DA SILVA, C.E. TATEYAMA, A. FILHO, C.F.B. MOREIRA: “Fortaleza Station Report for 2007”. In: International VLBI Service for Geodesy and Astrometry 2008 Annual Report, edited by D. Behrend and K. Baver, NASA/TP-2009-214183, 99–102, 2009.
- E. KAWAI, M. SEKIDO, R. ICHIKAWA: “Kashima 34-m Radio Telescope”. In: International VLBI Service for Geodesy and Astrometry 2008 Annual Report, edited by D. Behrend and K. Baver, NASA/TP-2009-214183, 114–117, 2009.
- K. KIM: “Kokee Park Geophysical Observatory”. In: International VLBI Service for Geodesy and Astrometry 2008 Annual Report, edited by D. Behrend and K. Baver, NASA/TP-2009-214183, 122–125, 2009.
- K. KINGHAM, M.S. CARTER: “NEOS Operation Center”. In: International VLBI Service for Geodesy and Astrometry 2008 Annual Report, edited by D. Behrend and K. Baver, NASA/TP-2009-214183, 198, 2009.
- K. KINGHAM, D. HALL: “Washington Correlator”. In: International VLBI Service for Geodesy and Astrometry 2008 Annual Report, edited by D. Behrend and K. Baver, NASA/TP-2009-214183, 220–222, 2009.

- Y. KOYAMA: “Kashima and Koganei 11-m VLBI Stations”. In: International VLBI Service for Geodesy and Astrometry 2008 Annual Report, edited by D. Behrend and K. Baver, NASA/TP-2009-214183, 118–121, 2009.
- Y. KOYAMA: “Technical Developments Towards VLBI2010”. IVS NICT Technology Development Center News, No. 30, ISSN 1882-3432, 9–12, October 2009.
- Y. KOYAMA, M. SEKIDO, H. TAKIGUCHI: “Data Center at NICT”. In: International VLBI Service for Geodesy and Astrometry 2008 Annual Report, edited by D. Behrend and K. Baver, NASA/TP-2009-214183, 232–235, 2009.
- S. KURDUBOV, N. PANAFIDINA: “Scale Difference between Various TRF Solutions”. In: Proceedings of the 19th European VLBI for Geodesy and Astrometry Working Meeting, edited by G. Bourda, P. Charlot, and A. Collioud, Université Bordeaux 1 – CNRS – Laboratoire d’Astrophysique de Bordeaux, 23–26, 2009.
- S. KURDUBOV, E. SKURIKHINA: “Dependence of Catalogue Orientation Parameters Accuracy from Sources Set Selection”. In: Proceedings of the 19th European VLBI for Geodesy and Astrometry Working Meeting, edited by G. Bourda, P. Charlot, and A. Collioud, Université Bordeaux 1 – CNRS – Laboratoire d’Astrophysique de Bordeaux, 5–8, 2009.
- S. KURIHARA, K. KOKADO: “Ultra-Rapid UT1 Experiment using e-VLBI Technique”. Bulletin of the Geographical Survey Institute, 57, 35–43, 2009.
- S. LAMBERT, A.-M. GONTIER: “On Radio Source Selection to Define a Stable Celestial Frame”. *Astron. Astrophys.*, 493, 317–323, 2009.
- S. LAMBERT, A.-M. GONTIER: “On Radio Source Selection and Frame Stability”. In: Proceedings of the 19th European VLBI for Geodesy and Astrometry Working Meeting, edited by G. Bourda, P. Charlot, and A. Collioud, Université Bordeaux 1 – CNRS – Laboratoire d’Astrophysique de Bordeaux, 27–29, 2009.
- S. LAMBERT, C. LE PONCIN-LAFITTE: “Determining the Relativistic Parameter  $\gamma$  using Very Long Baseline Interferometry”. *Astron. Astrophys.*, 499, 331–335, 2009.
- R. LANOTTE, G. BIANCO: “Matera CGS VLBI Analysis Center”. In: International VLBI Service for Geodesy and Astrometry 2008 Annual Report, edited by D. Behrend and K. Baver, NASA/TP-2009-214183, 253–254, 2009.
- J. LI: “SHAO Analysis Center 2008 Annual Report”. In: International VLBI Service for Geodesy and Astrometry 2008 Annual Report, edited by D. Behrend and K. Baver, NASA/TP-2009-214183, 302–304, 2009.
- M. LÖSLER, C. ESCHELBACH: “Evolution and Obtained Expertise in Reference Point Determination at the GIK”. In: Proceedings of the 19th European VLBI for Geodesy and Astrometry Working Meeting, edited by G. Bourda, P. Charlot, and A. Collioud, Université Bordeaux 1 – CNRS – Laboratoire d’Astrophysique de Bordeaux, 116–121, 2009.
- M. LÖSLER, R. HAAS: “The 2008 Local-tie Survey at the Onsala Space Observatory”. In: Proceedings of the 19th European VLBI for Geodesy and Astrometry Working Meeting, edited by G. Bourda, P. Charlot, and A. Collioud, Université Bordeaux 1 – CNRS – Laboratoire d’Astrophysique de Bordeaux, 97–101, 2009.
- J. LOVELL, J. DICKEY, B. REID, S. ELLINGSEN: “Hobart, Mt. Pleasant, Station Report for 2008”. In: International VLBI Service for Geodesy and Astrometry 2008 Annual Report, edited

- by D. Behrend and K. Baver, NASA/TP-2009-214183, 111–113, 2009.
- V. L'VOV, Z. MALKIN, S. TSEKMEISTER: “Forthcoming Close Approaches of Jupiter and Saturn to Geodetic Radio Sources”. In: Proceedings of the “Journées 2008 Systèmes de référence spatio-temporels”, edited by M. Soffel and N. Capitaine, Lohrmann-Observatorium and Observatoire de Paris, 237–238, 2009.
- D. MACMILLAN, J. GIPSON: “Recent Modeling Improvements in SOLVE Analysis”. In: Proceedings of the 19th European VLBI for Geodesy and Astrometry Working Meeting, edited by G. Bourda, P. Charlot, and A. Collioud, Université Bordeaux 1 – CNRS – Laboratoire d’Astrophysique de Bordeaux, 54–57, 2009.
- Z. MALKIN: “On Comparison of the Earth Orientation Parameters Obtained from Different VLBI Networks and Observing Programs”. *Journal of Geodesy*, 83(6), 547–556, 2009.
- Z. MALKIN: “Radioastrometry”. In: Today’s Astronomy Researches in Pulkovo. A.V. Stepanov (ed.), St. Petersburg, 320–333, 2009. (in Russian)
- Z. MALKIN: “ICRF – The Recent Status and Near Prospects”. In: Proceedings of the All-Russian Astrometry Conference “Pulkovo-2009”, *Izvestiya GAO*, 219(4), St. Petersburg, 189–194, 2009. (in Russian)
- Z. MALKIN: “Applications of Allan Variance and its Modifications to Investigations of Time Series”. In: Proceedings of the All-Russian Astrometry Conference “Pulkovo-2009”, *Izvestiya GAO*, 219(4), St. Petersburg, 195–198, 2009. (in Russian)
- Z. MALKIN: “VLBI2010 Project”. In: Proceedings of the All-Russian Astrometry Conference “Pulkovo-2009”, *Izvestiya GAO*, 219(4), St. Petersburg, 199–204, 2009. (in Russian)
- Z. MALKIN: “A Comparison of Empiric Free Core Nutation Models”. In: Proceedings of the All-Russian Astrometry Conference “Pulkovo-2009”, *Izvestiya GAO*, 219(4), St. Petersburg, 205–210, 2009. (in Russian)
- Z. MALKIN, V. L'VOV, S. TSEKMEISTER: “Forthcoming Close Angular Approaches of Planets to Radio Sources and Possibilities to Use Them as GR Tests”. *Solar System Research*, 43(4), 313–318, 2009.
- Z. MALKIN, N. MILLER, J. SOKOLOVA, E. POPOVA: “Pulkovo IVS Analysis Center (PUL) 2008 Report”. In: International VLBI Service for Geodesy and Astrometry 2008 Annual Report, edited by D. Behrend and K. Baver, NASA/TP-2009-214183, 299–301, 2009.
- Z. MALKIN, E. POPOVA: “An Analysis of Source Motions Derived from Position Time Series”. In: Proceedings of the “Journées 2008 Systèmes de référence spatio-temporels”, edited by M. Soffel and N. Capitaine, Lohrmann-Observatorium and Observatoire de Paris, 239–240, 2009.
- P. MENDES CERVEIRA, J. BÖHM, H. SCHUH, T. KLÜGEL, A. VELIKOSELTSEV, U. SCHREIBER, A. BRZEZINSKI “Earth Rotation Observed by Very Long Baseline Interferometry and Ring Laser”. *Pure Applied Geophysics*, 166(6-8), 1499–1517, 2009.
- M. NANNI, F. MANTOVANI: “The Network Infrastructure for Radio Astronomy in Italy”. In: Proceedings of the 8th International e-VLBI Workshop (EXPreS09), Proceedings of Science (PoS), PoS(EXPreS09)033, 6 p., 2009.  
[http://pos.sissa.it/archive/conferences/082/033/EXPreS09\\_033.pdf](http://pos.sissa.it/archive/conferences/082/033/EXPreS09_033.pdf)
- M. NEGUSINI, P. SARTI, C. ABBONDANZA: “Italy INAF Data Center Report”. In: International VLBI Service for Geodesy and Astrometry 2008 Annual Report, edited by D. Behrend and K.



- Baver, NASA/TP-2009-214183, 230–231, 2009.
- M. NEGUSINI, P. SARTI, C. ABBONDANZA: “Italy INAF Analysis Center Report”. In: International VLBI Service for Geodesy and Astrometry 2008 Annual Report, edited by D. Behrend and K. Baver, NASA/TP-2009-214183, 277–278, 2009.
- M. NEGUSINI, P. SARTI, C. ABBONDANZA: “Geodetic Research at IRA-INAF: Recent Results between a Golden Past and a Gloomy Future”. In: Proceedings of the 19th European VLBI for Geodesy and Astrometry Working Meeting, edited by G. Bourda, P. Charlot, and A. Collioud, Université Bordeaux 1 – CNRS – Laboratoire d’Astrophysique de Bordeaux, 92–96, 2009.
- A. NEIDHARDT, M. ETTL, R. ZEITLHÖFLER, C. PLÖTZ, M. MÜHLBAUER, R. DASSING, H. HASE, S. SOBARZO, C. HERRERA, W. ALEF, H. ROTTMANN, E. HIMWICH: “A Concept for Remote Control of VLBI-telescopes and First Experiences at Wettzell”. In: Proceedings of the 19th European VLBI for Geodesy and Astrometry Working Meeting, edited by G. Bourda, P. Charlot, and A. Collioud, Université Bordeaux 1 – CNRS – Laboratoire d’Astrophysique de Bordeaux, 137–141, 2009.
- A. NEIDHARDT, G. KRONSNABL, R. SCHATZ: “Fundamentalstation Wettzell – 20m Radiotelescope”. In: International VLBI Service for Geodesy and Astrometry 2008 Annual Report, edited by D. Behrend and K. Baver, NASA/TP-2009-214183, 180–183, 2009.
- A. NIELL: “VLBI2010 Project for Geodesy and Astrometry”. In: Proceedings of the 19th European VLBI for Geodesy and Astrometry Working Meeting, edited by G. Bourda, P. Charlot, and A. Collioud, Université Bordeaux 1 – CNRS – Laboratoire d’Astrophysique de Bordeaux, 142–146, 2009.
- A. NIELL, A. WHITNEY: “Haystack Observatory Technology Development Center”. In: International VLBI Service for Geodesy and Astrometry 2008 Annual Report, edited by D. Behrend and K. Baver, NASA/TP-2009-214183, 321–324, 2009.
- T. NILSSON, J. DAVIS, E. HILL: “Using Ground-based GPS to Characterize Atmospheric Turbulence”. *Geophysical Research Letters*, 36, L16807, doi:10.1029/2009GL040090, 4 pp., 2009.
- T. NILSSON, R. HAAS: “An Assessment of Atmospheric Turbulence for CONT05 and CONT08”. In: Proceedings of the 19th European VLBI for Geodesy and Astrometry Working Meeting, edited by G. Bourda, P. Charlot, and A. Collioud, Université Bordeaux 1 – CNRS – Laboratoire d’Astrophysique de Bordeaux, 39–43, 2009.
- C. NOLL “CDDIS Data Center Summary for the 2008 IVS Annual Report”. In: International VLBI Service for Geodesy and Astrometry 2008 Annual Report, edited by D. Behrend and K. Baver, NASA/TP-2009-214183, 227–229, 2009.
- A. NOTHNAGEL: “Conventions on Thermal Expansion Modelling of Radio Telescopes for Geodetic and Astrometric VLBI.” *Journal of Geodesy*, 83(8), 787–792, 2009.
- A. NOTHNAGEL, S. BÖCKMANN, T. ARTZ: “Analysis Coordinator Report”. In: International VLBI Service for Geodesy and Astrometry 2008 Annual Report, edited by D. Behrend and K. Baver, NASA/TP-2009-214183, 80–82, 2009.
- A. NOTHNAGEL, A. MÜSKENS: “The Bonn Geodetic VLBI Operation Center”. In: International VLBI Service for Geodesy and Astrometry 2008 Annual Report, edited by D. Behrend and K. Baver, NASA/TP-2009-214183, 193–194, 2009.
- K. NOZAWA, H. SHIGEMATSU, K. KOKADO, S. KURIHARA: “Data Processing and Analysis Tools

- for Ultra-rapid UT1 Measurement”. IVS NICT Technology Development Center News, No. 30, ISSN 1882-3432, 33–35, October 2009.
- A. ORFEI, A. ORLATI, G. MACCAFERRI, F. MANTOVANI: “The Medicina Station Status Report”. In: International VLBI Service for Geodesy and Astrometry 2008 Annual Report, edited by D. Behrend and K. Baver, NASA/TP-2009-214183, 130–131, 2009.
- A. PANY, J. BÖHM, H. SCHUH, T. HOBIGER, R. ICHIKAWA: “Modeling Azimuthal Asymmetries of the Troposphere Delay during a 14-days Typhoon Period in Tsukuba”. In: Proceedings of the 19th European VLBI for Geodesy and Astrometry Working Meeting, edited by G. Bourda, P. Charlot, and A. Collioud, Université Bordeaux 1 – CNRS – Laboratoire d’Astrophysique de Bordeaux, 44–48, 2009.
- B. PETRACHENKO: “Canadian VLBI Technology Development Center”. In: International VLBI Service for Geodesy and Astrometry 2008 Annual Report, edited by D. Behrend and K. Baver, NASA/TP-2009-214183, 315–316, 2009.
- B. PETRACHENKO, A. NIELL, D. BEHREND, B. COREY, J. BÖHM, P. CHARLOT, A. COLLIOD, J. GIPSON, R. HAAS, T. HOBIGER, Y. KOYAMA, D. MACMILLAN, Z. MALKIN, T. NILSSON, A. PANY, G. TUCCARI, A. WHITNEY, J. WRESNIK: “Design Aspects of the VLBI2010 System – Progress Report of the IVS VLBI2010 Committee”. NASA/TM-2009-214180, 58 pp., 2009.
- B. PETRACHENKO, A. NIELL, D. BEHREND, B. COREY, J. BÖHM, P. CHARLOT, A. COLLIOD, J. GIPSON, R. HAAS, T. HOBIGER, Y. KOYAMA, D. MACMILLAN, Z. MALKIN, T. NILSSON, A. PANY, G. TUCCARI, A. WHITNEY, J. WRESNIK: “Design Aspects of the VLBI2010 System – Progress Report of the IVS VLBI2010 Committee”. In: International VLBI Service for Geodesy and Astrometry 2008 Annual Report, edited by D. Behrend and K. Baver, NASA/TP-2009-214183, 13–67, 2009.
- L. PETROV, C. PHILLIPS, A. BERTARINI, A. DELLER, S. POGREBENKO, A. MUJUNEN: “Use of the Long Baseline Array in Australia for Precise Geodesy and Absolute Astrometry.” Publications of the Astronomical Society of Australia, 26(1), 75–84, 2009.
- H.-P. PLAG, M. PEARLMAN (EDS.): “Global Geodetic Observing System: Meeting the Requirements of a Global Society on a Changing Planet in 2020”. Springer-Verlag Berlin Heidelberg, ISBN: 978-3-642-02686-7, 332 p., 2009.
- C. PLÖTZ, R. WOJZIAK, R. KILGER, A. NEIDHARDT: “German Antarctic Receiving Station (GARS) O’Higgins”. In: International VLBI Service for Geodesy and Astrometry 2008 Annual Report, edited by D. Behrend and K. Baver, NASA/TP-2009-214183, 142–145, 2009.
- M. POIRIER: “Westford Antenna”. In: International VLBI Service for Geodesy and Astrometry 2008 Annual Report, edited by D. Behrend and K. Baver, NASA/TP-2009-214183, 176–179, 2009.
- E. POPOVA: “Investigation of Systematic Variations of the Radio Source Coordinates using Position Time Series”. In: Proceedings of the All-Russian Astrometry Conference “Pulkovo-2009”, Izvestiya GAO, 219(4), St. Petersburg, 273–278, 2009. (in Russian)
- J. REDMOND, I. DIEGEL: “Goddard Geophysical and Astronomical Observatory”. In: International VLBI Service for Geodesy and Astrometry 2008 Annual Report, edited by D. Behrend and K. Baver, NASA/TP-2009-214183, 103–106, 2009.
- S. ROSAT, S. LAMBERT: “FCN Resonance Parameters from VLBI and Superconducting Gravimeter Data”. Astron. Astrophys., 503, 287–291, 2009.

- P. SARTI, C. ABBONDANZA, M. NEGUSINI: “Multi-technique Approach for Deriving a VLBI Signal Extra-path Variation Model Induced by Gravity: the Example of Medicina”. In: Proceedings of the 19th European VLBI for Geodesy and Astrometry Working Meeting, edited by G. Bourda, P. Charlot, and A. Collioud, Université Bordeaux 1 – CNRS – Laboratoire d’Astrophysique de Bordeaux, 35–38, 2009.
- P. SARTI, C. ABBONDANZA, L. VITTUARI: “Gravity-dependent Signal Path Variation in a Large VLBI Telescope Modelled with a Combination of Surveying Methods.” *Journal of Geodesy*, 83(11), 1115–1126, 2009.
- P. SARTI, L. VITTUARI, C. ABBONDANZA: “Laser Scanner and Terrestrial Surveying Applied to Gravitational Deformation Monitoring of Large VLBI Telescopes’ Primary Reflector.” *Journal of Surveying Engineering ASCE*, 135(4), 136–148, 2009.
- H. SCHUH, J. BÖHM, S. ENGLISH, R. HEINKELMANN, P.J. MENDES CERVEIRA, A. PANY, L. PLANK, H. SPICAKOVA, K. TEKE, J. WRESNIK: “Vienna IGG Special Analysis Center Annual Report 2008”. In: International VLBI Service for Geodesy and Astrometry 2008 Annual Report, edited by D. Behrend and K. Baver, NASA/TP-2009-214183, 273–276, 2009.
- W. SCHWEGMANN, M. GERSTL, R. HEINKELMANN: “BKG/DGFI Combination Center Annual Report 2008”. In: International VLBI Service for Geodesy and Astrometry 2008 Annual Report, edited by D. Behrend and K. Baver, NASA/TP-2009-214183, 250–252, 2009.
- M. SEITZ, H. DREWES, V. TESMER, R. HEINKELMANN: “DGFI Analysis Center Annual Report 2008”. In: International VLBI Service for Geodesy and Astrometry 2008 Annual Report, edited by D. Behrend and K. Baver, NASA/TP-2009-214183, 255–258, 2009.
- M. SEKIDO, M. KETTENIS, C. PHILLIPS, A. WHITNEY, Y. KOYAMA, H. HARAI: “Improvement of System Compatibility via eVLBI and VDIF (VLBI Data Interchange Format)”. *IVS NICT Technology Development Center News*, No. 30, ISSN 1882-3432, 13–16, October 2009.
- M. SEKIDO, M. KIMURA: “VLBI Correlators in Kashima”. In: International VLBI Service for Geodesy and Astrometry 2008 Annual Report, edited by D. Behrend and K. Baver, NASA/TP-2009-214183, 212–215, 2009.
- H. SHIGEMATSU, S. KURIHARA, K. KOKADO, K. NOZAWA: “Tsukuba VLBI Correlator”. In: International VLBI Service for Geodesy and Astrometry 2008 Annual Report, edited by D. Behrend and K. Baver, NASA/TP-2009-214183, 216–219, 2009.
- F. SHU, W. ZHENG, X. ZHANG, Z. XU, W. WANG, Z. CHEN: “Shanghai Correlation System Upgrade for Geodetic Application”. In: Proceedings of the 19th European VLBI for Geodesy and Astrometry Working Meeting, edited by G. Bourda, P. Charlot, and A. Collioud, Université Bordeaux 1 – CNRS – Laboratoire d’Astrophysique de Bordeaux, 87–91, 2009.
- E. SKURIKHINA, S. KURDUBOV, V. GUBANOV: “IAA VLBI Analysis Center Report 2008”. In: International VLBI Service for Geodesy and Astrometry 2008 Annual Report, edited by D. Behrend and K. Baver, NASA/TP-2009-214183, 269–272, 2009.
- S. SMOLENTSEV, I. RAHIMOV: “Svetloe Radio Astronomical Observatory”. In: International VLBI Service for Geodesy and Astrometry 2008 Annual Report, edited by D. Behrend and K. Baver, NASA/TP-2009-214183, 158–160, 2009.
- S. SMOLENTSEV, R. SERGEEV: “Badary Radio Astronomical Observatory”. In: International VLBI Service for Geodesy and Astrometry 2008 Annual Report, edited by D. Behrend and K. Baver, NASA/TP-2009-214183, 95–98, 2009.

- S. SOBARZO, E. OÑATE, C. JARA, C. HERRERA, P. ZAROR, C. DUGUET, M. SOTO, H. HASE, A. BÖER, B. SIERK: “Geodetic Observatory TIGO in Concepción”. In: International VLBI Service for Geodesy and Astrometry 2008 Annual Report, edited by D. Behrend and K. Baver, NASA/TP-2009-214183, 165–168, 2009.
- J. SOUCHAY, A. ANDREI, C. BARACHE, S. BOUQUILLON, A.-M. GONTIER, S. LAMBERT, C. LE PONCIN-LAFITTE, F. TARIS, E. ARIAS, D. SUCHET, M. BAUDIN: “The Construction of the Large Quasar Astrometric Catalogue (LQAC)”. *Astron. Astrophys.*, 494, 799–815, 2009.
- J. SOUCHAY, A. ANDREI, C. BARACHE, S. BOUQUILLON, A.-M. GONTIER, S. LAMBERT, C. LE PONCIN-LAFITTE, F. TARIS, E. ARIAS, D. SUCHET, M. BAUDIN: “The Large Quasar Astrometric Catalogue (LQAC): Principle of Compilation and Related Studies”. In: Proceedings of the “Journées 2008 Systèmes de référence spatio-temporels”, edited by M. Soffel and N. Capitaine, Lohrmann-Observatorium and Observatoire de Paris, 215, 2009.
- I. SURKIS, A. FATEEV, A. MELNIKOV, V. MISHIN, V. SHANTYR, V. ZIMOVSKY: “IAA Correlator Center”. In: International VLBI Service for Geodesy and Astrometry 2008 Annual Report, edited by D. Behrend and K. Baver, NASA/TP-2009-214183, 209–211, 2009.
- K. TAKEFUJI, R. ICHIKAWA, M. SEKIDO: “Technology Development Center at NICT”. In: International VLBI Service for Geodesy and Astrometry 2008 Annual Report, edited by D. Behrend and K. Baver, NASA/TP-2009-214183, 325–328, 2009.
- K. TAKEFUJI, Y. KOYAMA, H. TAKEUCHI: “First Fringe Detection with Next-Generation A/D Sampler ADS3000+”. *IVS NICT Technology Development Center News*, No. 30, ISSN 1882-3432, 17–21, October 2009.
- H. TAKIGUCHI, Y. KOYAMA: “The 8th NICT IVS-TDC Symposium”. *IVS NICT Technology Development Center News*, No. 30, ISSN 1882-3432, 1–2, October 2009.
- H. TAKIGUCHI, Y. KOYAMA, R. ICHIKAWA, T. GOTOH, A. ISHII, T. HOBIGER: “Comparison Study of VLBI and GPS Carrier Phase Frequency Transfer – Part II”. *IVS NICT Technology Development Center News*, No. 30, ISSN 1882-3432, 26–29, October 2009.
- D. TANIMOTO, S. KURIHARA, K. KOKADO, S. MATSUZAKA: “Tsukuba 32-m VLBI Station”. In: International VLBI Service for Geodesy and Astrometry 2008 Annual Report, edited by D. Behrend and K. Baver, NASA/TP-2009-214183, 169–172, 2009.
- E. TANIR, V. TORNATORE, K. TEKE: “Analyses on the Time Series of the Radio Telescope Coordinates of the IVS-R1 and -R4 Sessions”. In: Proceedings of the 19th European VLBI for Geodesy and Astrometry Working Meeting, edited by G. Bourda, P. Charlot, and A. Collioud, Université Bordeaux 1 – CNRS – Laboratoire d’Astrophysique de Bordeaux, 122–126, 2009.
- K. TEKE, J. BÖHM, H. SPICAKOVA, A. PANY, L. PLANK, H. SCHUH, E. TANIR: “Piecewise Linear Offsets for VLBI Parameter Estimation”. In: Proceedings of the 19th European VLBI for Geodesy and Astrometry Working Meeting, edited by G. Bourda, P. Charlot, and A. Collioud, Université Bordeaux 1 – CNRS – Laboratoire d’Astrophysique de Bordeaux, 63–67, 2009.
- K. TEKE, J. BÖHM, E. TANIR: “Clock Error and Tropospheric Delay Parameter Estimation Models of the Very Long Baseline Interferometry Technique”. *Journal of Mapping, General Command of Mapping (HGK)*, 142, 1–16, 2009. (in Turkish)
- V. TESMER, P. STEIGENBERGER, M. ROTHACHER, J. BÖHM, B. MEISEL: “Annual Deformation Signals from Homogeneously Reprocessed VLBI and GPS Height Time Series.” *Journal of Geodesy*, 83(10), 973–988, 2009.

- C. THOMAS, D. MACMILLAN: “CORE Operation Center Report”. In: International VLBI Service for Geodesy and Astrometry 2008 Annual Report, edited by D. Behrend and K. Bayer, NASA/TP-2009-214183, 195–197, 2009.
- V. THORANDT, A. NOTHNAGEL, G. ENGELHARDT, D. ULLRICH, T. ARTZ, S. BÖCKMANN: “The BKG/IGGB VLBI Analysis Center”. In: International VLBI Service for Geodesy and Astrometry 2008 Annual Report, edited by D. Behrend and K. Bayer, NASA/TP-2009-214183, 261–264, 2009.
- V. THORANDT, R. WOJZIAK: “BKG Data Center”. In: International VLBI Service for Geodesy and Astrometry 2008 Annual Report, edited by D. Behrend and K. Bayer, NASA/TP-2009-214183, 225–226, 2009.
- O. TITOV: “Geoscience Australia Analysis Center”. In: International VLBI Service for Geodesy and Astrometry 2008 Annual Report, edited by D. Behrend and K. Bayer, NASA/TP-2009-214183, 243–245, 2009.
- O. TITOV: “Systematic Effects in the Radio Source Proper Motion”. In: Proceedings of the 19th European VLBI for Geodesy and Astrometry Working Meeting, edited by G. Bourda, P. Charlot, and A. Collioud, Université Bordeaux 1 – CNRS – Laboratoire d’Astrophysique de Bordeaux, 14–18, 2009.
- O. TITOV, Z. MALKIN: “Effect of Asymmetry of the Radio Source Distribution on the Apparent Proper Motion Kinematic Analysis”. *Astron. Astrophys.*, 506(3), 1477–1485, 2009.
- M. TITUS, R. CAPPALLO, B. COREY, K. DUDEVOIR, A. NIELL, A. WHITNEY: “Haystack Observatory VLBI Correlator”. In: International VLBI Service for Geodesy and Astrometry 2008 Annual Report, edited by D. Behrend and K. Bayer, NASA/TP-2009-214183, 205–208, 2009.
- V. TORNATORE, R. HAAS: “Considerations on the Observation of GNSS-signals with the VLBI2010 System”. In: Proceedings of the 19th European VLBI for Geodesy and Astrometry Working Meeting, edited by G. Bourda, P. Charlot, and A. Collioud, Université Bordeaux 1 – CNRS – Laboratoire d’Astrophysique de Bordeaux, 151–155, 2009.
- G. TUCCARI: “Noto Station Status Report”. In: International VLBI Service for Geodesy and Astrometry 2008 Annual Report, edited by D. Behrend and K. Bayer, NASA/TP-2009-214183, 136–138, 2009.
- G. TUCCARI, S. BUTTACCIO, G. NICOTRA, W. ALEF, D. GRAHAM, A. ROY, M. WUNDERLICH, A. BERTARINI, A. NEIDHARDT, R. ZEITLHÖFLER: “DBBC.2 Backend System: Status Report”. In: Proceedings of the 19th European VLBI for Geodesy and Astrometry Working Meeting, edited by G. Bourda, P. Charlot, and A. Collioud, Université Bordeaux 1 – CNRS – Laboratoire d’Astrophysique de Bordeaux, 71–73, 2009.
- M. VENNEBUSCH, A. NOTHNAGEL, H. KUTTERER: “Singular Value Decomposition and Cluster Analysis as Regression Diagnostics Tools for Geodetic Applications.” *Journal of Geodesy*, 83(9), 877–891, 2009.
- V. VITYAZEV, D. TROFIMOV, M. KUDRYASHOVA: “Analysis Center of Saint Petersburg University”. In: International VLBI Service for Geodesy and Astrometry 2008 Annual Report, edited by D. Behrend and K. Bayer, NASA/TP-2009-214183, 241–242, 2009.
- A.E. VOLVACH: “Simeiz VLBI Station – H-maser and Mark 5B+ Upgrade”. In: International VLBI Service for Geodesy and Astrometry 2008 Annual Report, edited by D. Behrend and K.

- Baver, NASA/TP-2009-214183, 154–157, 2009.
- A. WHITNEY: “IVS Technology Coordinator Report”. In: International VLBI Service for Geodesy and Astrometry 2008 Annual Report, edited by D. Behrend and K. Baver, NASA/TP-2009-214183, 89–91, 2009.
- A. WHITNEY, M. KETTENIS, C. PHILLIPS, M. SEKIDO: “VLBI Data Interchange Format”. In: Proceedings of the 19th European VLBI for Geodesy and Astrometry Working Meeting, edited by G. Bourda, P. Charlot, and A. Collioud, Université Bordeaux 1 – CNRS – Laboratoire d’Astrophysique de Bordeaux, 156–160, 2009.
- A. WHITNEY, J. ROMNEY, K. OWENS: “The Mark 5C VLBI Data System”. In: Proceedings of the 19th European VLBI for Geodesy and Astrometry Working Meeting, edited by G. Bourda, P. Charlot, and A. Collioud, Université Bordeaux 1 – CNRS – Laboratoire d’Astrophysique de Bordeaux, 68–70, 2009.
- J. WRESNIK, J. BÖHM, A. PANY, H. SCHUH: “Towards a New VLBI System for Geodesy and Astrometry”. *Advances in Geosciences, Volume 13: Solid Earth (SE)*, 167–180 2009.
- J. WRESNIK, J. BÖHM, A. PANY, H. SCHUH: “VLBI2010 Simulations at IGG Vienna”. In: Proceedings of the 19th European VLBI for Geodesy and Astrometry Working Meeting, edited by G. Bourda, P. Charlot, and A. Collioud, Université Bordeaux 1 – CNRS – Laboratoire d’Astrophysique de Bordeaux, 147–150, 2009.
- J. WRESNIK, J. BÖHM, H. SCHUH: “VLBI2010 Simulation Studies.” In: *Geodetic Reference Frames*, edited by H. Drewes, IAG Symposia, 134, Springer-Verlag Berlin Heidelberg, 61–65, 2009.
- M. ZHANG, A. COLLIOD, P. CHARLOT: “A VLBI Image Model-Fitting Pipeline Programme”. In: Proceedings of the 19th European VLBI for Geodesy and Astrometry Working Meeting, edited by G. Bourda, P. Charlot, and A. Collioud, Université Bordeaux 1 – CNRS – Laboratoire d’Astrophysique de Bordeaux, 30–34, 2009.
- W. ZHENG, F. SHU, W. LUO, Y. YU, W. WANG: “Current Status of Chinese VLBI Network Software Correlator”. In: Proceedings of the 19th European VLBI for Geodesy and Astrometry Working Meeting, edited by G. Bourda, P. Charlot, and A. Collioud, Université Bordeaux 1 – CNRS – Laboratoire d’Astrophysique de Bordeaux, 84–86, 2009.



IVS Information

IVS Information





---

# IVS Terms of Reference

## 1. Summary

### 1.1. Charter

The International VLBI Service for Geodesy and Astrometry (IVS) is an international collaboration of organizations which operate or support Very Long Baseline Interferometry (VLBI) components. IVS provides a service which supports geodetic and astrometric work on reference systems, Earth science research, and operational activities.

IVS is an official Service of the International Association of Geodesy (IAG).

### 1.2. Objectives

IVS fulfills its charter through the following objectives. The primary objective of IVS is to foster VLBI programs as a joint service. This is accomplished through close coordination to provide high-quality VLBI data and products.

The second objective of IVS is to promote research and development activities in all aspects of the geodetic and astrometric VLBI technique. This objective also supports the integration of new components into IVS. The further education and training of VLBI participants is supported through workshops, reports, electronic network connections, and other means.

The third objective of IVS is to interact with the community of users of VLBI products and to integrate VLBI into a global Earth observing system. IVS interacts closely with the International Earth Rotation Service (IERS) which is tasked by the IAU and IUGG with maintaining the international celestial and terrestrial reference frames and with monitoring Earth rotation.

To meet these objectives, IVS coordinates VLBI observing programs, sets performance standards for VLBI stations, establishes conventions for VLBI data formats and data products, issues recommendations for VLBI data analysis software, sets standards for VLBI analysis documentation, and institutes appropriate VLBI product delivery methods to ensure suitable product quality and timeliness. IVS closely coordinates its activities with the astronomical community because of the dual use of many VLBI facilities and technologies for both astronomy and astrometry/geodesy.

IVS accepts observing proposals for research and operational programs that conform to the IVS objectives.

### 1.3. Data Products

VLBI data products contribute uniquely to these important determinations:

- definition and maintenance of the celestial reference frame
- monitoring universal time (UT1) and length of day (LOD)
- monitoring the coordinates of the celestial pole (nutations and precession)

These results are the foundation of many scientific and practical applications requiring the use of an accurate inertial reference frame, such as high-precision navigation and positioning. IVS provides, through the collaborative efforts of its components, a variety of significant VLBI data products with differing applications, timeliness, detail, and temporal resolution, such as:

- all components of Earth orientation parameters at regular intervals
- terrestrial reference frame
- VLBI data in appropriate formats
- VLBI results in appropriate formats
- local site ties to reference points
- high-accuracy station timing data
- surface meteorology, tropospheric and ionospheric measurements

All VLBI data products are archived in IVS Data Centers and are publicly available.

#### **1.4. Research**

The VLBI data products are used for research in many related areas of geodesy, geophysics, and astrometry, such as:

- UT1 and polar motion excitation (over periods of hours to decades)
- solid Earth interior research (mantle rheology, anelasticity, libration, core modes, nutation/precession)
- characterization of celestial reference frame sources and improvements to the frame
- tidal variations (solid Earth, oceanic, and atmospheric)
- improvements in the terrestrial reference frame, especially in the vertical (scale) component
- climate studies

To support these activities, there are ongoing research efforts whose purpose is to improve and extend the VLBI technique in such areas as:

- improvements in data acquisition and correlation
- refined data analysis techniques
- spacecraft tracking (Earth-orbiting and interplanetary)
- combination of VLBI data and results with other techniques

## **2. Permanent Components**

IVS acquires VLBI data, correlates the data, analyzes the data to produce geodetic, astrometric, and other results, and archives and publicizes data products. IVS accomplishes its goals through the types of permanent components described in this section. IVS will accept proposals at any time for a permanent component. Such proposals will be reviewed by the Directing Board. The seven types of IVS permanent components are:

- Network Stations
- Operation Centers
- Correlators

- Analysis Centers
- Data Centers
- Technology Development Centers
- Coordinating Center

IVS acquires VLBI data, correlates the data, analyzes the data to produce geodetic and astrometric results, and archives and publicizes data products. IVS accomplishes its goals through the operational components described below.

### **2.1. Network Stations**

The IVS observing network consists of high performance VLBI stations.

- Stations can be dedicated to geodesy or have multiple uses (including astronomical observations or satellite tracking applications).
- Stations comply with performance standards for data quality and operational reliability set up by the Directing Board.
- VLBI data acquisition sessions are conducted by groups of Network Stations that are distributed either globally or over a geographical region.

### **2.2. Operation Centers**

The IVS Operation Centers coordinate the routine operations of one or more networks. Operation Center activities include:

- planning network observing programs,
- establishing operating plans and procedures for the stations in the network,
- supporting the network stations in improving their performance,
- making correlator time available at an IVS Correlator,
- generating the detailed observing schedules for use in data acquisition sessions by IVS Network Stations,
- posting the observing schedule to an IVS Data Center for distribution and to the Coordinating Center for archiving.

IVS Operation Centers follow guidelines from the Coordinating Center for timeliness and schedule file formats. Operation Centers cooperate with the Coordinating Center in order to define:

- the annual master observing schedule,
- the use of antenna time,
- tape availability and shipping,
- the use of other community resources.

### 2.3. Correlators

The IVS Correlators process raw VLBI data and station log files following a data acquisition session. Their other tasks are to:

- provide immediate feedback to the Network Stations about problems that are apparent in the data,
- jointly maintain the geodetic/astrometric community's tape pool,
- make processed data available to the Analysis Centers,
- regularly compare processing techniques, models, and outputs to ensure that data from different Correlators are identical.

### 2.4. Analysis Centers

The IVS coordinates VLBI data analysis to provide high-quality products for its users. The analyses are performed by Operational Analysis Centers (hereinafter called Analysis Centers), Associate Analysis Centers, and Combination Centers.

Analysis Centers are committed to produce series of Earth Orientation Parameters (EOP) or series of individual EOP components, without interruption and at a specified time lag to meet IVS requirements. In addition, Analysis Centers produce station coordinates and source positions in regular intervals.

The Analysis Centers place their final results in IVS Data Centers for dissemination to researchers and other users. They adhere to IVS recommendations for the creation of high-quality products and their timely archiving and distribution. Any deviations that an Analysis Center makes from IVS recommendations are properly documented. Analysis Centers provide timely feedback about station performance. In addition to these regular services, Analysis Centers may also perform any task of an Associate Analysis Center.

Associate Analysis Centers are committed to regularly submit specialized products using complete series or subsets of VLBI observing sessions. The analysis is performed for specific purposes as recognized by the Directing Board such as exploitation of VLBI data for new types of results, investigations of regional phenomena, reference frame maintenance, or special determinations of Earth orientation parameters. The Associate Analysis Centers place their final results in IVS Data Centers for dissemination to researchers and other users. They adhere to IVS recommendations for the creation of high-quality products and their timely archiving and distribution. Any deviations that an Associate Analysis Center makes from IVS recommendations are properly documented.

Combination Centers are committed to quality control the submissions of the Analysis Centers to the IVS Data Centers and to produce combination results from the individual submissions as official IVS products. The products include, but are not limited to, EOP time series derived from session-based results for 24-hour network sessions and 1-hour Intensive sessions. The Combination Centers also contribute to the generation of the official IVS input to International Terrestrial Reference Frame (ITRF) computations. The combination work is done in a timely fashion and in close cooperation with the IVS Analysis Coordinator.

## 2.5. Data Centers

The IVS Data Centers are repositories for VLBI observing schedules, station log files, and data products. Data Centers may mirror other Data Centers to make the distribution and maintenance of data more efficient and reliable.

- Data Centers are the primary means of distributing VLBI products to users.
- Data Centers work closely with the Coordinating Center and with the Analysis Centers to ensure that all the information and data required by IVS components are quickly and reliably available.

Data Centers provide the following functions:

- receive and archive schedule files from Operation Centers,
- receive and archive log files and ancillary data files from the Network Stations,
- receive and archive data products from the Analysis Centers,
- provide access and public availability to IVS data products for all users.

## 2.6. Technology Development Centers

The IVS Technology Development Centers contribute to the development of new VLBI technology. They may be engaged in hardware and/or software technology development, or evolve new approaches that will improve the VLBI technique and enhance compatibility with different data acquisition terminals. They will:

- design new hardware,
- investigate new equipment,
- develop new software for operations, processing or analysis,
- generate new information systems,
- develop, test, and document prototypes of new equipment or software,
- assist with deployment, installation, and training for any new approved technology.
- After dissemination of the new hardware or software, the centers may continue to provide maintenance and updating functions.

## 2.7. Coordinating Center

The IVS Coordinating Center is responsible for coordination of both the day-to-day and the long-term activities of IVS, consistent with the directives and policies established by the Directing Board. Specifically, the Coordinating Center monitors, coordinates, and supports the activities of the Network Stations, Operation Centers, Correlators, Data Centers, Analysis Centers, and Technology Development Centers. The Coordinating Center works closely with the Technology Coordinator, the Network Coordinator, and the Analysis Coordinator to coordinate all IVS activities.

The primary functions of the Coordinating Center are to:

- coordinate observing programs approved by the Directing Board,

- maintain the master schedule of observing sessions, coordinating the schedule with astronomical observing programs and with IVS networks,
- foster communications among all components of the IVS,
- define the best use of community resources,
- develop standards for IVS components,
- provide training in VLBI techniques,
- organize workshops and meetings, including an annual IVS technical meeting,
- produce and publish reports of activities of IVS components,
- maintain the IVS information system and archive all documents, standards, specifications, manuals, reports, and publications,
- provide liaison with the IERS, IAG, IAU, and other organizations,
- provide the Secretariat of the Directing Board.

### **3. Coordinators**

Specific IVS activities for technology, network data quality, and data products are accomplished through the functions performed by three coordinators: a Network Coordinator, an Analysis Coordinator, and a Technology Coordinator.

#### **3.1. Network Coordinator**

The IVS Network Coordinator is selected by the Directing Board from responses to an open solicitation to all IVS components. The Network Coordinator represents the IVS Networks on the Directing Board and works closely with the Coordinating Center. The Network Coordinator is responsible for stimulating the maintenance of a high quality level in the station operation and data delivery. The Network Coordinator performs the following functions:

- monitors adherence to standards in the network operation,
- participates in the quality control of the data acquisition performance of the network stations,
- tracks data quality and data flow problems and suggests actions to improve the level of performance,

The Network Coordinator works closely with the geodetic and astronomical communities who are using the same network stations for observations. The Coordinator takes a leading role in ensuring the visibility and representation of the Networks.

#### **3.2. Analysis Coordinator**

The IVS Analysis Coordinator is selected by the Directing Board from responses to an open solicitation to the IVS Analysis Centers. The Analysis Coordinator is responsible for coordinating the analysis activities of IVS and for stimulating VLBI product development and delivery. The Analysis Coordinator performs the following functions:

- fosters comparisons of results from different VLBI analysis software packages and different analysis strategies,
- encourages analysis and combination software documentation,
- participates in comparisons of results from different space geodetic techniques,
- monitors Analysis Centers' products for high quality results and for adherence to IVS standards and IERS Conventions,
- ensures that analysis and combination products from all Analysis Centers are archived and available for the scientific community, and
- forms the official products of IVS, as decided by the IVS Directing Board, using a suitable combination of the analysis results submitted by the Analysis Centers.
- supervises the formation of the official IVS products, as decided by the IVS Directing Board, produced by the Combination Centers.

The Analysis Coordinator works closely with the geodetic and astronomical communities who are using some of the same analysis methods and software. The Analysis Coordinator plays a leadership role in the development of methods for distribution of VLBI products so that the products reach the widest possible base of users in a timely manner. The coordinator promotes the use of VLBI products to the broader scientific community and interacts with the IVS Coordinating Center and with the IERS.

### **3.3. Technology Coordinator**

The IVS Technology Coordinator is selected by the Directing Board from responses to an open solicitation to the IVS Technology Development Centers. The Technology Coordinator is responsible for coordinating the new technology activities of IVS and for stimulating advancement of the VLBI technique. The Technology Coordinator performs the following functions:

- maintains cognizance of all current VLBI technologies and ongoing development
- coordinates development of new technology among various IVS components
- helps promulgate new technologies to the geodetic/astrometric community
- strives to ensure the highest degree of global compatibility of VLBI data acquisition systems

The Technology Coordinator works closely with the astronomical community because of the many parallels between the technology development required for both groups.

## **4. Directing Board**

### **4.1. Roles and Responsibilities**

The Directing Board determines policies, adopts standards, and approves the scientific and operational goals for IVS. The Directing Board exercises general oversight of the activities of IVS including modifications to the organization that are deemed appropriate and necessary to maintain efficiency and reliability.

A specific function of the Board is to set scientific goals for the IVS observing program. The Board will establish procedures for external research programs and will review any proposals thus received.

The Board may determine appropriate actions to ensure the quality of the IVS products and that the IVS components maintain the adopted standards.

## 4.2. Membership

The Directing Board consists of appointed members who serve *ex officio*, members elected by the Directing Board, and members elected by the IVS components. The members are:

Appointed members *ex officio*:

- IAG representative
- IAU representative
- IERS representative
- Coordinating Center Director

Through a reciprocity agreement between IVS and IERS the IVS serves as the VLBI Technique Center for IERS, and as such its designated representative(s) serve on the IERS Directing Board. In turn, the IERS Directing Board designates a representative to the IVS Directing Board. This arrangement is to assure full cooperation between the two services.

Selected by Directing Board upon review of proposals from IVS Member Organizations:

- Technology, Network, and Analysis Coordinators (3 total)

Elected by Directing Board upon recommendation from the Coordinating Center (see below):

- Members at large (3)

Elected by IVS Components (see below):

- Correlators and Operation Centers representative (1)
- Analysis and Data Centers representative (1)
- Networks representatives (2)
- Technology Development Centers representative (1)

Total number: 15

The four appointed members are considered *ex officio* and are not subject to institutional restrictions.

The five members of the Directing Board who are elected by IVS Permanent Components must each be a member of a different IVS Member Organization. All elected members serve staggered four-year terms once renewable.

At large members are intended to ensure representation on the Directing Board of each of the components of IVS and to balance representation from as many countries and institutions and IVS interests as possible. At large members serve 2-year terms once renewable.

A Board member who departs before the end of his/her term is replaced by a person selected by the Directing Board. The new member will serve until the next official elections. The position will then be filled for a full term.



An individual can only serve two consecutive full terms on the Board in any of the representative and at large positions. Partial terms are not counted to this limit. After two consecutive full terms, the individual becomes eligible again for a position on the Board following a two-year absence.

The three Coordinators are selected by the Directing Board on the basis of proposals from IVS Member Organizations. On a two-thirds vote the Directing Board may call for new proposals for any Coordinator when it determines that a new Coordinator is required. Coordinators are encouraged to give at least three months notice before resigning.

### **4.3. Elections**

Election of Board members by the IVS components shall be conducted by a committee of three Directing Board members, the chair of which is appointed by the chair of the Directing Board. The committee solicits nominations for each representative from the relevant IVS components. For each position, the candidate who receives the largest number of votes from the Associate Members will be elected. In case of a tie the Directing Board will make the decision.

### **4.4. Chair**

The chair is one of the Directing Board members and is elected by the Board for a term of four years with the possibility of reelection for one additional term. The chair is the official representative of IVS to external organizations.

### **4.5. Decisions**

Most decisions by the Board are made by consensus or by simple majority vote of the members present. In case of a tie, the chair shall vote but otherwise does not vote. If a two-thirds quorum is not present, the vote shall be held later by electronic mail. A two-thirds vote of all Board members is required to modify the Terms of Reference, to change the chair, or to change any of the members elected by the Directing Board before the normal term expires.

### **4.6. Meetings**

The Board meets at least annually, or more frequently if meetings are called by the chair or at the request of at least three Board members. The Board will conduct periodic reviews of the IVS organization and its mandate, functions, and components. The reviews should be done every four years.

## **5. Definitions**

### **5.1. Member Organizations**

Organizations that support one or more IVS components are IVS Member Organizations. Individuals associated with IVS Member Organizations may become IVS Associate Members.

## 5.2. Affiliated Organizations

Organizations that cooperate with IVS on issues of common interest, but do not support an IVS component, are IVS Affiliated Organizations. Affiliated Organizations express an interest in establishing and maintaining a strong working association with IVS to mutual benefit. Individuals affiliated with IVS Affiliated Organizations may become IVS Correspondents.

## 5.3. Associate Members

Individuals associated with organizations that support an IVS component may become IVS Associate Members. Associate Members are generally invited to attend non-executive sessions of the Directing Board meetings with voice but without vote. Associate Members take part in the election of the incoming members of the Directing Board representing the IVS components.

## 5.4. Corresponding Members

IVS Corresponding Members are individuals on a mailing list maintained by the Coordinating Center. They do not actively participate in IVS but express interest in receiving IVS publications, wish to participate in workshops or scientific meetings organized by IVS, or generally are interested in IVS activities. Ex officio corresponding members are the following:

- IAG General Secretary
- President of IAG Commission 1 – Reference Frames
- President of IAG Commission 3 Geodynamics and Earth Rotation
- President of IAU Division I – Fundamental Astronomy
- President of IAU Commission 8 – Astrometry
- President of IAU Commission 19 – Rotation of the Earth
- President of IAU Commission 31 – Time
- President of IAU Commission 40 – Radio Astronomy
- President of URSI Commission J – Radio Astronomy

Individuals are accepted as IVS Corresponding Members upon request to the Coordinating Center.

Last modified: 12 February, 2010

## IVS Member Organizations

(alphabetized by country)

Organization	Country
Geoscience Australia	Australia
University of Tasmania	Australia
Vienna University of Technology	Austria
Centro de Rádio Astronomia e Aplicações Espaciais	Brazil
Geodetic Survey Division, Natural Resources Canada	Canada
Dominion Radio Astrophysical Observatory	Canada
Universidad de Concepción	Chile
Instituto Geográfico Militar	Chile
Chinese Academy of Sciences	China
Observatoire de Paris	France
Observatoire de Bordeaux	France
Deutsches Geodätisches Forschungsinstitut	Germany
Bundesamt für Kartographie und Geodäsie	Germany
Forschungseinrichtung Satellitengeodäsie, TU Munich	Germany
Institut für Geodäsie und Geoinformation der Universität Bonn	Germany
Max-Planck-Institut für Radioastronomie	Germany
Istituto di Radioastronomia INAF	Italy
Agenzia Spaziale Italiana	Italy
Geographical Survey Institute	Japan
National Institute of Information and Communications Technology	Japan
National Astronomical Observatory of Japan	Japan
National Institute of Polar Research	Japan
Auckland University of Technology	New Zealand
Norwegian Defence Research Establishment	Norway
Norwegian Mapping Authority	Norway
Astronomical Institute of St.-Petersburg University	Russia
Central (Pulkovo) Astronomical Observatory	Russia
Institute of Applied Astronomy	Russia
Sternberg State Astronomical Institute, Lomonosov Moscow State University	Russia
Hartebeesthoek Radio Astronomy Observatory	South Africa
Korea Astronomy and Space Science Institute	South Korea
Instituto Geográfico Nacional	Spain
Chalmers University of Technology	Sweden
Karadeniz Technical University	Turkey
Main Astronomical Observatory, National Academy of Sciences, Kiev	Ukraine
Laboratory of Radioastronomy of Crimean Astrophysical Observatory	Ukraine
NASA Goddard Space Flight Center	USA

Members

---

Organization	Country
U. S. Naval Observatory	USA
Jet Propulsion Laboratory	USA

---

## IVS Affiliated Organizations

Organization	Country
Australian National University	Australia
University of New Brunswick	Canada
Satellite Geodetic Observatory	Hungary
Joint Institute for VLBI in Europe (JIVE)	Netherlands
Westerbork Observatory	Netherlands
National Radio Astronomy Observatory	USA

## IVS Associate Members

Name	Institution	Country	E-mail
Alef, Walter	Max-Planck-Institut für Radioastronomie	Germany	walef@mpifr-bonn.mpg.de
Amagai, Jun	National Institute of Information and Communications Technology	Japan	amagai@nict.go.jp
Andersen, Per Helge	Norwegian Defence Research Establishment	Norway	per-helge.andersen@ffi.no
Andreeva, Tatiana	Institute of Applied Astronomy	Russia	ats@urania.rtf32s.nw.ru
Artz, Thomas	Institut für Geodäsie und Geoinformation der Universität Bonn	Germany	thomas.artz@uni-bonn.de
Bachmann, Sabine	Bundesamt für Kartographie und Geodäsie	Germany	sabine.bachmann@bkg.bund.de
Barache, Christophe	Observatoire de Paris	France	Christophe.Barache@obspm.fr
Baudry, Alain	Observatoire de Bordeaux	France	baudry@obs.u-bordeaux1.fr
Bauernfeind, Erhard	Fundamentalstation Wettzell	Germany	bauernfeind@fs.wettzell.de
Baver, Karen	NVI, Inc./GSFC	USA	karen.d.baver@nasa.gov
Behrend, Dirk	NVI, Inc./GSFC	USA	Dirk.Behrend@nasa.gov
Bellanger, Antoine	Observatoire de Bordeaux	France	bellanger@obs.u-bordeaux1.fr
Berdnikov, Anton	Institute of Applied Astronomy	Russia	
Bergman, Per	Onsala Space Observatory	Sweden	bergman@oso.chalmers.se
Bernhart, Simone	Institut für Geodäsie und Geoinformation der Universität Bonn	Germany	simone@mpifr-bonn.mpg.de
Bertarini, Alessandra	Institut für Geodäsie und Geoinformation der Universität Bonn	Germany	abertari@mpifr-bonn.mpg.de
Bérubé, Mario	Natural Resources Canada	Canada	mario@geod.nrcan.gc.ca
Bianco, Giuseppe	Agenzia Spaziale Italiana	Italy	bianco@asi.it
Bielmaier, Ewald	Fundamentalstation Wettzell	Germany	bielmaier@fs.wettzell.de
Boboltz, David	U. S. Naval Observatory	USA	dboboltz@usno.navy.mil
Böckmann, Sarah	Institut für Geodäsie und Geoinformation der Universität Bonn	Germany	boeckmann@uni-bonn.de
Böhm, Johannes	Institute of Geodesy and Geophysics	Austria	johannes.boehm@tuwien.ac.at

Name	Institution	Country	E-mail
Böhm, Sigrid	Institute of Geodesy and Geophysics	Austria	sigrid.boehm@tuwien.ac.at
Böer, Armin	BKG/Project TIGO	Chile	armin.boer@bkg.bund.de
Bolotin, Sergei	NVI, Inc./GSFC	USA	sergei.bolotin@nasa.gov
Booth, Roy	Hartebeesthoek RAO	South Africa	roy@hartrao.ac.za
Bougeard, Mireille	Observatoire de Paris	France	mireille.bougeard@obspm.fr
Bourda, Geraldine	Observatoire de Bordeaux	France	bourda@obs.u-bordeaux1.fr
Buttaccio, Salvo	Istituto di Radioastronomia INAF	Italy	s.buttaccio@ira.inaf.it
Cappallo, Roger	MIT Haystack Observatory	USA	rcappallo@haystack.mit.edu
Carlson, Brent	Dominion Radio Astrophysical Observatory	Canada	bcarlson@drao.nrc.ca
Carter, Merri Sue	U. S. Naval Observatory	USA	msc@nofs.navy.mil
Charlot, Patrick	Observatoire de Bordeaux	France	charlot@obs.u-bordeaux1.fr
Cho, Jung-ho	Korea Astronomy & Space Science Institute	South Korea	jojh@kasi.re.kr
Collioud, Arnaud	Observatoire de Bordeaux	France	collioud@obs.u-bordeaux1.fr
Colomer, Francisco	Instituto Geográfico Nacional	Spain	f.colomer@oan.es
Colucci, Giuseppe	Telespazio SpA	Italy	giuseppe.colucci@telespazio.com
Combrinck, Ludwig	Hartebeesthoek Radio Astronomy Observatory	South Africa	ludwig@bootes.hartrao.ac.za
Conway, John	Onsala Space Observatory	Sweden	jconway@chalmers.se
Corey, Brian	MIT Haystack Observatory	USA	bcorey@haystack.mit.edu
Curtis, Ronald	Honeywell TSI	USA	ronald.curtis@honeywell.com
Dassing, Reiner	Bundesamt für Kartographie und Geodäsie	Germany	reiner.dassing@bkg.bund.de
Del Rosso, Domenico	Telespazio SpA	Italy	domenico_delrosso@telespazio.it
de-Vicente, Pablo	Instituto Geográfico Nacional	Spain	p.devicente@oan.es
Diakov, Alexey	Institute of Applied Astronomy	Russia	ipazel@mail.svkchr.ru
Dickey, John	University of Tasmania	Australia	John.Dickey@utas.edu.au
Diegel, Irv	Honeywell TSI	USA	irv.diegel@honeywell-tsi.com
Doi, Koichiro	National Institute of Polar Research	Japan	doi@nipr.ac.jp
Dong, Yousuo	Urumqi Astronomical Observatory	China	dongys@ms.xjb.ac.cn

Name	Institution	Country	E-mail
Drewes, Hermann	Deutsches Geodätisches Forschungsinstitut	Germany	drewes@dgfi.badw.de
Dube, Maurice	SSAI/GSFC	USA	maurice.p.dube@nasa.gov
Elgered, Gunnar	Onsala Space Observatory	Sweden	kge@chalmers.se
Engelhardt, Gerald	Bundesamt für Kartographie und Geodäsie	Germany	gerald.engelhardt@bkg.bund.de
Engen, Bjørn	Norwegian Mapping Authority	Norway	bjorn.engen@statkart.no
Evangelista, Mark	Honeywell TSI	USA	mark.evangelista@honeywell-tsi.com
Fan, Qingyuan	Shanghai Astronomical Observatory	China	qyfan@center.shao.ac.cn
Fedotov, Leonid	Institute of Applied Astronomy	Russia	flv@ipa.nw.ru
Fey, Alan	U. S. Naval Observatory	USA	afey@usno.navy.mil
Finkelstein, Andrey	Institute of Applied Astronomy	Russia	amf@quasar.ipa.nw.ru
Fukuzaki, Yoshihiro	Geographical Survey Institute	Japan	fukuzaki@gsi.go.jp
Gambis, Daniel	Observatoire de Paris	France	daniel.gambis@obspm.fr
Gaume, Ralph	U. S. Naval Observatory	USA	rgaume@usno.navy.mil
Gipson, John	NVI, Inc./GSFC	USA	john.m.gipson@nasa.gov
Gomez, Frank	Raytheon/GSFC	USA	frank.g.gomez@nasa.gov
Gómez-González, Jesús	Instituto Geográfico Nacional	Spain	gomez@oan.es
Gontier, Anne-Marie	Observatoire de Paris	France	anne-marie.gontier@obspm.fr
Gordon, David	NVI, Inc./GSFC	USA	david.gordon-1@nasa.gov
Govind, Ramesh	Geoscience Australia	Australia	ramesh.govind@ga.gov.au
Gubanov, Vadim	Institute of Applied Astronomy	Russia	gubanov@quasar.ipa.nw.ru
Gulyaev, Sergei	Auckland University of Technology	New Zealand	sergei.gulyaev@aut.ac.nz
Haas, Rüdiger	Onsala Space Observatory	Sweden	rudiger.haas@chalmers.se
Hall, David	U. S. Naval Observatory	USA	dhall@usno.navy.mil
Hammargren, Roger	Onsala Space Observatory	Sweden	rogham@chalmers.se
Hanssen, Rune	Norwegian Mapping Authority	Norway	rune.hanssen@statkart.no
Harms, Matt	Honeywell TSI	USA	kokee@pele.kpgo.hawaii.edu
Hase, Hayo	BKG/Project TIGO	Chile	hayo.hase@bkg.bund.de
Heinkelmann, Robert	Deutsches Geodätisches Forschungsinstitut	Germany	heinkelmann@dgfi.badw.de
Helldner, Leif	Onsala Space Observatory	Sweden	helldner@chalmers.se
Herrera, Cristian	TIGO/Universidad de Concepción	Chile	cristian.herrera@tigo.cl



Name	Institution	Country	E-mail
Himwich, Ed	NVI, Inc./GSFC	USA	Ed.Himwich@nasa.gov
Hirabaru, Masaki	National Institute of Information and Communications Technology	Japan	masaki@nict.go.jp
Hobiger, Thomas	National Institute of Information and Communications Technology	Japan	hobiger@nict.go.jp
Hong, Xiaoyu	Shanghai Astronomical Observatory	China	xhong@center.shao.ac.cn
Honma, Mareki	National Astronomical Observatory of Japan	Japan	honmamr@cc.nao.ac.jp
Huang, Xinyong	Shanghai Astronomical Observatory	China	xhuang@center.shao.ac.cn
Hugentobler, Urs	Fundamentalstation Wettzell	Germany	urs.hugentobler@bv.tu-muenchen.de
Ichikawa, Ryuichi	National Institute of Information and Communications Technology	Japan	richi@nict.go.jp
Ihde, Johannes	Bundesamt für Kartographie und Geodäsie	Germany	johannes.ihde@bkg.bund.de
Ilijin, Gennadiy	Institute of Applied Astronomy	Russia	
Ipatov, Alexander	Institute of Applied Astronomy	Russia	ipatov@ipa.rssi.ru
Ipatova, Irina	Institute of Applied Astronomy	Russia	ipatova@isida.ipa.rssi.ru
Ishii, Atsutoshi	National Institute of Information and Communications Technology	Japan	ishii@nict.go.jp
Ivanov, D.V.	Institute of Applied Astronomy	Russia	
Jacobs, Chris	Jet Propulsion Laboratory	USA	chris.jacobs@jpl.nasa.gov
Jara, Cristobal	TIGO/Universidad de Concepción	Chile	cristobal.jara@tigo.cl
Jike, Takaaki	National Astronomical Observatory of Japan	Japan	jike@miz.nao.ac.jp
Johansson, Jan	Onsala Space Observatory	Sweden	jmj@chalmers.se
Johansson, Karl-Åke	Onsala Space Observatory	Sweden	karlake@chalmers.se
Johnson, Heidi	MIT Haystack Observatory	USA	hjohnson@haystack.mit.edu
Johnston, Kenneth	U. S. Naval Observatory	USA	kjj@astro.usno.navy.mil
Kaufmann, Pierre	Centro de Radio Astronomia e Aplicações Espaciais	Brazil	kaufmann@usp.br
Kawaguchi, Noriyuki	National Astronomical Observatory of Japan	Japan	kawagu.nori@nao.ac.jp
Kawai, Eiji	National Institute of Information and Communications Technology	Japan	kawa@nict.go.jp
Kaydanovsky, Michael	Institute of Applied Astronomy	Russia	kmn@isida.ipa.rssi.ru
Kharinov, Mikhail	Institute of Applied Astronomy	Russia	kharinov@ipa.rssi.ru

Name	Institution	Country	E-mail
Kimura, Moritaka	National Institute of Information and Communications Technology	Japan	mkimura@nict.go.jp
Kingham, Kerry	U. S. Naval Observatory	USA	kak@cygx3.usno.navy.mil
Kobayashi, Hideyuki	National Astronomical Observatory of Japan	Japan	hideyuki.kobayashi@nao.ac.jp
Kokado, Kensuke	Geographical Survey Institute	Japan	vlbi@gsi.go.jp
Kondo, Tetsuro	National Institute of Information and Communications Technology	Japan	kondo@nict.go.jp
Korkin, Edward	Institute of Applied Astronomy	Russia	korkin@isida.ipa.rssi.ru
Koyama, Yasuhiro	National Institute of Information and Communications Technology	Japan	koyama@nict.go.jp
Krasinsky, George	Institute of Applied Astronomy	Russia	kra@quasar.ipa.nw.ru
Kronshnabl, Gerhard	Bundesamt für Kartographie und Geodäsie	Germany	gerhard.kronshnabl@bkg.bund.de
Kuboki, Hiromitsu	National Institute of Information and Communications Technology	Japan	kuboki@nict.go.jp
Kudryashova, Maria	Astronomical Institute of St.-Petersburg	Russia	kudryashova@mercury.astro.spbu.ru
Kurdubov, Sergey	Institute of Applied Astronomy	Russia	ksl@quasar.ipa.nw.ru
Kurihara, Shinobu	Geographical Survey Institute	Japan	skuri@gsi.go.jp
Labelle, Ruth	SSAI/GSFC	USA	ruth.e.labelle@nasa.gov
Lambert, Sebastien	Observatoire de Paris	France	sebastien.lambert@obspm.fr
Langkaas, Line	Norwegian Mapping Authority	Norway	Line.Langkaas@statkart.no
Lanotte, Roberto	Telespazio SpA	Italy	lanotte@asi.it
Lauber, Pierre	Fundamentalstation Wettzell	Germany	lauber@fs.wettzell.de
Lavrov, Alexey	Institute of Applied Astronomy	Russia	
Le Bail, Karine	NVI, Inc./GSFC	USA	karine.lebail@nasa.gov
Li, Bing	Shanghai Astronomical Observatory	China	bing@center.shao.ac.cn
Li, Huihua	Shanghai Astronomical Observatory	China	hhl@center.shao.ac.cn
Li, Jinling	Shanghai Astronomical Observatory	China	jll@center.shao.ac.cn
Liang, Shiguang	Shanghai Astronomical Observatory	China	sgliang@center.shao.ac.cn
Lindqvist, Michael	Onsala Space Observatory	Sweden	Michael.Lindqvist@chalmers.se
Liu, Xiang	Urumqi Astronomical Observatory	China	liux@ms.xjb.ac.cn

Name	Institution	Country	E-mail
Long, Jim	NASA Goddard Space Flight Center	USA	jim.l.long@nasa.gov
Lonsdale, Colin	MIT Haystack Observatory	USA	clonsdale@haystack.mit.edu
Lovell, Jim	University of Tasmania	Australia	Jim.Lovell@utas.edu.au
Lowe, Stephen	Jet Propulsion Laboratory	USA	steve.lowe@jpl.nasa.gov
Lucena, Antonio	Centro de Radio Astronomia e Aplicações Espaciais	Brazil	macilio@roen.inpe.br
Luzum, Brian	U. S. Naval Observatory	USA	bjl@maia.usno.navy.mil
Ma, Chopo	NASA Goddard Space Flight Center	USA	chopo.ma-1@nasa.gov
Maccaferri, Giuseppe	Istituto di Radioastronomia INAF	Italy	g.maccaferri@ira.inaf.it
Machida, Morito	Geographical Survey Institute	Japan	machida@gsi.go.jp
MacMillan, Dan	NVI, Inc./GSFC	USA	daniel.s.macmillan@nasa.gov
Malkin, Zinovy	Pulkovo Observatory	Russia	malkin@gao.spb.ru
Manabe, Seiji	National Astronomical Observatory of Japan	Japan	manabe@miz.nao.ac.jp
Mantovani, Franco	Istituto di Radioastronomia INAF	Italy	f.mantovani@ira.inaf.it
Mardyshkin, Vyacheslav	Institute of Applied Astronomy	Russia	vvm@isida.ipa.rssi.ru
Marshalov, Dmitry	Institute of Applied Astronomy	Russia	
Mathiassen, Geir	Norwegian Mapping Authority	Norway	matgei@statkart.no
Matsuzaka, Shigeru	Geographical Survey Institute	Japan	shigeru@gsi.go.jp
McCarthy, Dennis	U. S. Naval Observatory	USA	dmc@maia.usno.navy.mil
Melnikov, Alexey	Institute of Applied Astronomy	Russia	melnikov@quasar.ipa.nw.ru
Michailov, Andrey	Institute of Applied Astronomy	Russia	agm@isida.ipa.rssi.ru
Miller, Natalia	Pulkovo Observatory	Russia	natmiller@list.ru
Mitchell, Donald	Honeywell TSI	USA	kokee@pele.kpgo.hawaii.edu
Müskens, Arno	Institut für Geodäsie und Geoinformation der Universität Bonn	Germany	mueskens@mpifr-bonn.mpg.de
Mukai, Yasuko	Geographical Survey Institute	Japan	mukai@gsi.go.jp
Nakajima, Junichi	National Institute of Information and Communications Technology	Japan	nakaji@nict.go.jp
Nanni, Mauro	Istituto di Radioastronomia INAF	Italy	m.nanni@ira.inaf.it

Name	Institution	Country	E-mail
Natusch, Tim	Auckland University of Technology	New Zealand	tim.natusch@aut.ac.nz
Negusini, Monia	Istituto di Radioastronomia INAF	Italy	m.negusini@ira.inaf.it
Neidhardt, Alexander	Fundamentalstation Wettzell	Germany	neidhardt@fs.wettzell.de
Nicolson, George	Hartebeesthoek Radio Astronomy Observatory	South Africa	george@bootes.hartrao.ac.za
Niell, Arthur	MIT Haystack Observatory	USA	aniell@haystack.mit.edu
Nielsen, Carl-Petter	Norwegian Mapping Authority	Norway	carl-petter.nielsen@statkart.no
Nikitin, Pavel	Crimean Astrophysical Observatory	Ukraine	nikitin@crao.crimea.ua
Nilsson, Tobias	Institute of Geodesy and Geophysics	Austria	tobias.nilsson@tuwien.ac.at
Noll, Carey	NASA Goddard Space Flight Center	USA	Carey.Noll@nasa.gov
Nothnagel, Axel	Institut für Geodäsie und Geoinformation der Universität Bonn	Germany	nothnagel@uni-bonn.de
Nozawa, Kentarou	Geographical Survey Institute	Japan	nozawa@gsi.go.jp
Ogaja, Clement	Geoscience Australia	Australia	Clement.Ogaja@ga.gov.au
Ojha, Roopesh	U. S. Naval Observatory	USA	rojha@usno.navy.mil
Olofsson, Hans	Onsala Space Observatory	Sweden	hans.olofsson@chalmers.se
Oñate, Eric	TIGO/Universidad del Bío Bío	Chile	eric.onate@tigo.cl
Orfei, Sandro	Istituto di Radioastronomia INAF	Italy	a.orfei@ira.inaf.it
Pany, Andrea	Institute of Geodesy and Geophysics	Austria	apany@mars.hg.tuwien.ac.at
Petrachenko, William	Natural Resources Canada	Canada	Bill.Petrachenko@nrc-cnrc.gc.ca
Pettersson, Lars	Onsala Space Observatory	Sweden	d8lars@chalmers.se
Plank, Lucia	Institute of Geodesy and Geophysics	Austria	lucia.plank@tuwien.ac.at
Plötz, Christian	Bundesamt für Kartographie und Geodäsie	Germany	christian.ploetz@bkg.bund.de
Poirier, Michael	MIT Haystack Observatory	USA	mpoirier@haystack.mit.edu
Popelar, Josef	Natural Resources Canada	Canada	popelar@geod.emr.ca
Qian, Zhihan	Shanghai Astronomical Observatory	China	qzh@center.shao.ac.cn
Quick, Jonathan	Hartebeesthoek Radio Astronomy Observatory	South Africa	jon@bootes.hartrao.ac.za
Rahimov, Ismail	Institute of Applied Astronomy	Russia	rahimov@urania.rtf32s.nw.ru
Redmond, Jay	Honeywell TSI	USA	jay.redmond@honeywell-tsi.com

Name	Institution	Country	E-mail
Reid, Brett	University of Tasmania	Australia	brett.reid@utas.edu.au
Richter, Bernd	Bundesamt für Kartographie und Geodäsie	Germany	bernd.richter@bkg.bund.de
Rioja, Maria	Instituto Geográfico Nacional	Spain	mj.rioja@oan.es
Ruszczyk, Chester	MIT Haystack Observatory	USA	chester@haystack.mit.edu
Salnikov, Alexander	Institute of Applied Astronomy	Russia	salnikov@isida.ipa.rssi.ru
Sarti, Pierguido	Istituto di Radioastronomia INAF	Italy	p.sarti@ira.inaf.it
Schatz, Raimund	Fundamentalstation Wettzell	Germany	schatz@fs.wettzell.de
Scherneck, Hans-Georg	Onsala Space Observatory	Sweden	hgs@chalmers.se
Schuh, Harald	Institute of Geodesy and Geophysics	Austria	harald.schuh@tuwien.ac.at
Schupler, Bruce	Honeywell TSI	USA	bruce.schupler@honeywell-tsi.com
Schwarz, Walter	Bundesamt für Kartographie und Geodäsie	Germany	walter.schwarz@bkg.bund.de
Sciarretta, Cecilia	Telespazio SpA	Italy	cecilia@asi.it
Searle, Anthony	Natural Resources Canada	Canada	asearle@NRCan.gc.ca
Seitz, Manuela	Deutsches Geodätisches Forschungsinstitut	Germany	seitz@dgfi.badw.de
Sekido, Mamoru	National Institute of Information and Communications Technology	Japan	sekido@nict.go.jp
Shao, Minghui	Urumqi Astronomical Observatory	China	nanshan@ms.xjb.ac.cn
Shibuya, Kazuo	National Institute of Polar Research	Japan	shibuya@nipr.ac.jp
Shigematsu, Hiromi	Geographical Survey Institute	Japan	vlbi@gsi.go.jp
Shishikin, Alexandr	Institute of Applied Astronomy	Russia	
Shu, Fengchun	Shanghai Astronomical Observatory	China	sfc@center.shao.ac.cn
Skurikhina, Elena	Institute of Applied Astronomy	Russia	sea@quasar.ipa.nw.ru
Smolentsev, Sergey	Institute of Applied Astronomy	Russia	smolen@isida.ipa.rssi.ru
Smythe, Dan	MIT Haystack Observatory	USA	dsmythe@haystack.mit.edu
Sobarzo, Sergio	TIGO/Universidad de Concepción	Chile	sergio.sobarzo@tigo.cl
Sokolova, Yulia	Pulkovo Observatory	Russia	s0lei@yandex.ru
Sousa, Don	MIT Haystack Observatory	USA	dsousa@haystack.mit.edu

Name	Institution	Country	E-mail
Sovers, Ojars	Remote Sensing Analysis Inc.	USA	ojars@rsasys.com
Spicakova, Hana	Institute of Geodesy and Geophysics	Austria	hana@mars.hg.tuwien.ac.at
Stanghellini, Carlo	Istituto di Radioastronomia INAF	Italy	c.stanghellini@ira.inaf.it
Steppe, Alan	Jet Propulsion Laboratory	USA	as@logos.jpl.nasa.gov
Surkis, Igor	Institute of Applied Astronomy	Russia	surkis@isida.ipa.rssi.ru
Takashima, Kazuhiro	Geographical Survey Institute	Japan	takasima@gsi.go.jp
Takiguchi, Hiroshi	National Institute of Information and Communications Technology	Japan	htaki@nict.go.jp
Tamura, Yoshiaki	National Astronomical Observatory of Japan	Japan	tamura@miz.nao.ac.jp
Tanimoto, Daisuke	Geographical Survey Institute	Japan	vlbi@gsi.go.jp
Tanir, Emine	Karadenic Technical University	Turkey	etanir@ktu.edu.tr
Tao, An	Shanghai Astronomical Observatory	China	antao@center.shao.ac.cn
Tateyama, Claudio	Centro de Radio Astronomia e Aplicações Espaciais	Brazil	tateyama@craam.mackenzie.br
Teke, Kamil	Institute of Geodesy and Geophysics	Austria	kteke@mars.hg.tuwien.ac.at
Thomas, Cynthia	NVI, Inc./GSFC	USA	cynthia.c.thomas@nasa.gov
Thorandt, Volkmar	Bundesamt für Kartographie und Geodäsie	Germany	volkmar.thorandt@bkg.bund.de
Thornton, Bruce	U. S. Naval Observatory	USA	blt@casa.usno.navy.mil
Titov, Oleg	Geoscience Australia	Australia	Oleg.Titov@ga.gov.au
Titus, Mike	MIT Haystack Observatory	USA	mtitus@haystack.mit.edu
Todorova, Sonja	Institute of Geodesy and Geophysics	Austria	stodo@mars.hg.tuwien.ac.at
Tomasi, Paolo	Istituto di Radioastronomia INAF	Italy	tomasi@ira.inaf.it
Trigilio, Corrado	Istituto di Radioastronomia INAF	Italy	ctrigilio@oact.inaf.it
Tsutsumi, Masanori	National Institute of Information and Communications Technology	Japan	tsutsumi@nict.go.jp
Tuccari, Gino	Istituto di Radioastronomia INAF	Italy	g.tuccari@ira.inaf.it
Ullrich, Dieter	Bundesamt für Kartographie und Geodäsie	Germany	dieter.ullrich@bkg.bund.de
Venturi, Tiziana	Istituto di Radioastronomia INAF	Italy	t.venturi@ira.inaf.it

Name	Institution	Country	E-mail
Vespe, Francesco	Agenzia Spaziale Italiana	Italy	vespe@asi.it
Vityazev, Veniamin	Astronomical Institute of St.-Petersburg	Russia	vityazev@list.ru
Volvach, Alexandr	Crimean Astrophysical Observatory	Ukraine	volvach@crao.crimea.ua
Vytnov, Alexander	Institute of Applied Astronomy	Russia	vytnov@isida.ipa.rssi.ru
Wang, Guangli	Shanghai Astronomical Observatory	China	wgl@center.shao.ac.cn
Wang, Jinqing	Shanghai Astronomical Observatory	China	jqwang@center.shao.ac.cn
Wang, Lingling	Shanghai Astronomical Observatory	China	llwang@center.shao.ac.cn
Wang, Na	Urumqi Astronomical Observatory	China	Na.wang@ms.xjb.ac.cn
Wang, Weixia	Urumqi Astronomical Observatory	China	wangwx@ms.xjb.ac.cn
Wei, Wenren	Shanghai Astronomical Observatory	China	wwr@center.shao.ac.cn
Whitney, Alan	MIT Haystack Observatory	USA	awhitney@haystack.mit.edu
Wojdziak, Reiner	Bundesamt für Kartographie und Geodäsie	Germany	reiner.wojdziaak@bkg.bund.de
Yatskiv, Yaroslav	Main Astronomical Observatory	Ukraine	yatskiv@mao.kiev.ua
Ye, Shuhua	Shanghai Astronomical Observatory	China	ysh@center.shao.ac.cn
Yusup, Aili	Urumqi Astronomical Observatory	China	aliyu@ms.xjb.ac.cn
Zeitlhöfler, Reinhard	Fundamentalstation Wettzell	Germany	zeitlhoefler@fs.wettzell.de
Zhang, Ali	Urumqi Astronomical Observatory	China	zhangal@uao.ac.cn
Zhang, Jin	Urumqi Astronomical Observatory	China	zhangj@ms.xjb.ac.cn
Zhang, Xiuzhong	Shanghai Astronomical Observatory	China	xzhang@shao.ac.cn
Zhao, Rongbing	Shanghai Astronomical Observatory	China	zhaorb@center.shao.ac.cn
Zheng, Weimin	Shanghai Astronomical Observatory	China	zhwm@shao.ac.cn
Zhou, Ruixian	Shanghai Astronomical Observatory	China	zrx@center.shao.ac.cn

## IVS Permanent Components

(listed by types, within types alphabetical by component name)

### Network Stations

<b>Component Name</b>	<b>Sponsoring Organization</b>	<b>Country</b>
Radioastronomical Observatory Badary	Institute of Applied Astronomy RAS	Russia
Fortaleza, Radio Observatório Espacial do Nordeste (ROEN)	Centro de Rádio Astronomia e Aplicações Espaciais	Brazil
Goddard Geophysical and Astronomical Observatory	NASA Goddard Space Flight Center	USA
Hartebeesthoek Radio Astronomy Observatory	Foundation for Research and Development	South Africa
Hobart, Mt. Pleasant Radio Observatory	University of Tasmania	Australia
Kashima 34m	National Institute of Information and Communications Technology (NICT)	Japan
Key Stone Project Kashima 11m	National Institute of Information and Communications Technology (NICT)	Japan
Key Stone Project Koganei	National Institute of Information and Communications Technology (NICT)	Japan
Kokee Park Geophysical Observatory	National Earth Orientation Service (NEOS)	USA
Matera	Agenzia Spaziale Italiana (ASI)	Italy
Medicina	Istituto di Radioastronomia	Italy
Mizusawa 10m	National Astronomical Observatory of Japan (NAOJ)	Japan
Noto (Sicily)	Istituto di Radioastronomia	Italy
Ny-Ålesund Geodetic Observatory	Norwegian Mapping Authority	Norway
ERS/VLBI Station O'Higgins	Bundesamt für Kartographie und Geodäsie (BKG)	Germany
Onsala Space Observatory	Chalmers University of Technology	Sweden
Seshan	Joint Laboratory for Radio Astronomy (JLRA), CAS and Shanghai Observatory, CAS	China
Simeiz	Laboratory of Radioastronomy of Crimean Astrophysical Observatory	Ukraine
Svetloe Radio Astronomy Observatory	Institute of Applied Astronomy RAS	Russia
JARE Syowa Station	National Institute of Polar Research	Japan



Transportable Integrated Geodetic Observatory (TIGO)	Universidad de Concepción (UdeC), Instituto Geográfico Militar (IGM), Bundesamt für Kartographie und Geodäsie (BKG)	Germany, Chile
Tsukuba VLBI Station	Geographical Survey Institute	Japan
Nanshan VLBI Station	Chinese Academy of Sciences	China
Warkworth Observatory	Auckland University of Technology	New Zealand
Westford Antenna, Haystack Observatory	NASA Goddard Space Flight Center	USA
Fundamentalstation Wettzell	Bundesamt für Kartographie und Geodäsie (BKG) and Forschungseinrichtung Satellitengeodäsie der Technischen Universität München (FESG)	Germany
Observatorio Astronómico Nacional - Yebes	Instituto Geográfico Nacional	Spain
Radioastronomical Observatory Zelenchukskaya	Institute of Applied Astronomy RAS	Russia

### Operation Centers

Component Name	Sponsoring Organization	Country
Institut für Geodäsie und Geoinformation (IGGB)	Universität Bonn	Germany
CORE Operation Center	NASA Goddard Space Flight Center	USA
NEOS Operation Center	National Earth Orientation Service (NEOS)	USA

### Correlators

Component Name	Sponsoring Organization	Country
Astro/Geo Correlator at MPI	Bundesamt für Kartographie und Geodäsie, Institut für Geodäsie und Geoinformation der Universität Bonn, Max-Planck-Institut für Radioastronomie	Germany
MIT Haystack Correlator	NASA Goddard Space Flight Center	USA
Institute of Applied Astronomy Correlator	Institute of Applied Astronomy	Russia
National Institute of Information and Communications Technology (NICT)	National Institute of Information and Communications Technology (NICT)	Japan
Tsukuba VLBI Center	Geographical Survey Institute	Japan
Washington Correlator	National Earth Orientation Service (NEOS)	USA

### Data Centers

Component Name	Sponsoring Organization	Country
BKG, Leipzig	Bundesamt für Kartographie und Geodäsie	Germany
Crustal Dynamics Data Information System (CDDIS)	NASA Goddard Space Flight Center	USA
GeoDAF	Agenzia Spaziale Italiana (ASI)	Italy
Italy INAF	Istituto di Radioastronomia INAF	Italy
National Institute of Information and Communications Technology	National Institute of Information and Communications Technology	Japan
Observatoire de Paris	Observatoire de Paris	France

### Analysis Centers

Component Name	Sponsoring Organization	Country
Astronomical Institute of St.-Petersburg University	Astronomical Institute of St.-Petersburg University	Russia
Geoscience Australia	Geoscience Australia	Australia
BKG/DGFI Combination Center	Bundesamt für Kartographie und Geodäsie and Deutsches Geodätisches Forschungsinstitut	Germany
Observatoire de Bordeaux	Observatoire de Bordeaux	France
Centro di Geodesia Spaziale (CGS)	Agenzia Spaziale Italiana	Italy
DGFI	Deutsches Geodätisches Forschungsinstitut	Germany
Forsvarets forskningsinstitutt (FFI)	Norwegian Defence Research Establishment	Norway
IGGB-BKG Analysis Center	Institut für Geodäsie und Geoinformation der Universität Bonn and Bundesamt für Kartographie und Geodäsie	Germany
Goddard Space Flight Center	NASA Goddard Space Flight Center	USA
Haystack Observatory	Haystack Observatory and NASA Goddard Space Flight Center	USA
Institute of Applied Astronomy Analysis Center	Institute of Applied Astronomy	Russia
Institute of Geodesy and Geophysics (IGG)	Institute of Geodesy and Geophysics (IGG) of the University of Technology, Vienna	Austria
Italy INAF	Istituto di Radioastronomia INAF	Italy
Jet Propulsion Laboratory	Jet Propulsion Laboratory	USA
Karadeniz Technical University (KTU)	Karadeniz Technical University	Turkey

Korea Astronomy and Space Science Institute	Korea Astronomy and Space Science Institute	South Korea
Main Astronomical Observatory	Main Astronomical Observatory, National Academy of Sciences, Kiev	Ukraine
National Astronomical Observatory of Japan	National Astronomical Observatory of Japan	Japan
National Institute of Information and Communications Technology	National Institute of Information and Communications Technology	Japan
Observatoire de Paris	Observatoire de Paris	France
Onsala Space Observatory	Chalmers University of Technology	Sweden
Pulkovo Observatory	Pulkovo Observatory	Russia
Sternberg State Astronomical Institute	Lomonosov Moscow State University	Russia
Shanghai Observatory	Shanghai Observatory, Chinese Academy of Sciences	China
U. S. Naval Observatory Analysis Center	U. S. Naval Observatory	USA
U. S. Naval Observatory Analysis Center for Source Structure	U. S. Naval Observatory	USA

### Technology Development Centers

Component Name	Sponsoring Organization	Country
Canadian VLBI Technology Development Center	NRCan, DRAO	Canada
Forsvarets forskningsinstitutt (FFI)	Norwegian Defence Research Establishment	Norway
Goddard Space Flight Center	NASA Goddard Space Flight Center	USA
Haystack Observatory	Haystack Observatory and NASA Goddard Space Flight Center	USA
Institute of Applied Astronomy Technology Development Center	Institute of Applied Astronomy	Russia
National Institute of Information and Communications Technology	National Institute of Information and Communications Technology	Japan
Onsala Space Observatory	Chalmers University of Technology	Sweden

## Addresses of Institutions of Authors Contributing to this Report

(listed alphabetically by country)

Australia Telescope National Facility, CSIRO

PO Box 76  
Epping  
NSW 1710  
Australia  
<http://www.atnf.csiro.au>

Geoscience Australia

PO Box 378  
Canberra ACT  
2601  
Australia  
<http://ga.gov.au>

University of Tasmania

School of Mathematics and Physics  
University of Tasmania  
Private Bag 37  
Hobart 7001  
Australia  
<http://www.phys.utas.edu.au/physics>

Institute of Geodesy and Geophysics/Vienna University of Technology

Gusshausstrasse 27-29  
1040 Vienna  
Austria  
<http://www.hg.tuwien.ac.at>

CRAAM, Universidade Presbiteriana Mackenzie, São Paulo

CRAAM  
Instituto Presbiteriano Mackenzie  
Rua da Consolação 896  
01302-907 São Paulo  
SP  
Brazil  
<http://www.craam.mackenzie.br>

Instituto Nacional de Pesquisas Espaciais

Estrada do Fio 6000  
Bairro Tupuiú  
61760-000 Eusébio  
CE  
Brazil  
<http://www.roen.inpe.br>

Geodetic Survey Division, Natural Resources Canada  
615 Booth St.  
Ottawa  
Ontario  
Canada K1A 0E9  
<http://www.geod.nrcan.gc.ca>

Bundesamt für Kartographie und Geodäsie - TIGO  
Casilla 4036  
Correo 3  
Concepción  
Chile  
<http://www.bkg.bund.de>

Universidad de Concepción - TIGO  
Concepción  
Chile  
<http://www.udec.cl>

Shanghai Astronomical Observatory, Chinese Academy of Sciences  
80 Nandan Road  
Shanghai 200030  
China  
<http://www.shao.ac.cn/eng/>

Observatoire de Paris, SYRTE, CNRS/UMR8630  
61 avenue de l'Observatoire  
75014 Paris  
France  
<http://www.obspm.fr>

Bundesamt für Kartographie und Geodäsie (BKG)  
Richard-Strauss-Allee 11  
60598 Frankfurt am Main  
Germany  
<http://www.bkg.bund.de>

Deutsches Geodätisches Forschungsinstitut (DGFI)  
Alfons-Goppel-Strasse 11  
80539 München  
Germany  
<http://www.dgfi.badw.de>

Geodätisches Observatorium Wettzell  
Bundesamt für Kartographie und Geodäsie (BKG) and  
Forschungseinrichtung Satellitengeodäsie (FESG)  
Sackenrieder Str. 25.  
D-93444 Kötzing  
Germany  
<http://www.fs.wettzell.de>

Institut für Geodäsie und Geoinformation der Universität Bonn  
Nussallee 17  
D-53115 Bonn  
Germany  
<http://vlbi.geod.uni-bonn.de>

Max-Planck-Institute for Radioastronomy  
Auf dem Hügel 69  
53121 Bonn  
Germany  
<http://www.mpifr-bonn.mpg.de>

Agenzia Spaziale Italiana  
Centro di Geodesia Spaziale (CGS)  
Contrada Terlecchia  
75100 Matera  
Italy  
<http://www.asi.it/>

Istituto di Radioastronomia, Bologna  
Via P. Gobetti 101  
40129 Bologna  
Italy  
<http://www.ira.inaf.it>

Istituto di Radioastronomia, Medicina  
C.P. 14  
40060 Villafontana  
Bologna  
Italy  
<http://www.med.ira.inaf.it>

Istituto di Radioastronomia INAF, Stazione VLBI di Noto  
C.P. 161  
I-96017 Noto SR  
Italy  
<http://www.noto.ira.inaf.it>

Geographical Survey Institute, Japan  
Kitasato 1  
Tsukuba  
Ibaraki  
Japan  
<http://vlbd.gsi.go.jp/sokuchi/vlbi/en/>

Mizusawa VLBI Observatory, National Astronomical Observatory of Japan  
2-12 Hoshigaoka-cho  
Mizusawa-kuk  
Oshu-shi  
Iwateken  
023-0861  
Japan  
<http://www.miz.nao.ac.jp>

National Institute of Information and Communications Technology  
893-1 Hirai  
Kashima  
Ibaraki 314-08501  
Japan  
[http://www2.nict.go.jp/w/w114/stsi/index\\_e.html](http://www2.nict.go.jp/w/w114/stsi/index_e.html)

National Institute of Polar Research  
10-3  
Midori-cho  
Tachikawa-shi  
Tokyo 190-8518  
Japan  
<http://www.nipr.ac.jp/welcome.html>

Joint Institute for VLBI in Europe  
Postbus 2 7990 AA Dwingeloo  
Netherlands  
<http://www.jive.nl>

Institute for Radio Astronomy and Space Research, Auckland University of Technology  
Private Bag 92006  
Auckland 1142  
New Zealand  
<http://www.irasr.ac.nz>

Forsvarets forskningsinstitutt (FFI) (Norwegian Defence Research Establishment)  
FFI/E  
Box 25  
2007 Kjeller  
Norway  
<http://www.ffi.no>

Geodetic Institute, Norwegian Mapping Authority  
Kartverksveien  
Hønefoss  
Norway  
<http://www.statkart.no>

Central Astronomical Observatory at Pulkovo of Russian Academy of Sciences

Pulkovskoe Ch. 65/1  
St. Petersburg  
196140  
Russia  
<http://www.gao.spb.ru>

Institute of Applied Astronomy of Russian Academy of Sciences (IAA)

nab. Kutuzova 10  
St. Petersburg  
191187  
Russia  
<http://www.ipa.nw.ru>

Sobolev Astronomical Institute of Saint Petersburg University

Universitetskii pr. 28  
Starii Peterhof  
Saint Petersburg  
198504  
Russia  
<http://www.astro.spbu.ru>

Sternberg State Astronomical Institute (SAI) of Moscow State University

Universitetskij prospekt 13  
Moscow  
119991  
Russia  
<http://www.sai.msu.ru>

HartRAO, NRF

PO Box 443  
Krugersdorp  
1740  
South Africa  
<http://www.hartrao.ac.za>

Ajou University

442-743  
South Korea  
<http://www.ajou.ac.kr>

Korea Astronomy and Space Science Institute

305-348  
South Korea  
<http://www.kasi.re.kr>

Instituto Geográfico Nacional

Calle General Ibañez de Ibero 3  
E-28003 Madrid  
Spain  
<http://www.ign.es/>



Observatorio Astronómico Nacional  
Calle Alfonso XII 3  
E-28014 Madrid  
Spain  
<http://www.oan.es/>

Onsala Space Observatory (OSO)  
SE-439 92  
Onsala  
Sweden  
<http://www.oso.chalmers.se>

Karadeniz Technical University, Department of Geomatics Engineering  
Trabzon  
61080  
Turkey  
<http://www.harita.ktu.edu.tr>

Main Astronomical Observatory, National Academy of Sciences of Ukraine  
Main Astronomical Observatory  
27 Akademika Zabolotnoho St.  
Kiev  
03680  
Ukraine  
<http://www.mao.kiev.ua>

Radio Astronomy Lab of Crimean Astrophysical Observatory  
RT-22  
Katsively  
Yalta Crimea 98688  
Ukraine  
<http://www.crao.crimea.ua>

Jet Propulsion Laboratory, California Institute of Technology  
Mail Stop 238-600  
4800 Oak Grove Dr.  
Pasadena CA 91109  
USA  
<http://www.jpl.nasa.gov>

Kokee Park Geophysical Observatory  
Kokee State Park  
P.O. Box 538  
Waimea, Hawaii 96796  
USA

## Contributing Institutions

---

### MIT Haystack Observatory

Off Route 40

Westford MA 01886

USA

<http://www.haystack.edu>

### NASA Goddard Space Flight Center

Code 698

Greenbelt, MD 20771

USA

<http://www.nasa.gov>

### United States Naval Observatory

3450 Massachusetts Avenue NW

Washington, DC 20392

USA

<http://www.usno.navy.mil/>

### United States Naval Observatory, Flagstaff Station

10391 West Naval Observatory Rd.

Flagstaff, AZ 86001

USA

<http://www.nofs.navy.mil/>

---

## List of Acronyms

AAS	American Astronomical Society
ABBC	Analog Base Band Converter
AC	(IVS) Analysis Center
ACF	AutoCorrelation Function
ACU	Antenna Control Unit
ADB	Analog to Digital Board
AES	Advanced Engineering Services Co., Ltd (Japan)
AGN	Active Galactic Nuclei
AGU	American Geophysical Union
AO	Astronomical Object
APEX	Atacama Pathfinder EXperiment
APSG	Asia-Pacific Space Geodynamics program
APT	Asia Pacific Telescope
ASI	Agenzia Spaziale Italiana (Italy)
ATM	Asynchronous Transfer Mode
ATNF	Australia Telescope National Facility (Australia)
AUT	Auckland University of Technology (New Zealand)
BADW	Bavarian Academy of Sciences (Germany)
BBC	Base Band Converter
BBD	Broadband Delay
BIPM	Bureau International des Poids et Mesures (France)
BKG	Bundesamt für Kartographie und Geodäsie (Germany)
BPE	Bernese Processing Engine
BSBH	Binary Systems of supermassive Black Holes
BVID	Bordeaux VLBI Image Database
BWG	Beam WaveGuide
BdRAO	Badary Radio Astronomical Observatory (Russia)
CARAVAN	Compact Antenna of Radio Astronomy for VLBI Adapted Network (Japan)
CAS	Chinese Academy of Sciences (China)
CAY	Centro Astronómico de Yebes (Spain)
CC	(IVS) Coordinating Center
CDAS	Chinese Digital Data Acquisition System (China)
CDDIS	Crustal Dynamics Data Information System (USA)
CDP	Crustal Dynamics Project
CDS	Centre de Données astronomiques de Strasbourg (France)
CE	Conformité Européene
CGS	Council for GeoScience (South Africa)
CGS	Centro di Geodesia Spaziale (Italy)
CIB	Correlator Interface Board
CNES	Centre National d'Etudes Spatiales (France)
CNIG	Centro Nacional de Información Geográfica (Spain)
CNRS	Centre National de la Recherche Scientifique (France)

CNS	Communication, Navigation and Surveillance systems, Inc. (USA)
CODA	Correlator Output Data Analyzer
CORE	Continuous Observations of the Rotation of the Earth
CORS	Continuously Operating Reference Stations
COSMIC	Constellation Observing System for Meteorology, Ionosphere and Climate
COSMO-SkyMed	COntellation of small Satellites for the Mediterranean basin Observation
CP	Circularly Polarized
CRAAE	Centro de Rádio Astronomia e Aplicações Espaciais (Brazil)
CRAAM	Centro de Rádio Astronomia e Astrofísica Mackenzie (Brazil)
CRESTech	Centre for Research in Earth and Space Technology (Canada)
CRF	Celestial Reference Frame
CRL	Communications Research Laboratory (now NICT) (Japan)
CSA	Canadian Space Agency (Canada)
CSIR	Council for Scientific and Industrial Research (South Africa)
CSIRO	Commonwealth Scientific and Industrial Research Organization (Australia)
CTI	Communication Techniques, Inc. (USA)
CVN	Chinese VLBI Network
CrAO	Crimean Astrophysical Observatory (Ukraine)
DAR	Data Acquisition Rack
DAS	Data Acquisition System
DBBC	Digital Base Band Converter
DBE	Digital BackEnd
DFT	Discrete Fourier Transform
DGFI	Deutsches Geodätisches Forschungsinstitut (Germany)
DHC	de Havilland Canada (Canada)
DLR	Deutsches Zentrum für Luft- und Raumfahrt (German Aerospace Center)
DMTD	Dual Mixer Time Difference
DOM	Data Output Module
DOR	Differenced One-way Range
DORIS	Doppler Orbitography and Radiopositioning Integrated by Satellite
DR	Dichroic Reflector
DRAO	Dominion Radio Astrophysical Observatory (Canada)
DREN	Defense Research and Engineering Network
DSN	Deep Space Network
DSP	Digital Signal Processor
DSS	Deep Space Station
DST	Department of Science and Technology (South Africa)
DeltaDOR	Delta Differenced One-way Range
EDM	Electronic Distance Measurement
EGU	European Geosciences Union
EIRP	Effective Isotropic Radiated Power
ENVISAT	ENVironmental SATellite
EOP	Earth Orientation Parameters
ESA	European Space Agency

---

ETS-Lindgren	EMC Test Systems-Lindgren (USA)
EUREF	EUropean REference Frame
EVGA	European VLBI for Geodesy and Astrometry
EVLA	Expanded Very Large Array
EVN	European VLBI Network
EXPReS	Express Production Real-time e-VLBI Service
FCN	Free Core Nutation
FES2004	Finite Element Solution 2004
FESG	Forschungseinrichtung Satellitengeodäsie/Technical University of Munich (Germany)
FFI	Forsvarets ForskningsInstitutt (Norwegian Defence Research Establishment) (Norway)
FILA10G	FIRst LAst
FRFF	Future Radio Frequencies and Feeds
FS	Field System
FTP	File Transfer Protocol
FWF	Fonds zur Förderung der wissenschaftlichen Forschung (Austrian Science Fund)
GA	Geoscience Australia (Australia)
GAPE	Great Alaska and Pacific Experiment
GARNET	GSI Advanced Radiotelescope NETwork (Japan)
GARS	German Antarctic Receiving Station (Germany)
GEMD	Geospatial and Earth Monitoring Division (Australia)
GEX	Giga-bit series VLBI EXperiment
GFZ	GeoForschungsZentrum (Germany)
GGAO	Goddard Geophysical and Astronomical Observatory (USA)
GGOS	Global Geodetic Observing System
GGP	Global Geodynamics Project
GISTM	GPS Ionospheric Scintillation and TEC Monitor
GLONASS	GLOBAL NAVigation Satellite System (Russia)
GLORIA	GLOBAL Radio Interferometry Analysis
GNS Science	Geological and Nuclear Sciences Research Institute (New Zealand)
GNSS	Global Navigation Satellite Systems
GOCE	Gravity Field and Steady-State Ocean Circulation Explorer
GOW	Geodetic Observatory Wettzell
GPS	Global Positioning System
GRACE	Gravity Recovery and Climate Experiment
GRAF	German GPS REference network
GRGS	Groupe de Recherches de Géodésie Spatiale (France)
GSD	Geodetic Survey Division of Natural Resources Canada (Canada)
GSFC	Goddard Space Flight Center (USA)
GSI	Geographical Survey Institute (Japan)
GSOC	German Space Operations Center
GeoDAF	Geodetic Data Archiving Facility (Italy)
HEMT	High Electron Mobility Transistor
HMO	Hermanus Magnetic Observatory (South Africa)

HPBW	Half Power Beam Width
HTS	High Temperature Superconductor
HTSI	Honeywell Technology Solutions Incorporated (USA)
HartRAO	Hartebeesthoek Radio Astronomy Observatory (South Africa)
IAA	Institute of Applied Astronomy (Russia)
IAG	International Association of Geodesy
IAU	International Astronomical Union
ICRF	International Celestial Reference Frame
ICRS	International Celestial Reference System
IDS	International DORIS Service
IDV	Intra-Day Variability
IERS	International Earth Rotation and Reference Systems Service
IF	Intermediate Frequency
IGFN	Italian Space Agency GPS Fiducial Network (Italy)
IGG	Institute of Geodesy and Geophysics (Austria)
IGGB	Institut für Geodäsie und Geoinformation der Universität Bonn (Germany)
IGM	Instituto Geográfico Militar (Chile)
IGN	Instituto Geográfico Nacional (Spain)
IGS	International GNSS Service
ILRS	International Laser Ranging Service
INAF	Istituto Nazionale di Astrofisica (Italy)
INGV	Institute of Geophysics and Volcanology (Italy)
INPE	Instituto Nacional de Pesquisas Espaciais (Brazil)
IPAC	Infrared Processing and Analysis Center (USA)
IRA	Istituto di RadioAstronomia (Italy)
IRASR	Institute for Radio Astronomy and Space Research (New Zealand)
ITRF	International Terrestrial Reference Frame
ITRS	International Terrestrial Reference System
IUGG	International Union of Geodesy and Geophysics
IVS	International VLBI Service for Geodesy and Astrometry
IWV	Integrated Water Vapor
IYA	International Year of Astronomy
JADE	Japanese Dynamic Earth observation by VLBI
JARE	Japanese Antarctic Research Expedition (Japan)
JIVE	Joint Institute for VLBI in Europe
JLRA	Joint Laboratory for Radio Astronomy (China)
JPL	Jet Propulsion Laboratory (USA)
JoG	Journal of Geodesy
KARAT	KAshima RAy-tracing Tools (Japan)
KARATS	KAshima RAy-Tracing Service (Japan)
KAREN	Kiwi Advanced Research and Education Network (New Zealand)
KASI	Korea Astronomy and Space Science Institute (Korea)
KAT	Karoo Array Telescope (South Africa)
KPGO	Koike Park Geophysical Observatory (USA)
KSP	KeyStone Project (Japan)

---

KSRC	Kashima Space Research Center (Japan)
KTU	Karadeniz Technical University (Turkey)
KVG	Korea VLBI for Geodesy (Korea)
KVN	Korean VLBI Network
LAGEOS	LASer GEOdynamic Satellite
LBA	Long Baseline Array (Australia)
LBADR	Long Baseline Array Disk Recorder
LEO	Low Earth Orbit
LLR	Lunar Laser Ranging
LNA	Low Noise Amplifier
LO	Local Oscillator
LOD	Length Of Day
LQAC	Large Quasar Astrometric Catalog
LRS	Laser Ranging System
LSB	Lower Side Band
LSC	Least Squares Collocation
LSM	Least Squares Method
MAO	Main Astronomical Observatory (Ukraine)
MARBLE	Multiple Antenna Radio-interferometry for Baseline Length Evaluation
MCI	Monitor and Control Infrastructure
MIT	Massachusetts Institute of Technology (USA)
MITEQ	Microwave Information Transmission Equipment (USA)
MLRO	Matera Laser Ranging Observatory (Italy)
MOBLAS	MOBILE LASer
MPI	Max-Planck-Institute (Germany)
MPIfR	Max-Planck-Institute for Radioastronomy (Germany)
MPM	Millimetre-Wave Propagation Model
MTLRS	Modular Transportable Laser Ranging System
NAO	National Astronomical Observatories (China)
NAOJ	National Astronomical Observatory of Japan (Japan)
NASA	National Aeronautics and Space Administration (USA)
NCAR	National Center for Atmospheric Research (USA)
NCCS	New Control Computer System
NCEP	National Centers for Environmental Prediction (USA)
NCRIS	National Collaborative Research Infrastructure Strategy (Australia)
NEC	NEC Corporation (originally Nippon Electric Company, Limited) (Japan)
NED	NASA/IPAC Extragalactic Database
NEOS	National Earth Orientation Service (USA)
NGS	National Geodetic Survey (USA)
NGSLR	Next Generation Satellite Laser Ranging system
NICT	National Institute of Information and Communications Technology (Japan)
NIPR	National Institute of Polar Research (Japan)
NMA	Norwegian Mapping Authority (Norway)
NMF	Niell Mapping Function
NMW	Numerical Weather Models

NNR	No-Net-Rotation
NNT	No-Net-Translation
NOAA	National Oceanic and Atmospheric Administration (USA)
NOFS	U.S. Naval Observatory Flagstaff Station (USA)
NRAO	National Radio Astronomy Observatory (USA)
NRCan	Natural Resources Canada (Canada)
NVI	NVI, Inc. (USA)
NetCDF	Network Common Data Form
OAM	Observatorio Astronómico de Madrid (Spain)
OAN	Observatorio Astronómico Nacional (Spain)
OCA	Observatoire de la Côte d'Azur (France)
OCARS	Optical Characteristics of Astrometric Radio Sources
OPAR	Observatoire de Paris (France)
OPC	(IVS) Observing Program Committee
ORCA	Optical ReCeiver/splitter/Amplifier
OS	Operating System
OSO	Onsala Space Observatory (Sweden)
PARNASSUS	Processing Application in Reference to NICT's Advanced Set of Softwares Usable for Synchronization
PERSAC	Pulkovo EOP and Reference Systems Analysis Center (Russia)
PFB	Polyphase Filter Bank
PIVEX	Platform Independent VLBI EXchange format
PLDRO	Phase Locked Dielectric Resonator Oscillator
PLXO	Phase Locked Crystal Oscillator
POLARIS	POLar motion Analysis by Radio Interferometric Surveying
PSU	Power Supply Unit
QZSS	Quasi Zenith Satellite System (Japan)
RAEGE	Red Atlántica de Estaciones Geodinámicas y Espaciales
RAO	Radio Astronomical Observatory
RAS	Russian Academy of Sciences (Russia)
RDBE	Roach Digital Backend
RDV	Research and Development sessions using the VLBA
RFI	Radio Frequency Interference
ROACH	Reconfigurable Open Architecture Computing Hardware
ROEN	Rádio-Observatório Espacial do Nordeste (Brazil)
RRFID	Radio Reference Frame Image Database
RTCP	Real-Time Transport Control Protocol
RTNF	Radio Telescope National Facility (New Zealand)
RTP	Real-Time Transport Protocol
SAC	Satellite Application Centre (South Africa)
SAI	Sternberg State Astronomical Institute
SATA	Serial Advanced Technology Attachment
SDK	Software Development Kit
SEFD	System Equivalent Flux Density
SHAO	SHanghai Astronomical Observatory (China)



---

SINEX	Solution INdependent EXchange format
SKA	Square Kilometer Array
SLR	Satellite Laser Ranging
SMART	Small Missions for Advanced Research and Technology
SOSW	Satellite Observing System Wettzell (Germany)
SPEED	Short Period and Episodic Earth rotation Determination
SPU	Saint-Petersburg University (Russia)
SPV	Signal Path Variation
SPbU	Saint-Petersburg University (Russia)
SRIF	Square Root Information Filter
SRT	Sardinia Radio Telescope (Italy)
SRTM	Shuttle Radar Topography Mission
SSAI	Science Systems and Applications, Inc. (USA)
SST	Satellite to Satellite Tracking
STEREO	Solar TERrestrial RELations Observatory
SvRAO	Svetloe Radio Astronomical Observatory (Russia)
TAC	Totally Accurate Clock
TANAMI	Tracking Active galactic Nuclei with Australia Milliarcsecond Interferometry (Australia)
TAO	Telecommunications Advanced Organization (Japan)
TDC	(IVS) Technology Development Center
TEC	Total Electron Content
TEMPO	Time and Earth Motion Precision Observations
TIGO	Transportable Integrated Geodetic Observatory (Germany, Chile)
TLRS	Transportable Laser Ranging System
TRF	Terrestrial Reference Frame
TTW	TWIN-Telescope Wettzell (Germany)
TWSTFT	Two-Way Satellite Time and Frequency Transfer
TZD	Total Zenith Delay
TerraSAR-X	Terra Synthetic Aperture Radars X-band (Germany)
UDC	Up-Down Converter
UEN	Up East North
UNIS	University Centre in Svalbard (Norway)
URSI	Union Radio-Scientifique Internationale
USB	Upper Side Band
USNO	United States Naval Observatory (USA)
UT	Universal Time
UT1	Universal Time
UTAS	University of TASmania (Australia)
UTC	Coordinated Universal Time
VC	Video Converter
VCS	VLBA Calibrator Survey
VDIF	VLBI Data Interchange Format
VERA	VLBI Exploration of Radio Astrometry
VEX	VLBI EXchange format

VLBA	Very Long Baseline Array (USA)
VLBI	Very Long Baseline Interferometry
VMF	Vienna Mapping Functions
VO	Virtual Observatory
VSI	VLBI Standard Interface
VSI-H	VLBI Standard Interface Hardware
VSI-S	VLBI Standard Interface Software
VSOP	VLBI Space Observatory Program
VSSP	Versatile Scientific Sampling Processor
VTEC	Vertical Total Electron Content
VTP	VLBI Transmission Protocols
VTRF	VLBI Terrestrial Reference Frame
WACO	WAshington COrrrelator (USA)
WG	Working Group
WMAP	Wilkinson Microwave Anisotropy Probe
WVR	Water Vapor Radiometer
WWW	World Wide Web
XDM	eXperimental Development Model
ZHD	Zenith Hydrostatic Delay
ZTD	Zenith Total Delay
ZWD	Zenith Wet Delay
ZcRAO	Zelenchukskaya Radio Astronomical Observatory (Russia)
e-VLBI	Electronic VLBI







REPORT DOCUMENTATION PAGE			Form Approved OMB No. 0704-0188		
<p>The public reporting burden for this collection of information is estimated to average 1 hour per response, including the time for reviewing instructions, searching existing data sources, gathering and maintaining the data needed, and completing and reviewing the collection of information. Send comments regarding this burden estimate or any other aspect of this collection of information, including suggestions for reducing this burden, to Department of Defense, Washington Headquarters Services, Directorate for Information Operations and Reports (0704-0188), 1215 Jefferson Davis Highway, Suite 1204, Arlington, VA 22202-4302. Respondents should be aware that notwithstanding any other provision of law, no person shall be subject to any penalty for failing to comply with a collection of information if it does not display a currently valid OMB control number.</p> <p><b>PLEASE DO NOT RETURN YOUR FORM TO THE ABOVE ADDRESS.</b></p>					
1. REPORT DATE (DD-MM-YYYY) 27-08-2010		2. REPORT TYPE Technical Publication		3. DATES COVERED (From - To)	
4. TITLE AND SUBTITLE International VLBI Service for Geodesy and Astrometry 2009 Annual Report			5a. CONTRACT NUMBER		
			5b. GRANT NUMBER		
			5c. PROGRAM ELEMENT NUMBER		
6. AUTHOR(S) Dirk Behrend, Karen D. Baver			5d. PROJECT NUMBER		
			5e. TASK NUMBER		
			5f. WORK UNIT NUMBER		
7. PERFORMING ORGANIZATION NAME(S) AND ADDRESS(ES) Goddard Space Flight Center Greenbelt, MD 20771			8. PERFORMING ORGANIZATION REPORT NUMBER 2010-		
9. SPONSORING/MONITORING AGENCY NAME(S) AND ADDRESS(ES) National Aeronautics and Space Administration Washington, DC 20546-0001			10. SPONSORING/MONITOR'S ACRONYM(S)		
			11. SPONSORING/MONITORING REPORT NUMBER NASA/TP-2010-217: 82		
12. DISTRIBUTION/AVAILABILITY STATEMENT Unclassified-Unlimited, Subject Category: 46 Report available from the NASA Center for Aerospace Information, 7121 Standard Drive, Hanover, MD 21076. (301)621-0390					
13. SUPPLEMENTARY NOTES Dirk Behrend, NVI, Inc., Greenbelt, MD; Karen Baver, NVI, Inc., Greenbelt, MD					
14. ABSTRACT This volume of reports is the 2009 Annual Report of the International VLBI Service for Geodesy and Astrometry (IVS). The individual reports were contributed by VLBI groups in the international geodetic and astrometric community who constitute the components of IVS. The 2009 Annual Report documents the work of these IVS components over the period January 1, 2009 through December 31, 2009. The reports document changes, activities, and progress of the IVS. The entire contents of this Annual Report also appear on the IVS Web site at <a href="http://ivsec.gsfc.nasa.gov/publications/ar2009">http://ivsec.gsfc.nasa.gov/publications/ar2009</a> .					
15. SUBJECT TERMS Geodesy, astrometry, VLBI, geophysics, Earth orientation, very long baseline interferometry, interferometry, radio astronomy, geodynamics, reference frames, terrestrial reference frame, celestial reference frame, length of day, Earth system science, Earth rotation.					
16. SECURITY CLASSIFICATION OF:			17. LIMITATION OF ABSTRACT	18. NUMBER OF PAGES	19b. NAME OF RESPONSIBLE PERSON
a. REPORT	b. ABSTRACT	c. THIS PAGE			Dirk Behrend
Unclassified	Unclassified	Unclassified	Unclassified	368	19b. TELEPHONE NUMBER (Include area code) (301) 614-5939

Back cover: As an activity of the International Year of Astronomy 2009 the IVS observed the Very Large Astrometry Session IYA09. A network of initially 35 stations joined to participate in the largest 24-hour session ever undertaken (previous record 23 stations). Beyond the outreach activities, IYA09 had the goal of observing as many ICRF2 defining sources as possible (ultimately 243 out of the 295) and to provide the arc lengths between all sources without relying on source overlaps. The back cover shows the original observational network of the IYA09 session. More information can be found in the reports on pages 39ff and 213ff.

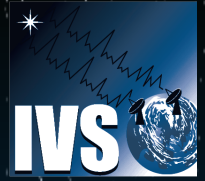

International VLBI Service for Geodesy and Astrometry

IVS Coordinating Center  
NASA Goddard Space Flight Center  
Code 698.2  
Greenbelt, MD 20771

<http://ivscg.gsfc.nasa.gov>  
[ivscg@ivscg.gsfc.nasa.gov](mailto:ivscg@ivscg.gsfc.nasa.gov)  
phone: 301-614-5939  
fax: 301-614-6522